

Module 4

Stereographic projection: concept and application

Lecture 4

Stereographic projection: concept and application

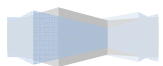

Keywords: definition, properties, poles & planes, great & small circle, Wulff net, measurement of the angle between two poles, rotation about any axis, standard projection of cubic crystal

Introduction

Stereographic projection provides a means of representing different planes and directions of a crystal in 2 dimensions. It allows measurement of angles between planes and directions. We are more familiar with engineering projection which is a distance true projection. This provides a sketch of a 3-dimensional object as it is viewed from three different angles. It consists of a plan, an elevation and a side view. The distance between two points on the object is linearly related to that in the projection. As against this stereographic projection is an angle true projection. The angular relation between different directions is maintained but not the linear distances. The following sketch highlights the major differences in the ways such projections are drawn. Engineering projection is taken with the help of a set parallel beam of rays whereas stereographic projection is taken with the help of a point source of light. In addition in engineering projection the object is real with exact dimension whereas in stereographic projection the object is assumed to be tiny. In fact it is so small that all planes within it could be assumed to be passing through the origin. This is why distance is of no significance. However the angles between directions remain the same. This is why it is often referred to as angle true projection.

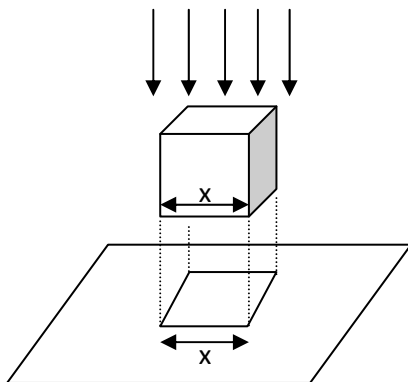

Figure 1: Normal engineering projection uses parallel beam of rays. This ensures correspondence between distances between two points.

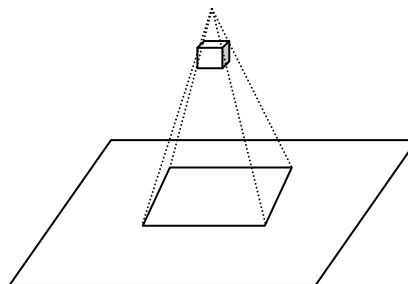

Figure 2: Projection with the help of a point source of light. Object gets magnified.

How is such a projection constructed?

Unlike engineering projection the object is hypothetical. It is dimensionless. The question that comes up is what do we project? There are hypothetical lines and planes passing through the origin denoting plane normal and planes. This section describes how a projection of these lines and planes could be constructed. Imagine that a tiny crystal placed at the centre of a large sphere called reference sphere as shown in figure 3. Any plane within the crystal if extended would intersect the reference sphere along a circle. A perpendicular to this plane passing through origin if extended would intersect the reference sphere at a pair of points called poles separated by 180° .



Figure 3: Imagine that a tiny crystal is placed at the centre of a large reference sphere. The crystal is so small that any plane you think of within the crystal would pass through the origin. If you extend the same it would intersect the sphere along a circle. Its radius would be the same as that of the sphere. Such circles are called great circles. Figure shows 3 such circles representing three cube planes. Note its similarity with that of a globe. This is why the poles are often denoted as east (E), west (W), north (N) & south (S).

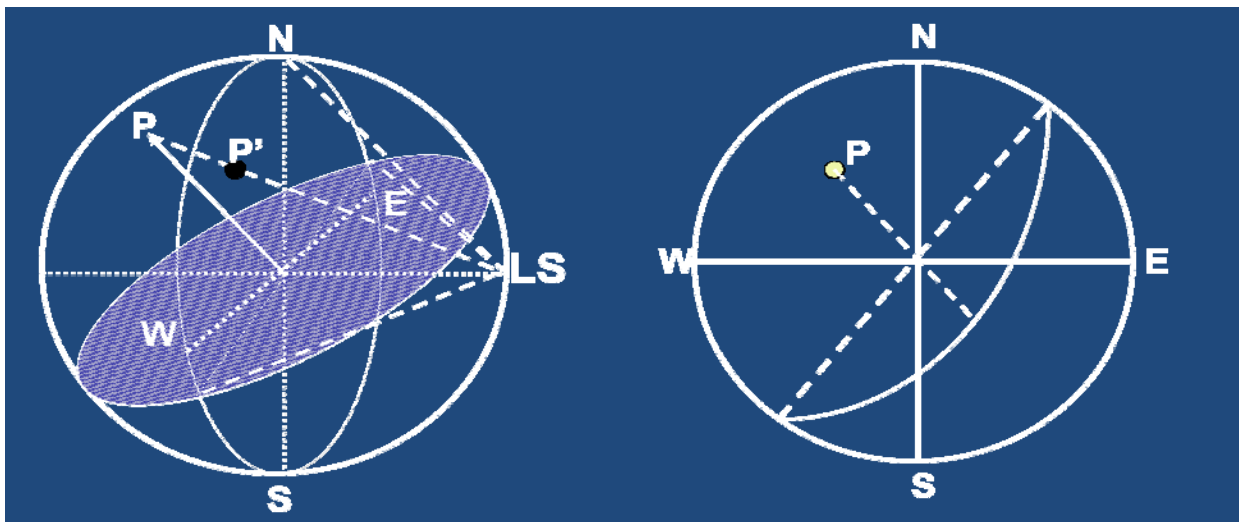

Figure 4: Shows a reference sphere with a tiny crystal at its centre. NS represents north & south poles as in a globe. EW likewise denote east west axis. The hatched surface represents a plane which has been extended to intersect the sphere along a great circle. The normal to this plane is extended to meet the spherical surface at point P called the pole of this plane. Assume the sphere to be transparent & the poles including the points N, S, E, W be marked as black dots. Place a light source at LS and project the poles (black dots) on the plane passing through N-S & E-W axes as shown. The point P' represents the location of the pole P in the stereographic projection of the crystal.

Figure 5: Represents a stereographic projection of the plane and the pole P of the crystal placed at the centre of a reference sphere as shown in figure 4. Here the point P' has been denoted as P. Note that the plane passing through poles N, W, S, E called projection plane appears as a circle whose radius is same as that of the reference sphere. The straight lines joining NS and EW are in reality great circles; a meridian passing through the NS axis of the sphere and its equatorial plane. The hatched surface in figure 4 meets the sphere along a great circle. Its projection appears as a curved line similar to that of a longitude on a globe. This too represents a great circle.

3

The above illustrations tell us how to represent a plane or a pole of a crystal on a stereographic projection. In any 2D sketch or drawing we need a set of reference axes and a co-ordinate system to

specify the location of any point or a set of points comprising a line or a curve. For example on a globe the location of a place is specified in terms of longitudes and latitudes. Longitude represents the intersection of a plane passing through the centre of the globe and North & South poles with that of the globe. It is an imaginary circle having the same radius as that of the globe. Latitude represents the intersection of a plane perpendicular to north south axes but not necessarily passing through the origin, with that of the globe surface. It is also an imaginary line on the surface of the globe. Its radius keeps increasing from zero at North Pole to its maximum at the equatorial plane and keeps decreasing there after till it becomes zero at South Pole. Imagine a ruled transparent globe consisting of longitudes and latitudes drawn at regular intervals. If you take its stereographic projection you would get a set of grid lines within a circle called Wulff net. A sample is shown in figure 6.

Wulff net & its applications

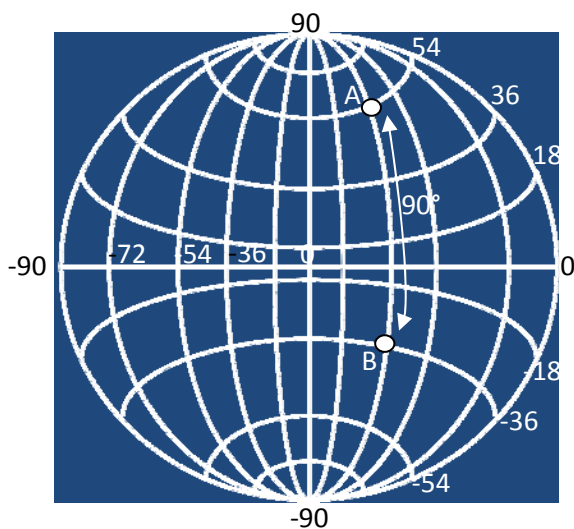

Figure 6: This is a schematic representation of what a Wulff net looks like. Note that the outer circle is also a longitude. Its centre coincides with that of the reference circle. The vertical straight line passing through North & South poles is also a longitude. Its centre lies at infinity. Rest of the longitudes have their centres lying on the equator between the centre of reference circle and infinity. Latitudes are lines not passing through North & South poles. Equator is also a latitude although it represents the projection of a great circle. Its centre lies on the line joining NS poles at infinity. Rest of the latitudes are also circles with their centres in between infinity & the centre of the reference circle on NS axis.

A pole is a point whose coordinates are described by its longitude and latitude. The Wulff net may be assumed to consist of four quadrants: NE, NW, SW and SE. As an illustration let us place a pole at 36°N 54°E and another at 36°S 36°E. Note that both the poles lie on same longitude. A pole you may recall denotes normal to a plane and a longitude in a Wulff net also denotes a plane. Since the two poles are on the same longitude it means that the perpendicular to the two planes lie on the same plane. Therefore the angle between the two can be directly read from the latitudes. In this case it comes to be 90°.

Wulff net also helps in performing rotation operation. Such an operation should not alter the relative positions of the poles of a crystal. There are two poles in a Wulff net about which rotation can easily be performed. These are the centre of the net and either of the two poles; north or south. The former is a simple rotation operation where as in case of the latter the latitudes are the paths about which the poles should move.

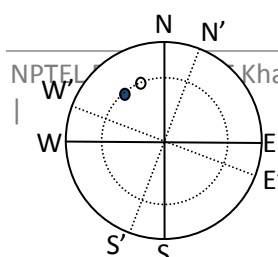

Figure 7: Illustrates rotation about the centre of the projection. Note that the locations of all poles except the one at the centre change. The dotted circle is the path the pole takes during rotation. Locations of new NS & EW axes are shown as dotted lines.

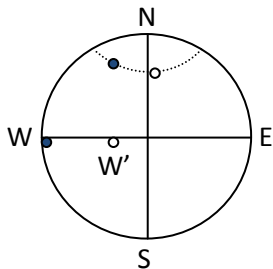

Figure 8: Illustrates rotation about either North or South poles. All poles except N & S move along respective latitudes. Filled in small circles represent positions before rotation and unfilled small circles denote positions after rotation. Note that the equator is also a small circle or latitude. It also can be considered as mirror plane. This is evident from the shapes of latitudes on either sides of the equator. Note that pole W also moves through the same angle. Its new

Angles between planes & poles

The angle between two planes and that between their normals are identical. Figure 9 - 10 illustrates the use of Wulff net in the measurement of angles between two poles. It is more convenient to represent poles rather than plane on a projection. A plane as already explained is represented by a great circle. It is often necessary to plot locations of at least three poles not lying on the same great circle to represent the orientation of a crystal. The projection gets crowded if we try to represent each plane by great circles.

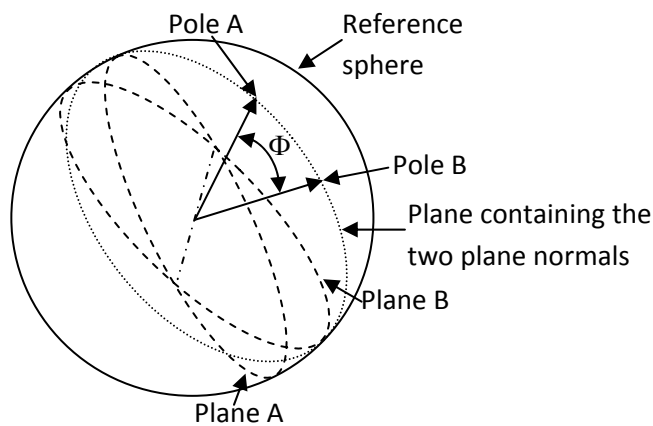

Figure 9: Shows location of two planes and their perpendiculars within a reference sphere. Plane containing the two plane normals is also displayed. Angle between the two should be measured by placing a protector on this plane.

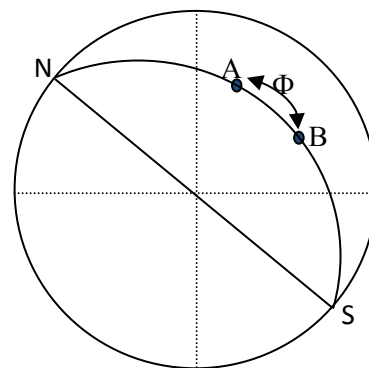

Figure 10: This is the stereographic projection displaying location of these two poles. To find out the angle between the two put a Wulff net on it. It is kept in such a way that the two poles lie on a longitude. The angle is obtained subtracting latitude of B from that of A.

How to locate a plane corresponding to a pole?

A pole represents a normal to a plane. It means that the angle between the pole and any line on the plane should be 90° . Therefore the plane on the projection should be the locus of a point subtending 90° with the pole. This can be drawn by placing the projection on a transparent sheet placed on the Wulff net such that the pole lies on the equator. Trace the longitude that is 90° away from the pole. Note that every point on this subtends 90° with the pole. This is illustrated in figure 11.

Problem: Find the line of intersection between two planes if the locations of their poles are shown on stereographic projection. See figure 12.

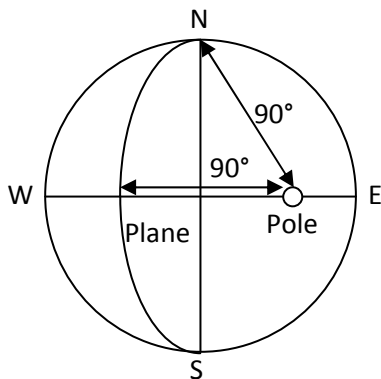

Figure 11: Shows how to trace the plane for a given pole. EWNS poles are indicated to show position of Wulff net. The longitude 90° away is the plane.

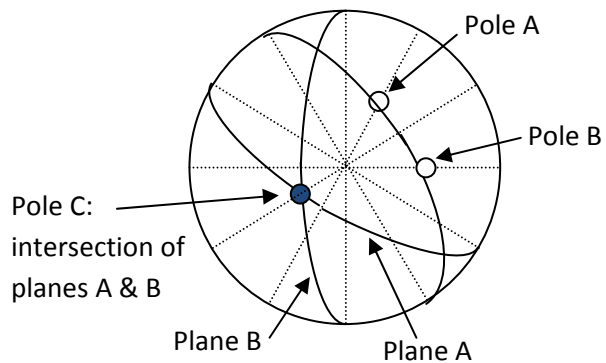

Figure 12: Shows how to find line of intersection of planes corresponding to poles A & B. Note it can be done in two ways: either by tracing respective planes or by locating pole of the plane containing A & B

Standard projection of a cubic crystal

Standard projection displays relative positions of different poles of a crystal. Let us see how to construct such a projection of cubic crystal on a specific plane of the reference sphere. Figure 13 shows the way the crystal is placed at the centre of the sphere. Let (001) be the plane of projection. Locations of selected poles are also shown. Note how the pole 011 is projected on 001 plane.

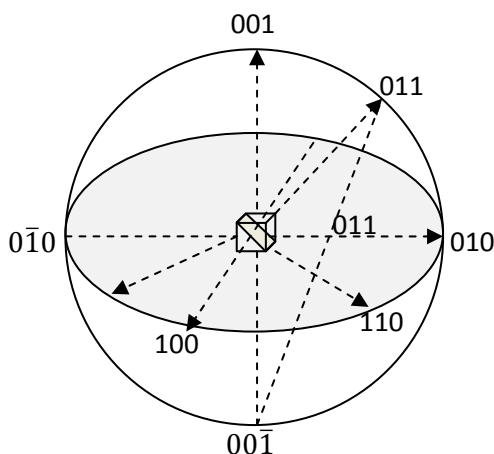

Figure 13: Displays how the crystal is placed at the centre of reference sphere

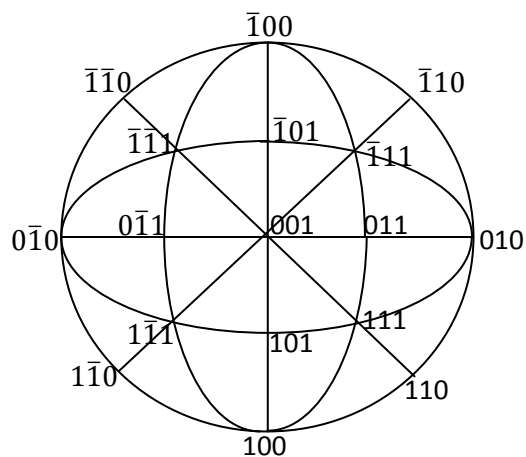

Figure 14: Standard 001 projection of a cubic crystal placed as shown in figure 13

Standard 001 projection showing positions of low indices planes are shown in figure 14. Wulff net and angular relationships between different planes and directions would help precise location of poles on the projection.

For a cubic crystal angles between two planes (ϕ) having Miller indices $(h_1k_1l_1)$ and $(h_2k_2l_2)$ is given by the following relation. The indices of plane normal and the plane are exactly the same if the axes are orthogonal.

$$\cos \phi = \frac{h_1h_2+k_1k_2+l_1l_2}{\sqrt{h_1^2+k_1^2+l_1^2}\sqrt{h_2^2+k_2^2+l_2^2}} \quad (1)$$

Therefore planes perpendicular to each other should satisfy the following relation:

$$h_1h_2 + k_1k_2 + l_1l_2 = 0 \quad (2)$$

On the standard projection you would notice that there are several poles lying on the same great circle. They all have a common direction. This represents their line of intersection. A set of such planes having a common line of intersection is said to belong to a zone. The line of intersection is called the zone axis. A look at the standard projection would reveal that planes having the following indices; 100, 110, 010, $\bar{1}10$, $\bar{1}00$, $\bar{1}\bar{1}0$, $0\bar{1}0$, $1\bar{1}0$ belong to a zone having 001 as its zone axis. Each of these poles satisfies equation 2 with 001.

Problem: Show that if poles $h_1k_1l_1$ and $h_2k_2l_2$ belong to zone $[uvw]$; any pole having indices $mh_1 \pm nh_2, mk_1 \pm nk_2, ml_1 \pm nl_2$ also belong to the same zone; where m & n are non-zero multipliers.

Answer: Since $[uvw]$ is the zone axis it should satisfy equation 2 with both the poles. Therefore

$$h_1u + k_1v + l_1w = 0 \quad (3)$$

$$h_2u + k_2v + l_2w = 0 \quad (4)$$

On multiplying equation 3 by m and 4 by n and adding (or subtracting) the two one gets:

$$(mh_1 \pm nh_2)u + (mk_1 \pm nk_2)v + (ml_1 \pm nl_2)w = 0 \quad (5)$$

Therefore poles having indices $mh_1 \pm nh_2, mk_1 \pm nk_2, ml_1 \pm nl_2$ belong to the same zone.

Problem: How would you plot the location of pole hkl of a cubic crystal on a standard projection?

Answer: Positions of the cube poles on the projection are known (or can be easily located). To locate hkl one needs to find the angles between the three cube axes and the pole. This is illustrated in the following figure. Using equation 1 one gets the direction cosines with respect to crystal axes.

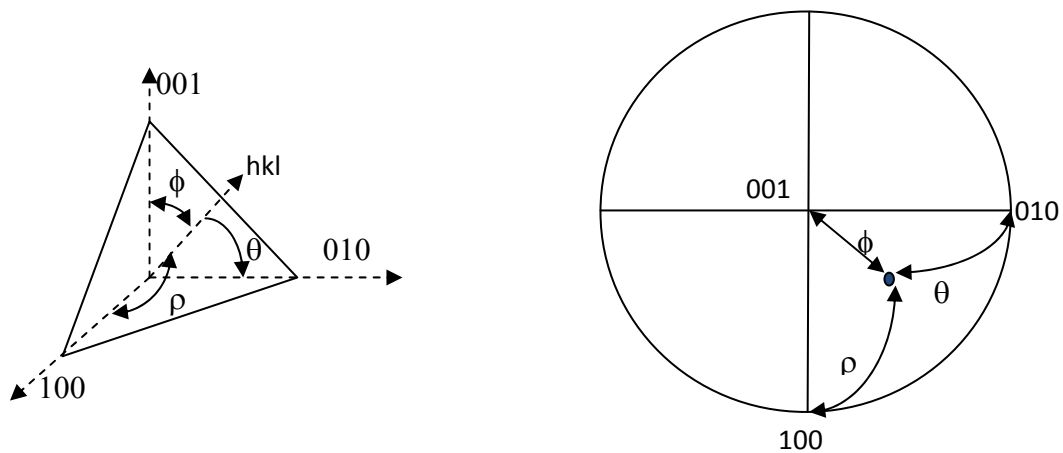

Figure 15: Shows plane hkl and its normal. The angles between the plane normal and crystal axes are given by $\cos \rho = \frac{h}{\sqrt{h^2+k^2+l^2}}$; $\cos \theta = \frac{k}{\sqrt{h^2+k^2+l^2}}$; $\cos \phi = \frac{l}{\sqrt{h^2+k^2+l^2}}$. Once the angles are known the pole can be located on the projection as shown above. Wulff net should be used to measure the angles.

The location of the poles of similar planes on the standard projection gives an idea about crystal symmetry. This can be verified by performing rotation operation about a specific direction. Cube axis is known to be an axis of four fold symmetry. If a crystal is rotated by 90° about it should come to an identical position. It is evident that similar poles are located in identical fashion in each of the four quadrants. Therefore 90° rotation about 001 would bring similar poles to identical locations. If you try to give 120° rotation about 111 you would find the poles come to occupy similar positions. Therefore it is an axis of 3 fold symmetry. Likewise you can show that 110 is an axis of 2 fold symmetry. Rotation operations can be used to convert 001 projection to 110 or 111 standard projections.

How to plot locations of poles of high indices planes?

This can be done in two ways. The direct method is to convert Miller indices to angles the pole subtends with the crystal axes and use these to locate the pole. The method has been illustrated in one of the solved examples. A more elegant method is to use the concept of zone & zone axis. Let us see how we could locate positions of poles of type $\langle 112 \rangle$. If poles $h_1k_1l_1$ and $h_2k_2l_2$ belong to zone $[uvw]$; any pole having indices $mh_1 \pm nh_2, mk_1 \pm nk_2, ml_1 \pm nl_2$ also belong to the same zone; where m & n are non-zero multipliers. Planes belonging to the same zone lie on the same great circle. If $m = n = 1$, pole 112 should lie on the zone containing 111 and 001 as well as on the zone containing 101 and 011. Zone (or the plane) containing 001 & 111 is already drawn. Although it appears as a straight line in reality it represents a great circle. Trace the great circle (longitude) by placing it over Wulff net so that its NS axis coincides with line joining poles $\bar{1}10$ with $1\bar{1}0$. Figure 16 illustrates how two additional great circles have been plotted. A few of these have been indexed. There are 12 such poles. Two more great circles are to be drawn. Try this as an exercise.

2.

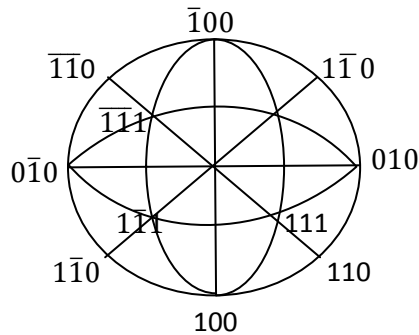

3. The crystal (dimension) is assumed to be a point to construct a stereographic projection of a crystal. All planes in the crystal would therefore pass through the centre of the reference sphere. Crystal planes like (100), (200), (300) etc are all coincident.
4. A pole hkl in a stereographic projection represents a normal to the plane (hkl). It is therefore a direction in 3D. The angle measurement is done on plane passing through the two directions. A great circle in a Wulff net represents a plane. Therefore to measure the angle the two poles the Wulff net is so kept that both the poles lie on a great circle.

