

Wave energy

- Wave energy is an irregular and oscillating low frequency energy source that can be converted to a 50 Hertz frequency and can then be added to the electric utility grid.
- Waves get their energy from the wind, which comes from solar energy.
- Waves gather, store, and transmit this energy thousands of kilometers with very little loss.
- Though it varies in intensity, it is available twenty four hours a day all round the year.

Wave energy-1

- Wave power is renewable, pollution free and environment friendly. Its net potential is better than wind, solar, small hydro or biomass power.
- Wave energy technologies rely on the up-and-down motion of waves to generate electricity.
- There are three basic methods for converting wave energy to electricity.
- **Float or buoy systems** that use the rise and fall of ocean swells to drive hydraulic pumps.
- The object can be mounted to a floating raft or to a device fixed on the ocean bed.
- A series of anchored buoys rise and fall with the wave.
- The movement is used to run an electrical generator to produce electricity which is then transmitted ashore by underwater power cables.

Wave energy-2

- **Oscillating water column devices** in which the in-and-out motion of waves at the shore enters a column and force air to turn a turbine.
- The column fills with water as the wave rises and empties as it descends.
- In the process, air inside the column is compressed and heats up, creating energy.
- This energy is harnessed and sent to shore by electrical cable.
- **Tapered channel** rely on a shore mounted structure to channel and concentrate the waves driving them into an elevated reservoir.
- Water flow out of this reservoir is used to generate electricity using standard hydropower technologies.

Wave energy-3

Power of waves inspires ingenuity

Oscillating Water Column

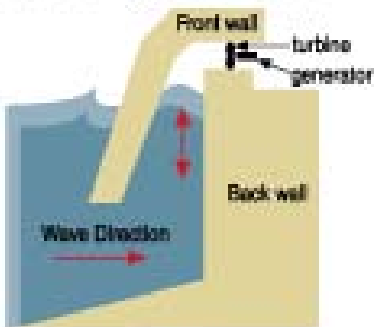

Waves push air through turbine, then suck it back, as they advance and recede. Devices operate onshore (above) or offshore.

Pelamis

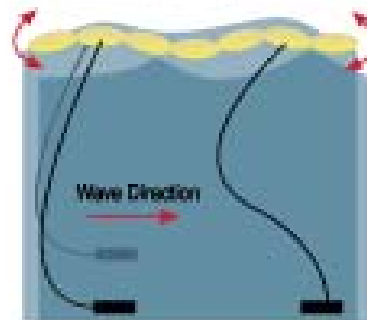

Serpentine device flexes in oncoming waves. Pivoting of segments drives pistons that pressurize oil, which runs generators.

McCabe Wave Pump

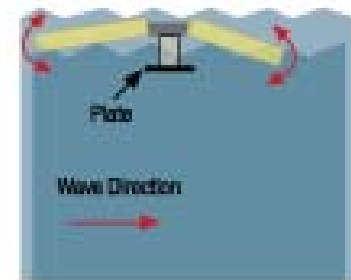

Bobbing of outer barges, hinged to central barge stabilized by underwater plate, runs pumps.

Archimedes Wave Swing

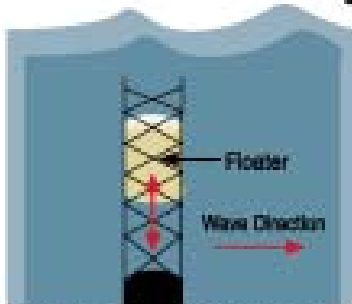

Air tank in fixed, submerged tower rises and falls with passing waves. The oscillations turn a generator shaft.

Nodding Duck

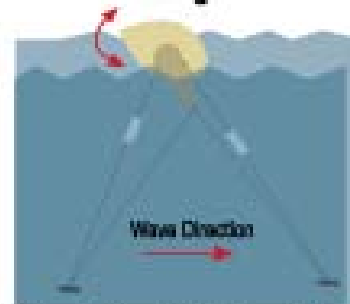

Waves tip beak of floating device (seen on end). Beak's rotation relative to central shaft pumps oil, which drives generator.

IPS Buoy

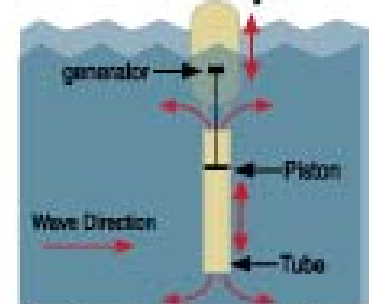

Seawater inside open-ended tube stabilizes piston. Motion of bobbing buoy relative to piston shaft drives generator.

Wave energy-4

The advantages of wave energy are as follows:

- Because waves originate from storms far out to sea and can travel long distances without significant energy loss.
- power produced from them is much steadier and more predictable day to day and season to season.
- Wave energy contains about 1000 times the kinetic energy of wind.
- Unlike wind and solar energy, energy from ocean waves continues to be produced round the clock.
- Wave power production is much smoother and more consistent than wind or solar resulting in higher overall capacity factors.

Wave energy-5

- Wave energy varies as the square of wave height whereas wind power varies with the cube of air speed.
- Water being 850 times as dense as air, this result in much higher power production from waves averaged over time.
- Because wave energy needs only 1/200 the land area of wind and requires no access roads, infrastructure costs are less.
- Wave energy can be considered as a concentrated form of solar energy.
- Winds are generated by the differential heating of the earth. As they pass over open bodies of water they transfer some of their energy to form waves.

Wave energy-6

Three main processes appear to be operating are:

- Initially air flowing over the sea exerts a tangential stress on the water surface, resulting in the formation and growth of waves.
- Turbulent airflow close to the water surface creates rapidly varying shear stresses and pressure fluctuations.
- Where these oscillations are in phase with existing waves, further wave development occurs.
- Finally, when waves have reached a certain size, the wind can actually exert a stronger force on the upwind face of the wave causing additional wave growth.
- The process is maximized when the speeds of the wind and waves are equal.

Wave energy-7

- Energy is transferred from the wind to the waves at each of these steps.
- The amount of energy transferred, and hence the size of the resulting waves, depends on the wind speed, the length of time for which the wind blows and the distance over which it blows (the fetch).
- At each stage in the process, power is concentrated so that solar power levels of about 100W/m^2 eventually transformed into waves with power levels of over 1,000 kW per meter of crest length.
- Oceans cover three-quarters of the earth's surface and represent a large natural energy resource, estimated by the World Energy Council (1993) as ~ 2 TW.
- The IEA (1994) has indicated that wave energy may eventually provide over 10% of the world's electricity supply.

Estimation Of Power Associated With Waves

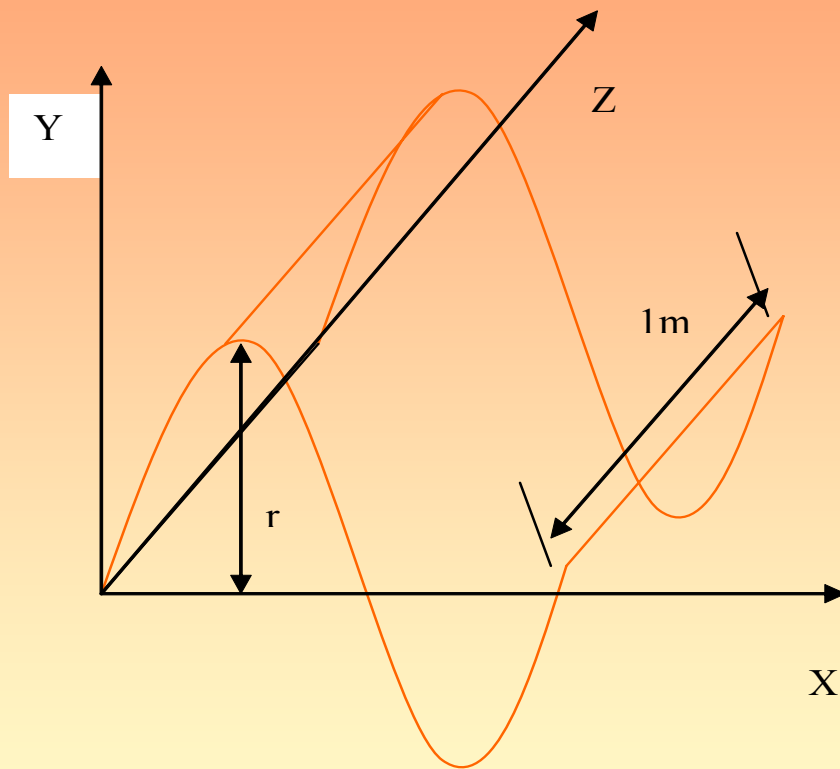

Fig: A Wave of unit Width and amplitude r moving along x-direction

_____ Ocean Surface

Estimation Of Power Associated With Waves-1

- Let the amplitude of the wave at the surface of the wave be 'a'.
- Wave is traveling in the x-direction.
- Wave amplitude is in Y direction.

$$r = ae^{ky}$$

- Where r is amplitude of wave at distance y in the negative direction.
- It means that the amplitude of oscillations of particles decreases as we move in to the depth of the sea.

Estimation Of Power Associated With Waves-2

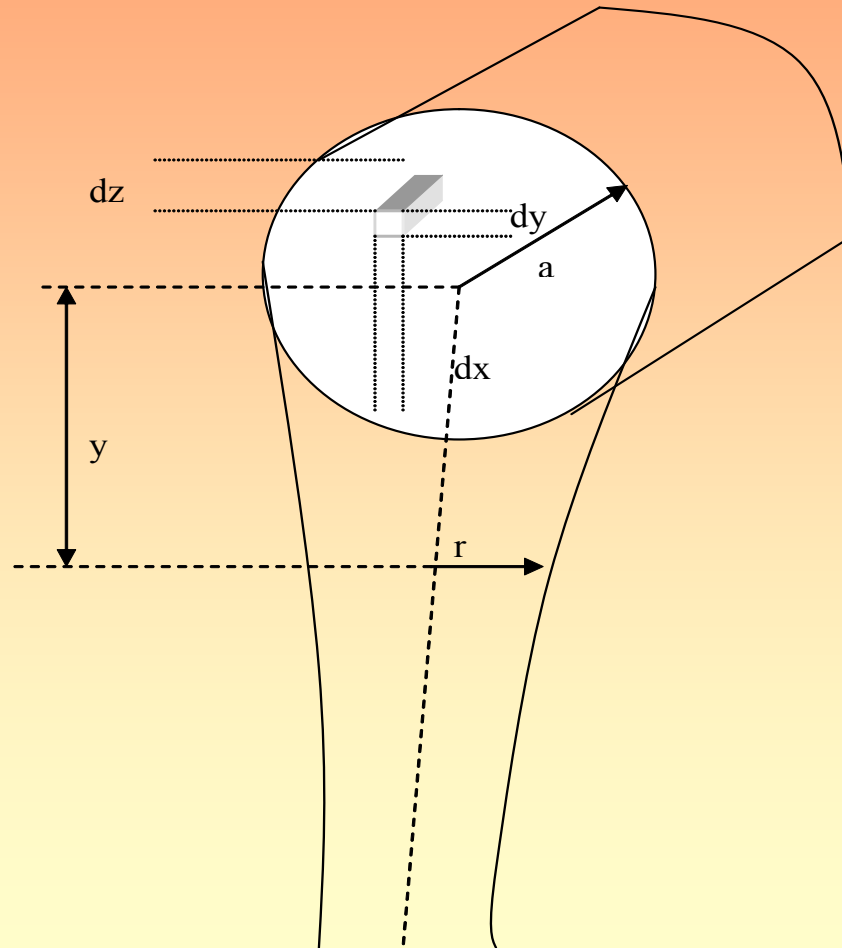

Estimation Of Power Associated With Waves-3

$$dv = dx \cdot dy \cdot dz$$

$dx \cdot dy$ is the volume per unit width of the wave.

E_k = kinetic energy per unit length in X direction.

$$dE_k \cdot dx = \text{K.E of particle of width } dx$$

$$= (1/2)mv^2$$

$$= (1/2) \cdot dx \cdot dy \cdot \rho \cdot v^2$$

$$= (1/2) \cdot dx \cdot dy \cdot \rho \cdot (\omega \cdot r)^2$$

$$dE_k = (1/2) \cdot dy \cdot \rho \cdot (\omega \cdot r)^2$$

$$= (1/2) \cdot \rho \cdot \omega^2 \cdot a^2 \cdot e^{2y} \cdot dy$$

$$\int_{-\infty}^0 dE_k = (1/2) \cdot \rho \cdot \omega^2 \cdot a^2 \cdot \int_{-\infty}^0 e^{2y} \cdot dy$$

$$= \rho \cdot \omega^2 \cdot a^2 / (4 \cdot K)$$

Estimation Of Power Associated With Waves-3

$$K=2\pi/\lambda$$

$$\lambda=2\pi g/\omega^2$$

$$E_k=(1/4).\rho.a^2.g$$

$$E_p=(1/4).\rho.a^2.g$$

$$\text{Total wave energy}=(1/2)*.\rho.a^2.g$$

$$E\lambda=(1/4)*\rho.a^2.g.\lambda$$

$$=(1/4\pi).\rho.a^2.T^2$$

Power associated with the wave per unit width, P/unit width

$$=(1/8\pi)\rho a^2 g^2 T$$

Estimation Of Power Associated With Waves-4

- Water waves can be considered to travel along the surface of the sea with an approximate sinusoidal profile.
- They can be characterized in terms of the distance between successive crests (the wavelength, λ) and the time between successive crests (the period, T).
- In deep water these parameters are related as follows

$$\lambda = gT^2 / 2\pi$$

Where g is the acceleration due to gravity.

- The velocity of the waves, C, is given by the following relationship:

$$C = \lambda / T$$

Estimation Of Power Associated With Waves-4

- Hence, longer waves travel faster than shorter ones.
- This effect is seen in hurricane areas, where long waves generally travel faster than the storm generating them and so the arrival of the hurricane is often preceded by heavy surf on the coast.
- The power (P) in such waves can also be described by use of these parameters and the wave height, H:

$$P = \rho g^2 T H^2 / 32\pi$$

Where ρ is the density of seawater and P is expressed per unit crest length of the wave.

- Most of the energy within a wave is contained near the surface and falls off sharply with depth.

Estimation Of Power Associated With Waves-4

- In nature, waves are irregular and can be described by statistical models.
- If the wave conditions are measured, over 20 minutes for example, the mean wave height H_m and the significant wave height H_s can be calculated.
- The significant wave height is defined as the average of the highest 33% of the waves. Under such circumstances, the wave power can be stated to be:

$$P = 0.55 H_s^2 T_z \text{ kW/m length of wave crest}$$

Where T_z is the zero crossing period [Charlier, Justus 1993]

Problems Associated With Utilization Of Wave Energy

- The first problem is shortage of wave data, especially close to the shore.
- The required information includes the record of wave height with time and directional properties of the wave.
- The second problem relates to effect of the wave forces on the structures of the devices.
- A device, which absorbs or reflects wave energy must also absorb or reflect momentum and must be subjected to mean horizontal force.
- This force must be balanced by an opposing force provided by fixing the device to seabed or by arranging for opposing forces to be exerted by the sea on other parts of the devices.

Problems Associated With Utilization Of Wave Energy-1

- The third problem concerns the power generation from slow irregular motion of waves to the steady high-speed rotary motion normally required for electrical machines.
- The transmission of this power to ashore may also be difficult if flexible cables are required.
- The fourth problem leads to effects of devices on the environment.
- Changes in the wave climate caused by wave energy converters could affect the local shoreline.
- Fish feeding and spawning could be affected by these devices, which would also present some hazard to fishing.

Problems Associated With Utilization Of Wave Energy-2

Wave Energy collecting devices:

➤ **SHORELINE DEVICES**

- a) Oscillating Water Column (OWC) Devices
- b) Tapered Channel Devices (TAPCHAN)
- c) The Pendulum Device

➤ **OFFSHORE DEVICES**

- a) Float-Based Devices
- b) Moving body Devices

Shoreline Devices

- These devices are fixed to or embedded in the shoreline itself, which has the advantage of easier maintenance and/or installation.
- In addition these would not require deep-water moorings or long lengths of underwater electrical cable.
- However, they would experience a much less powerful wave regime.
- This could be partially compensated by natural energy concentration.
- The deployment of such schemes could be limited by requirements for shoreline geology, tidal range, preservation of coastal scenery, etc.

Oscillating Water Column (OWC) Devices

- One major class of shoreline device is the oscillating water column partly submerged concrete or steel structure, which has an opening to the sea below the water line, thereby enclosing a column of air above a column of water.
- As waves impinge on the device, they cause the water column to rise and fall, which alternately compresses and depressurizes the air column.
- This air is allowed to flow to and from the atmosphere through a turbine, which drives an electric generator .
- Both conventional (i.e. unidirectional) and self- rectifying air turbines have been proposed.

Oscillating Water Column (OWC) Devices-1

- The axial-flow Wells turbine, invented in the 1970s, is the best-known turbine for this kind of application and has the advantage of not requiring rectifying air valves.
- A number of OWC devices have been installed world wide, with several of them being built into a breakwater to lower overall construction costs.

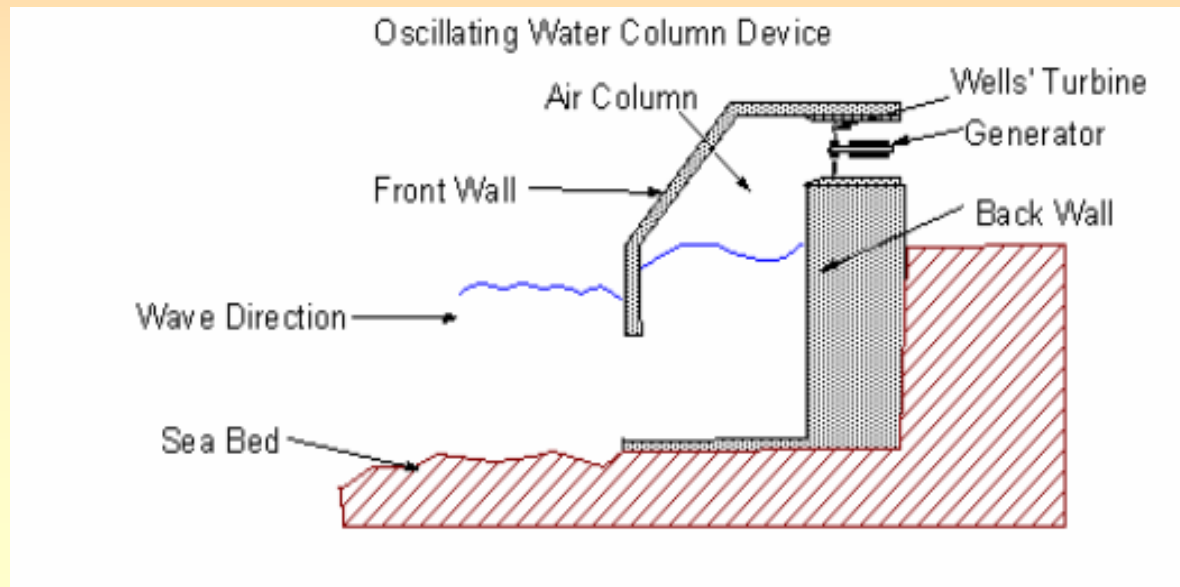

Tapered Channel Devices (TAPCHAN)

- The TAPCHAN comprises a gradually narrowing channel with wall heights typically 3 to 5 m above mean water level.
- Waves enter the wide end of the channel and, as they propagate down the narrowing channel, the wave height is amplified until the wave crests spill over the walls to the reservoir, which is raised above sea level.
- The water in the reservoir returns to the sea via a conventional low head turbine, which generates a stable output due to the storage effects of the reservoir.
- A demonstration device with rated output of 350 kW began operating in 1985 at Toftesfallen, in Norway.

Tapered Channel Devices (TAPCHAN)-1

- The device functioned successfully until the early 1990s, when work on modifying the device destroyed the tapered channel.
- The potential market for such a device is limited within Europe, because the design requires a small tidal range.

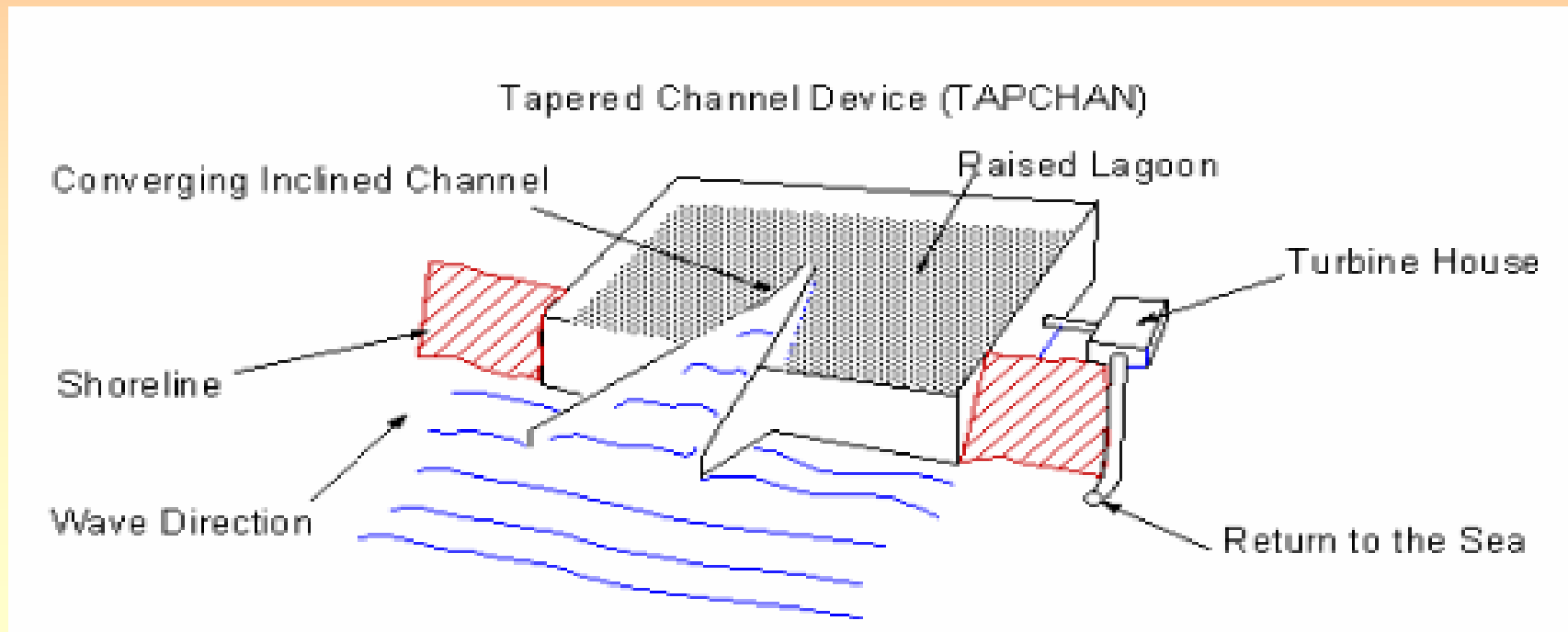

The Pendulor Device

- A 5 kW Pendulor test device has been operating in Hokkaido since 1983.
- It consists of a rectangular box, which is open to the sea at one end.
- A pendulum flap is hinged over this opening, so that the actions of the waves cause it to swing back and forth.
- This motion is then used to power a hydraulic pump and generator.

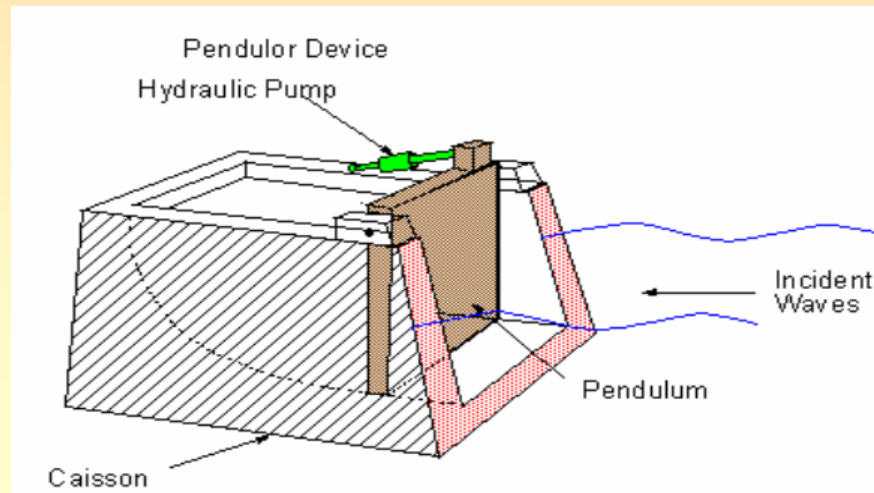

Offshore Devices

- This class of device exploits the more powerful wave regimes available in deep water (> 40 m depth) before energy dissipation mechanisms have had a significant effect.
- In order to extract energy from the waves, the devices need to be at or near the surface (i.e. floating) and so they require flexible moorings and electrical transmission cables.
- There are many different types of offshore device, some of which are:

Float-Based Devices

- The simplest concepts extract energy from the vertical motion of a float as it rises and falls with each wave.
- If the motion of the float is reacted against an anchor or other structure that resists motion, then energy can be extracted.

Offshore Devices-1

- In the Danish Wave Power (DWP) device, this is achieved by anchoring the float to a pump and generator mounted in a concrete box on the seabed (DWP, 1996; Nielsen et al, 1995).
- Following developmental work, a 1 kW test device was installed near the harbor of Hanstholm, Denmark.
- This incorporated an air reservoir, which acted as an energy storage system, thereby smoothing the device output.
- After some initial difficulties, this device performed continuously for several months providing considerable amounts of information.

Offshore Devices-2

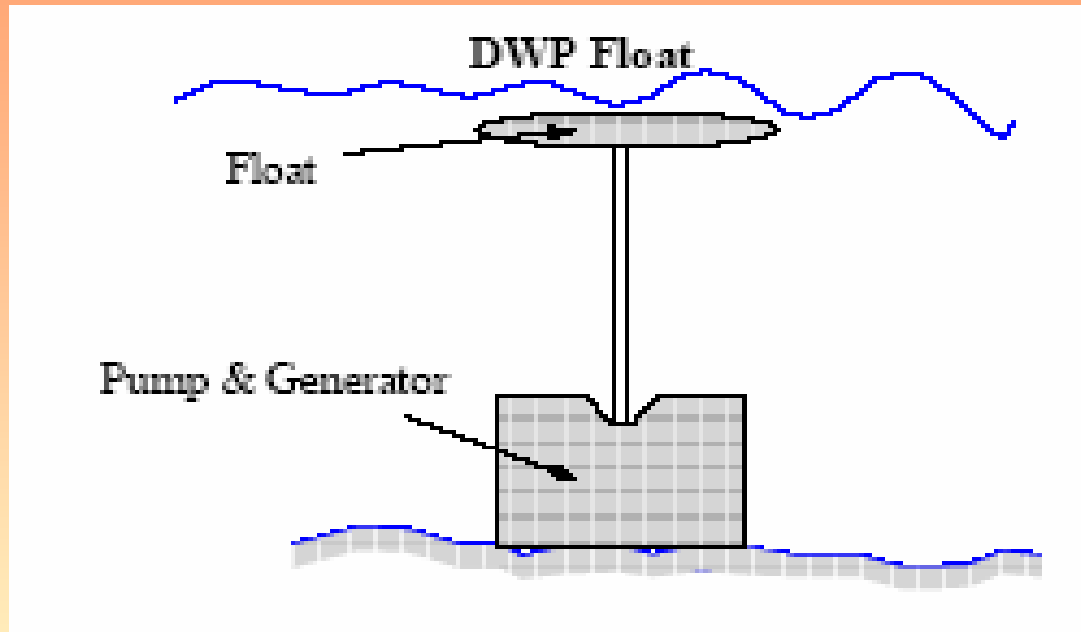

- Another example of a device using a float is based on the Hose pump, which is a specially reinforced elastomeric hose whose volume decreases as it is stretched.
- The interior of the Hose pump is filled with seawater, which is pressurized as the float rises.

Offshore Devices-3

- By using a non-return valve, the device can supply pressurized seawater to a line connecting several Hose pump modules together.
- This line supplies seawater to a conventional Pelton turbine at pressures between 1 and 4 MPa).
- Later a larger system, comprising five modules connected in parallel to a single turbine and generator, was installed in Lake Lygnern.
- Despite loss of early systems in storms, a costing exercise was carried out on a 64 MW station comprising 360 modules for emplacement off the Norwegian coast (GES, 1984).
- The performance of the system was good enough to encourage recent interest in commercial exploitation in using Hose pumps to power navigation buoys.

Offshore Devices-4

- The performance of the system was good enough to encourage recent interest in commercial exploitation in using Hose pumps to power navigation buoys.

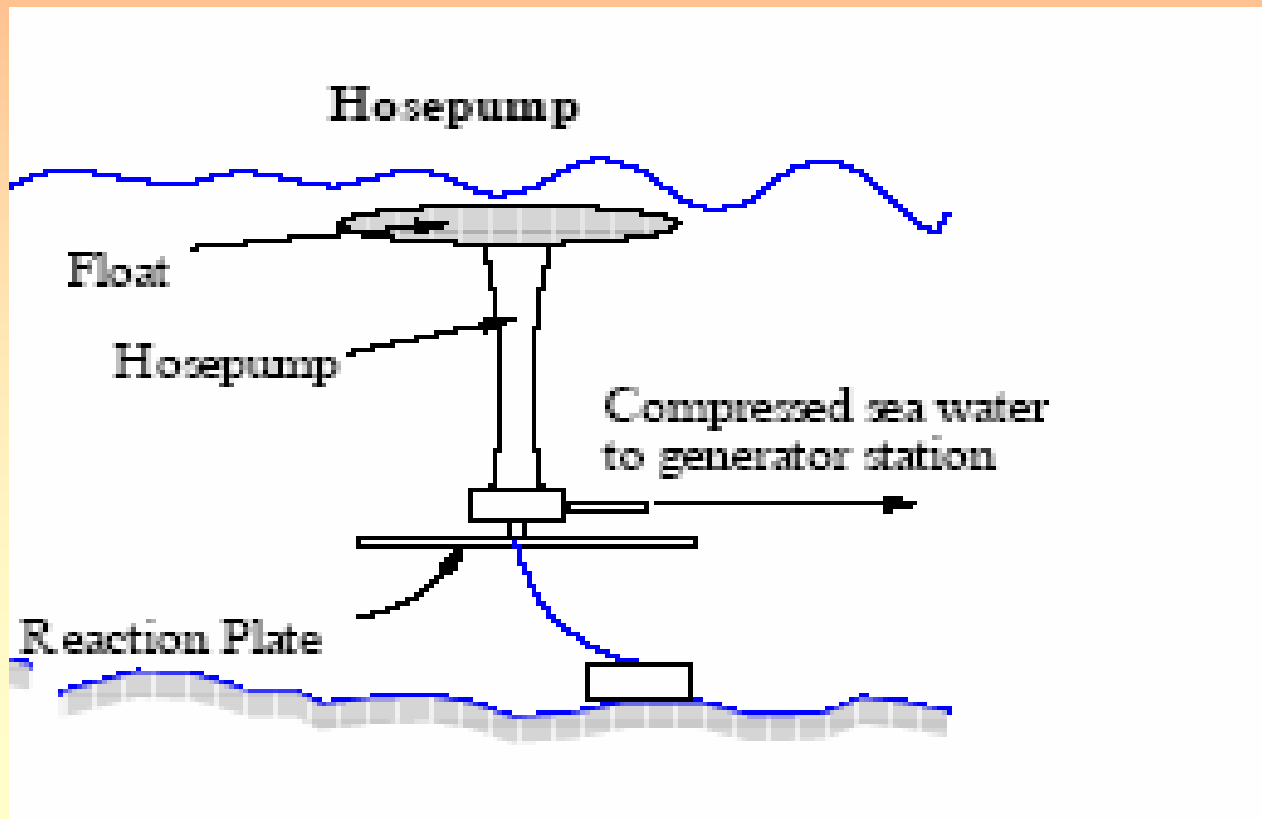

Offshore Devices-5

The Pelamis:

- The Pelamis device is a semi-submerged, articulated structure composed of cylindrical sections linked by hinged joints.
- The wave-induced motion of these joints is resisted by hydraulic rams, which pump high-pressure oil through hydraulic motors via smoothing accumulators.
- The hydraulic motors drive electrical generators to produce electricity.
- A novel joint configuration is used to induce a tuneable, cross-coupled resonant response, which greatly increases power capture in small seas and control of the restraint applied to the joints allows tuning to the particular sea state.

Offshore Devices-6

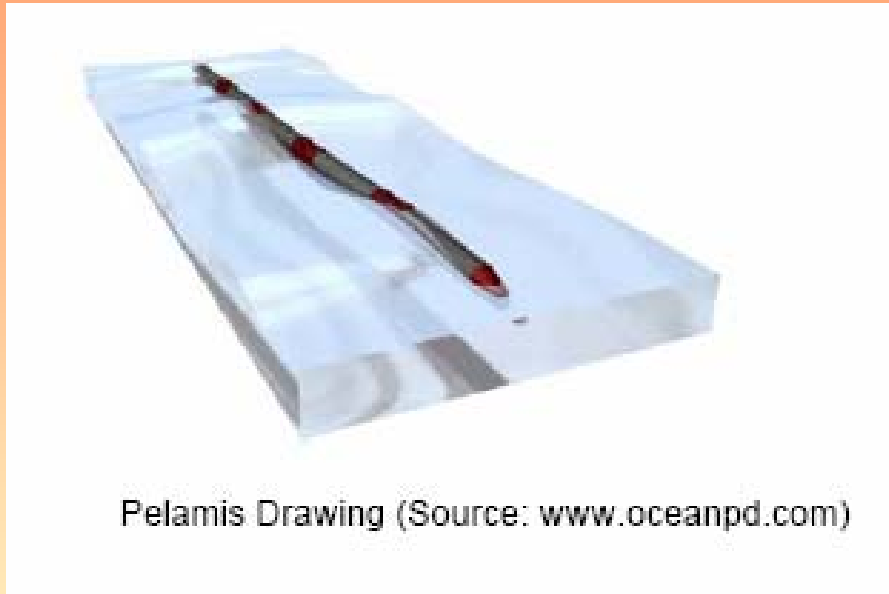

The Archimedes Wave Swing

- This consists of a cylindrical, air filled chamber (the “Floater”), which can move vertically with respect to the cylindrical “Basement”, which is fixed to the seabed.

Offshore Devices-7

- The air within the 10m – 20m diameter Floater ensures buoyancy.
- However, a wave passing over the top of the device alternatively pressurizes and depressurizes the air within the Floater, changing this buoyancy.
- This causes the Floater to move up and down with respect to the Basement and it is this relative motion that is used to produce energy.
- The design for a 2 MW Pilot scheme is currently being finalized

Offshore Devices-8

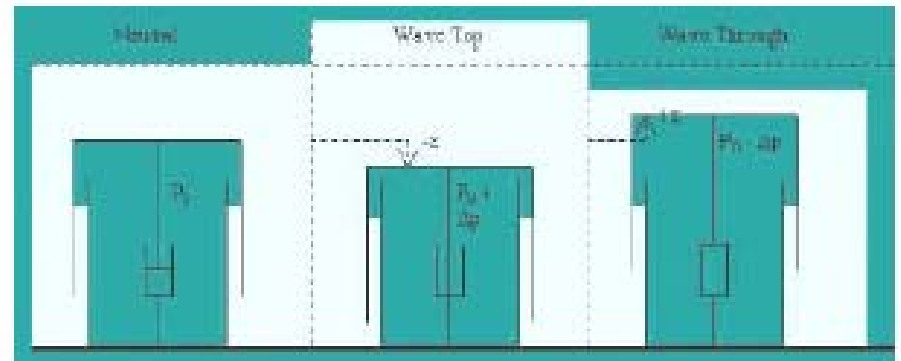

• AWS Above-surface and Technical Principle (Source: www.waveswing.com)

Offshore Devices-9

- The status of these designs is slightly less advanced than that for OWCs.
- However, several devices have been tested in the sea at near full size and so are ready for commercial demonstration.
- All these devices will continue to benefit from ongoing R&D.

The McCabe Wave Pump:

- This device consists of three narrow (4 m wide) rectangular steel pontoons, which are hinged together across their beam .
- These pontoons are aligned so that their longitudinal direction heads into the incoming waves and they can move relative to each other in the waves.

Offshore Devices-10

- The essential aspect of the scheme is the damper plate attached to the central pontoon this increases the inertia of the central pontoon (by effectively adding mass), ensuring that it stays relative still.
- Therefore, the fore and aft pontoons move in relation to the central pontoon by pitching about the hinges.
- Energy is extracted from the rotation about the hinge points by linear hydraulic rams mounted between the central and two outer pontoons near the hinges.
- Control of the characteristics of the hydraulic system allows the device to be tuned to the prevailing sea state and so optimize energy capture.

Offshore Devices-11

- This energy can be used in two ways:
- To provide electricity by driving an hydraulic motor attached to a generator, with a rating of ~ 400 kW .
- To produce potable water by supplying pressurized seawater to a reverse osmosis plant.
- A 40 m long prototype of this device was deployed off the coast of Kilbaha, County Clare, Ireland and a commercial demonstration scheme is currently being built.

Offshore Devices-12

Outline of the McCabe Wave Pump

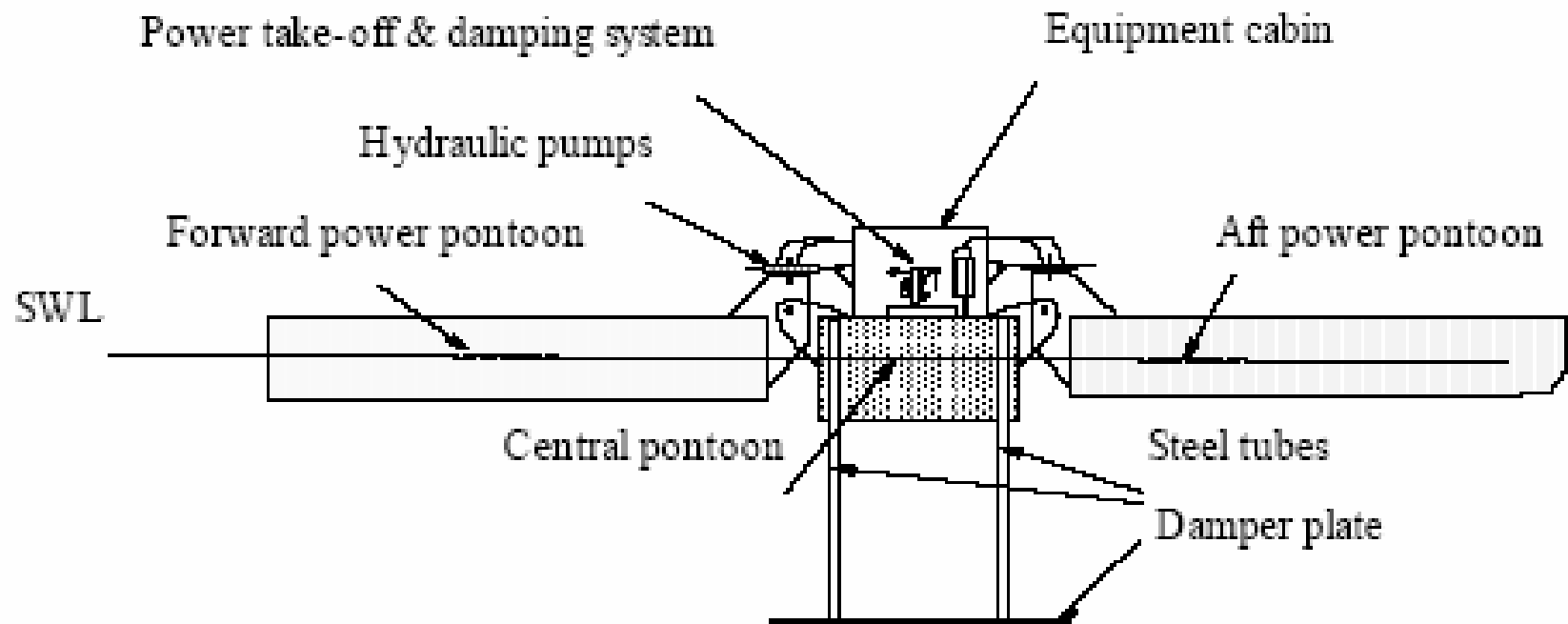

Offshore Devices-13

Mooring Arrangement for the McCabe Wave Pump

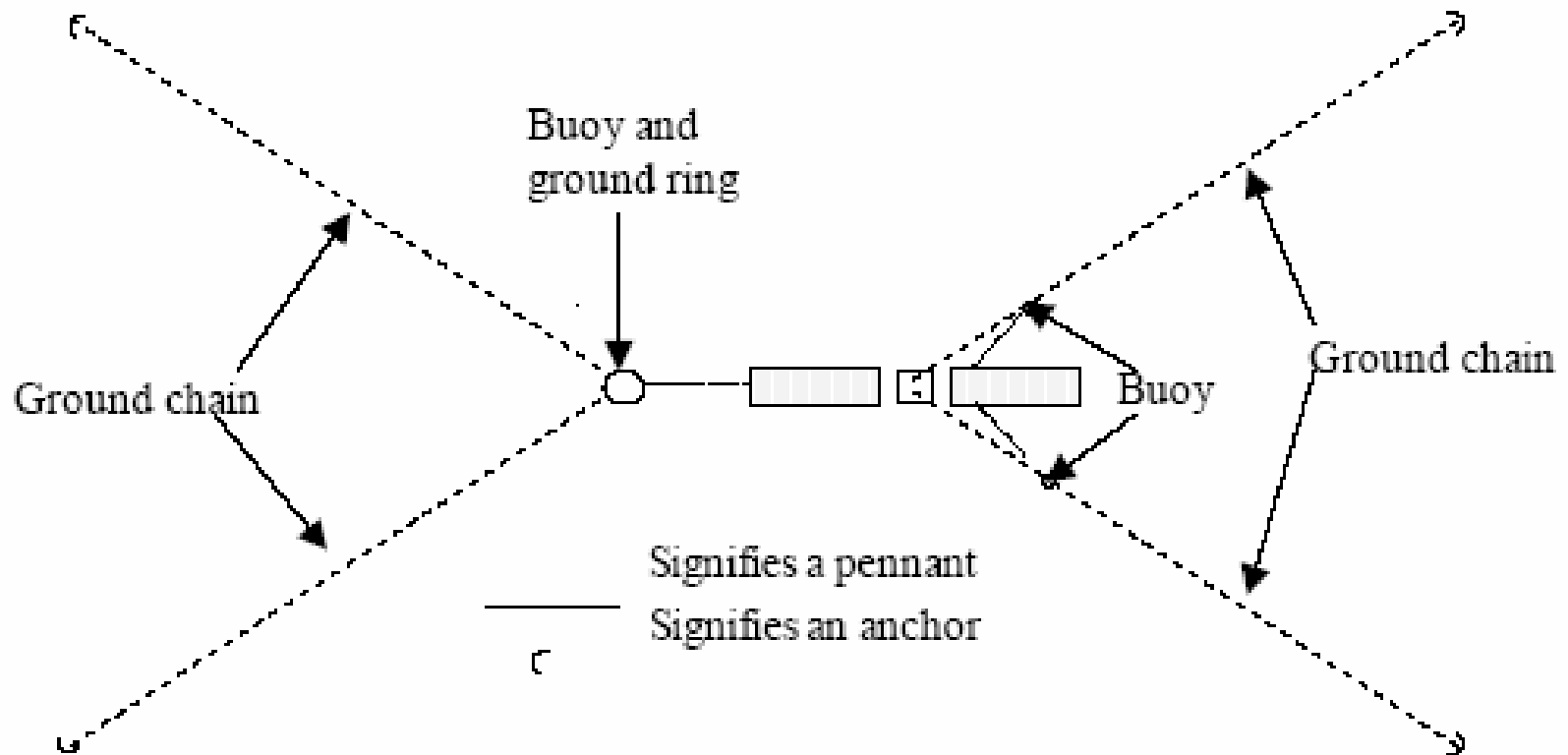

Offshore Devices-14

- There are some experimental data from small-scale tests, together with a short period of observations on the prototype.
- These indicate that the MWP can have capture efficiencies $>100\%$.
- In order to evaluate the performance of the MWP in a range of sea states, its behavior has to be evaluated theoretically.
- With different wave energy periods (T_e) and the resulting capture efficiency is shown in Figure.
- This shows a slight reduction in capture efficiency at short wave periods, when compared to the capture efficiency in regular seas.

Offshore Devices-15

Predicted Capture Efficiency of an MWP in Real Seas

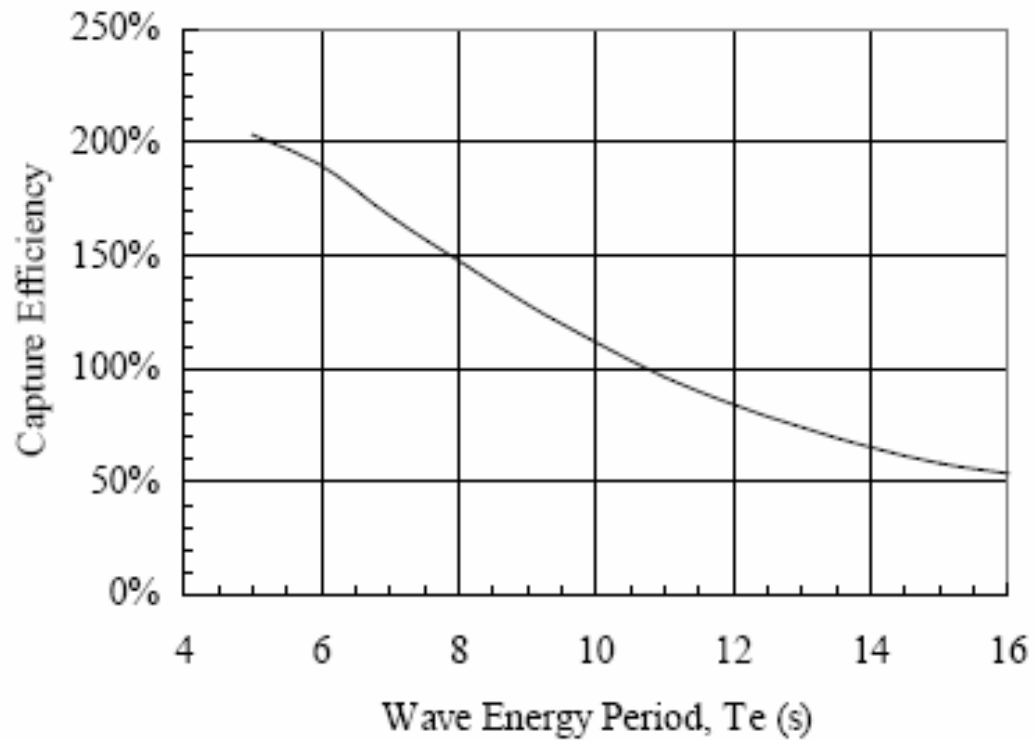

Offshore Devices-16

- The above predictions apply only to the fore pontoon. However, the aft pontoon will also capture wave energy.
- It is difficult to determine this theoretically but observations made on the prototype suggest that the aft pontoon picks up ~60% of the energy captured by the fore pontoon.
- The average capture efficiency was approximately 150%.

Offshore Devices-17

Characteristics of the MWP

Device Width	4m
Sea Power Level	53kW/m
Capture Efficiency	150%
Hydraulic efficiency	98%
Efficiency of hydraulic motor	95%
Efficiency of generator	96%
Availability	90%
Average Output per Device	257KW
Annual output of scheme	2.25GWh

Shoreline Devices

Limpet (Land Installed Marine Powered Energy Transformer)

- The Limpet a 500KW device is a shoreline-based oscillating water column (OWC), which has been developed by Queen's University of Belfast and Wavegen of Inverness. Wavegen installed a Limpet on the Islay Island in 2000.
- Limpet follows the designer gully concept, in which the device is constructed and fixed in place close to the shoreline, being protected from the sea by a rock bund.
- When the device is completely installed, the bund is removed, allowing the sea access to the device.

Shoreline Devices-1

- The device consists of three water columns placed side by side in a man-made recess, which forms a slipway at an angle to the horizontal.
- In the current design for the island of Islay, the water column boxes are made from a steel-concrete-steel sandwich called BISTEEL, giving a device width of ~21 m.
- The device is anchored to the rock promontories on either side and to the base.
- Wave tank tests have shown that the inclined slope increases the capture efficiency.
- There are two low solidity, counter rotating Wells' turbines each rated at 500 kW.

Shoreline Devices-2

- The turbines are placed behind the OWC chambers and the associated electrical equipment is located behind the turbines.
- where it is protected from seawater splashes by a rock bund.
- Each set of turbines is protected by a sluice gate, which can prevent the turbines being subjected to green water in stormy seas.
- The turbines also have flywheels to smooth out energy supply, as well as blow out valves.

Shoreline Devices-3

Outline Side View of the Limpet

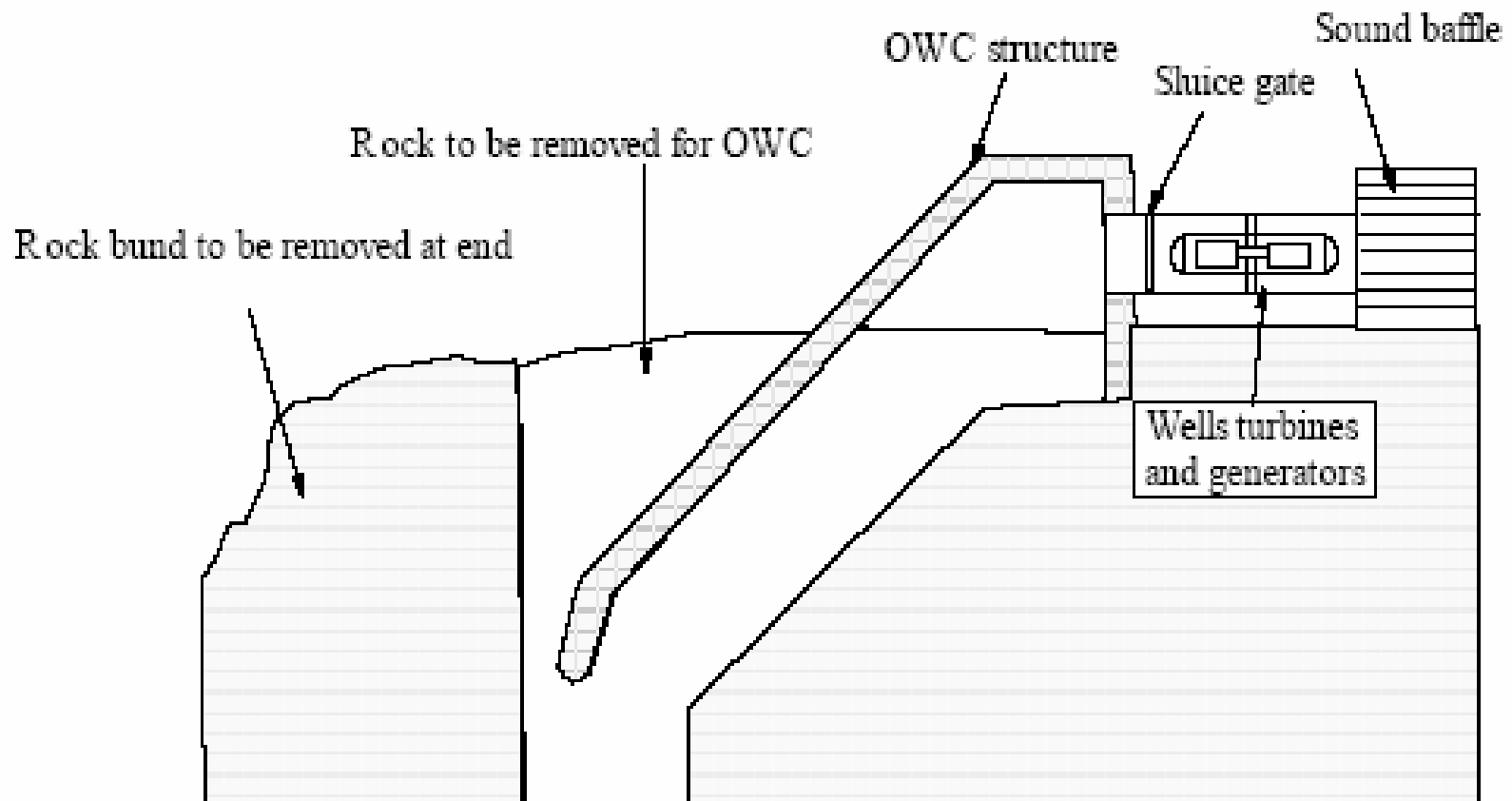

Shoreline Devices-4

Technical Considerations:

- The capture efficiency of the system has been proven in model testing but it is likely to be site-specific.
- The turbines are situated close to the OWC end of the air vents (\sim twice the turbine diameter), which could result in non-streamlined airflow and consequential loss of efficiency.
- However, Wavegen have studied this both theoretically and experimentally and consider it to have only a very small effect.
- The device has a design life of +30 years for the structure but that of the mechanical and electrical plant will be somewhat less.

Shoreline Devices-5

- **Replication Potential** The unit size will be ~ 1 MW allowing the system to integrate with nearly all parts of the grid.
- Wavegen have produced a modular system, tailored for deployment on islands and in remote locations.
- Therefore, the only limits on its replicability will be economic, geographic and environmental.
- **Geographic:** the scheme needs the right combination of shoreline topography and geography, together with low tidal ranges and closeness to the grid.

Shoreline Devices-6

- **Environmental:** the original Islay scheme impinged on the shoreline and had some visual impact.
- Wavegen have tried to address this in developing a low profile, composite roof, modular system with a much-reduced visual impact.
- They have also considered decommissioning of the device after service and have set aside monies to account for this.

Economic:

Capital Cost

- This is site-specific and subject to change following ongoing developments.
- There was a large degree of uncertainty in estimating these costs, because of the lack of detailed information, leading to predictions in the range £ 850,000 to £ 1,160,000 .

Shoreline Devices-7

Operational and Maintenance Costs

- The annual operation and maintenance costs were estimated to be approximately £ 23,000.
- The system is being developed with a view to it being maintained in remote locations by indigenous staff.

Electrical Output:

- The average wave power level at the Islay site is 20 kW/m. At this location, the device is estimated to have an average electrical output of 206 kW, amounting to 1,800 MWh/year.
- Details concerning certain aspects of the electrical output are commercially sensitive (e.g. capture efficiency of this sloped OWC chamber).

Shoreline Devices-8

- In addition, the energy output from this particular scheme is enhanced by the shape of the cliff, which forms sloping harbor walls either side of the OWC chamber, thereby increasing the effective capture width of the device.

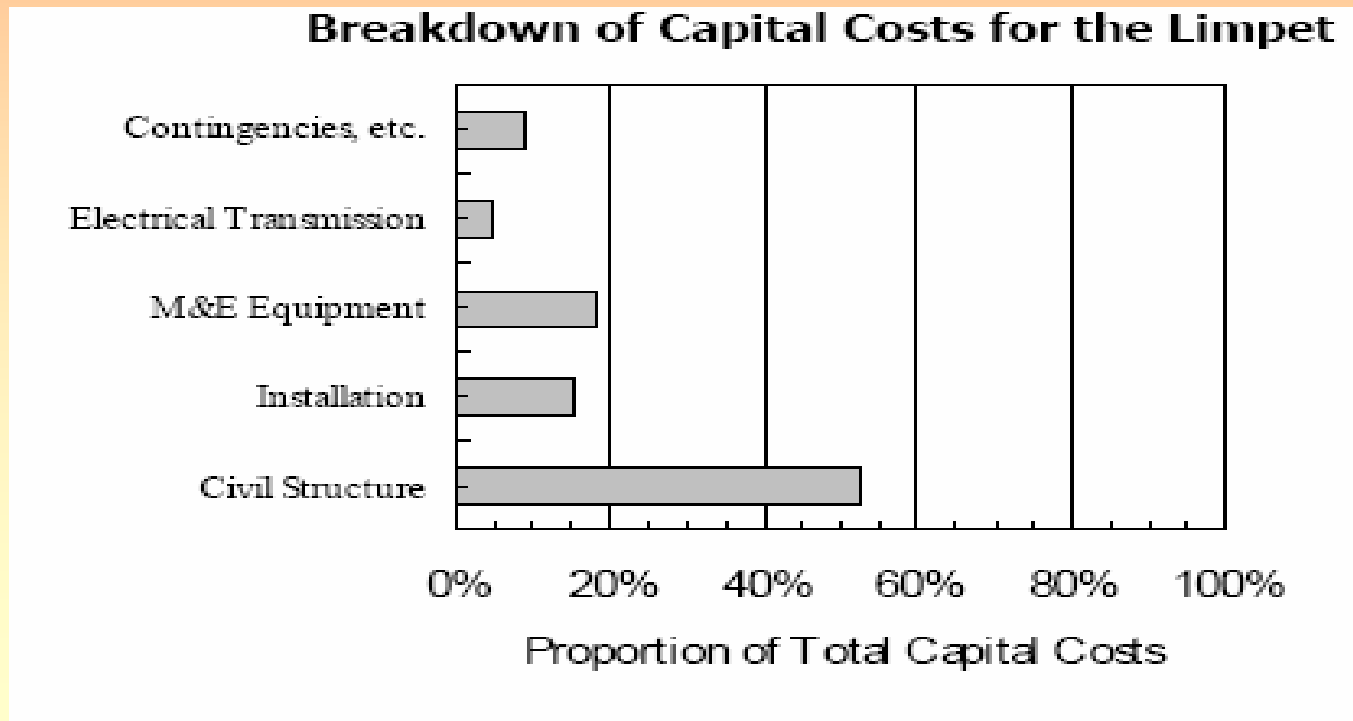

Shoreline Devices-9

POTENTIAL OF WAVE ENERGY IN INDIA:

- India has a coastline of approximately 7500 km. The average wave potential along the Indian coast is around 5-10 kW/m and peak monsoon average is around 20 kW/m. Even 10% utilization would mean a resource of 3750 –7500 MW.
- Hence it is an important alternative and renewable resource, as it can potentially provide vast amounts of electricity without pollution and the risk of fuel running out. Moreover protection of coastlines is a necessity for the life of millions of people living nears the coast.
- To connect the use of this renewable energy with the protection of the shore is an old dream of mankind.

Shoreline Devices-10

- Hence efforts are made to construct a wave energy breakwater, which also produces usable forms of energy from the wave power.
- A wave energy breakwater becomes profitable when compared to wave energy plant because the costs are shared between the breakwater wall and the power plant.
- An energy-absorbing breakwater is also a better engineering design as compared to a rubble-wall breakwater, which takes all the beating from the waves.
- Since India has a lot of potential for new fishing harbors and a large demand to construct these harbors in the near future, the development of new cost-effective breakwater systems is useful.

Shoreline Devices-11

- At present the idea of such a wave energy breakwater is not accepted in Europe .
- The European research into wave energy is focused on the development of a real wave power station.
- The double use of the construction is not popular here.
- Only the Greek project is based on the breakwater concept.
- From the point of view of the electricity producer the breakwater OWC has the advantage that the installation costs are reduced by sharing them with the harbor authorities (or similar) that want to shelter an area or a structure from the waves .

Shoreline Devices-12

- From the point of view of someone who wants to protect something against wave attack, the breakwater OWC has the advantage that sharing them with an electricity producer reduces the installation costs.
- It is also possible to use the breakwater structure as a pier for planned harbor activities.
- From the coastal engineering point of view the system has two large advantages over "normal" breakwaters:
 - a) The wave height in front of the device is reduced, as the wave energy is absorbed and not reflected.
 - b) The wave forces do not (only) act against the structure, they act to move the turbine, so the loads are reduced.

The Indian wave energy programme

- The Indian wave energy programme started in 1983 at the Institute of Technology, Madras and has concentrated almost exclusively on the OWC concept.
- The initial research conducted by the Wave Energy Group, IIT Chennai focused on the choice of the wave energy device (Raju, Ravindran 1987, Raju, Ravindran 1989).
- Based on studies on three types of devices, namely, double float system, single float vertical system, and the OWC principle, it was concluded that the OWC showed the maximum promise for India.
- Consequently, development activities were concentrated on this device alone.

The Indian wave energy programme-1

- The research on wave energy in India has achieved a commendable status within a decade.
- A caisson was constructed in December 1990 at Vizhinjam and two generations of power modules have been tested as of today.
- Efforts are on to make the technology cost-effective.
- A 150 kW prototype OWC With harbor walls was built onto the breakwater of the Vizhinjam Fisheries Harbor, near Trivandrum in India.
- Following the successful testing of this, it is proposed to build a commercial scheme of 10 caissons, each 21 m wide, at Thangassery, on the west coast of India.
- Each caisson will have two power modules, both with a 55 kW rating, leading to an overall rating of 1.1 MW.

Breakwater Owc

- The energy in the waves is converted by the OWC caisson into pneumatic energy.
- The power take-off mechanism is the Wells turbine connected to a generator.
- The generator delivers the electrical power to the grid.
- A part of the electrical power is also dissipated in the resistances externally connected to the rotor of the generator.
- The OWC wave energy device is a resonating device, which can be tuned to any predominant frequency of the wave by altering the dimensions of the device.

Breakwater Owc-1

- Theoretical analysis was done for a two-dimensional model with the assumption of potential flow conditions.
- For comparing the theoretical predictions, models were tested under two-dimensional wave conditions.
- These different models having rectangular and curved back walls, streamlined entry, etc. were tested in a 30 cm narrow wave flume, 90 cm wide wave flume, 2 m and 4 m flumes.
- Experimental optimization was also done with the inclusion of parallel guide walls for the waves to enter the device.

Design and installation of caisson

- The caisson is predominantly subjected to wave forces.
- The wave forces were estimated by treating the caisson as a vertical wall obstruction for the waves.
- The highest probably non-breaking wave force was 1200 tones.
- The highest probable breaking wave was estimated to be 7 m. The force intensity has a peak of 100 tones / m².
- The OWC with the harbor was built as a cellular concrete caisson. The design is of the gravity foundation type.
- The concrete structure weighs 3000 tones and is further ballasted in its hollow chambers using about 3000 tones of sand.

Design and installation of caisson-1

- This concrete ballasted caisson is seated on a prepared rubble bed.
- The top of the CWC chamber is a double cubic curved shell in concrete 10 x 7.75 m at the bottom, reducing to 2.0 m circle at the top and 3.0 m high to support the power module.
- Figure shows the cross-section of the wave energy device and breakwater.
- For conversion of pneumatic energy from the OWC to mechanical energy, the use of air turbines is required.
- Two turbine models with 263 mm diameter rotor were fabricated with blades of 100 mm and 65 mm chords.

Design and installation of caisson-2

- The tests were done with steady unidirectional airflow.

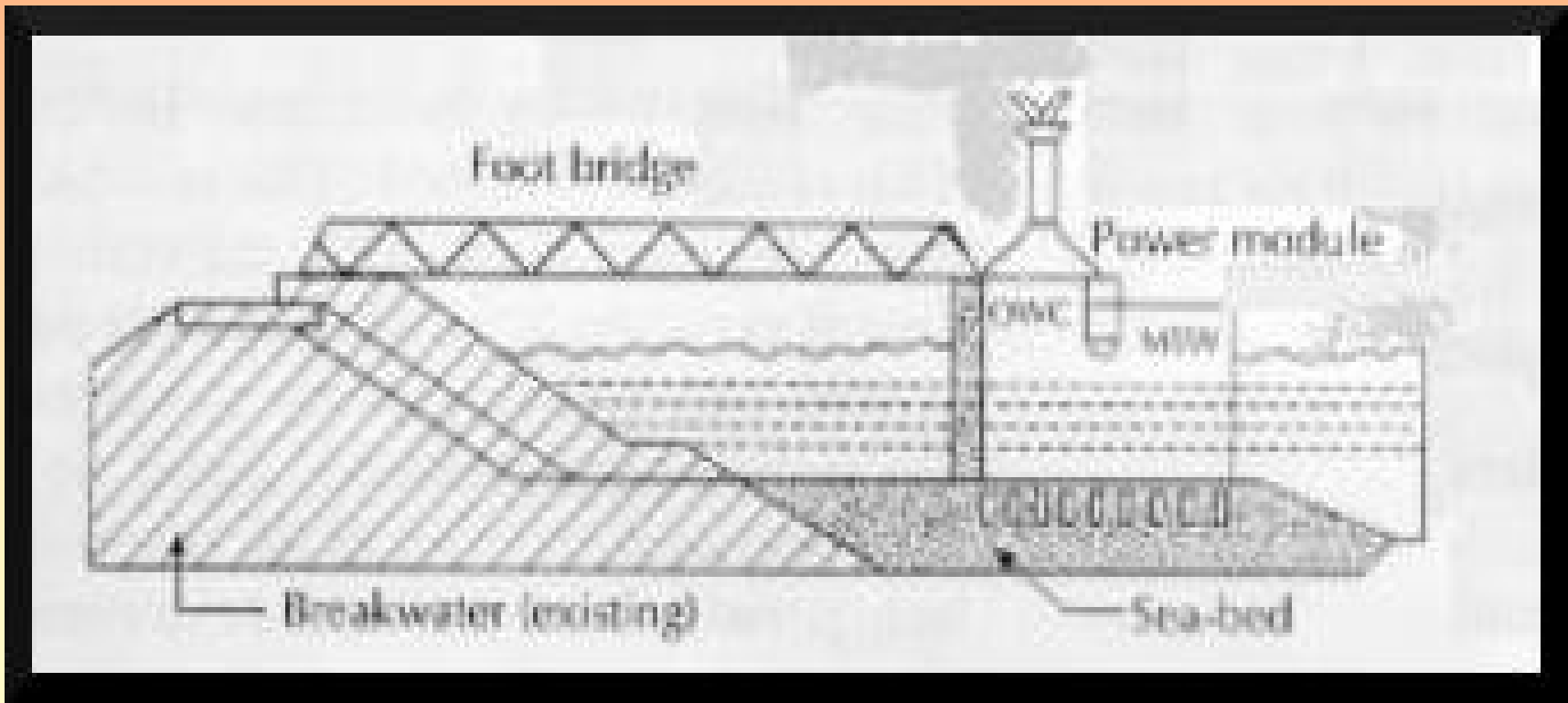

Design and installation of caisson-3

- The prototype turbine design specifications were as follows:

a) Type	Constant chord, wells
b) Profile	NACA 0021
c) Chord	380 mm
d) No. of rotor blades	8
e) Hub/tip ratio	0.6
- The turbine was coupled directly to a 110 kW squirrel cage induction generator with a rated speed of 1000 rotations per minute (rpm) and slip of eight per cent.
- The generator was connected to the shore transformer through a 600 m long cable, which runs along the breakwater up to its tip and along the bridge to the power module.

Design and installation of caisson-4

- The plant was first commissioned in October 1991.
- On evaluation of the plant operation data several areas for improvement were noted.
- The power module designed for a peak power of 150 kW had large no load losses and windage losses amounting to almost 15 kW.
- When the instantaneous wave power was low the turbine could not meet even the no-load losses.
- Hence, the system would motor, drawing power from the grid.
- This resulted in poor long-term efficiency of the wave power plant.

Design and installation of caisson-5

- several improvements were incorporated in the new module given below:
 - a) A tapered chord design was chosen for the turbine blades, as opposed to the earlier constant chord design.
 - b) Since the wave power is very high during monsoon and relatively low during off-monsoon months.
 - c) two horizontal axis thrust opposing turbine rotors were coupled to an electrical generator on a common shaft.
 - d) each having peak installed capacity of 55 kW.
 - e) The rationale behind this was that one module would be run during non-monsoon times and both during the peak season.
 - f) The electrical generator was a slip-ring induction machine in lieu of the earlier squirrel cage machine.

Efficiency Of The System

- The theoretical maximum conversion efficiency of the caisson (wave to pneumatic) at any given period (frequency) of the incoming wave is determined purely by its geometry.
- The direction of the wave, and an optimum value of the 'damping' on the caisson.
- In this case the turbine and the generator determine the damping.
- This value of the optimum damping is frequency dependent.
- Thus, the conversion efficiency of the caisson under operating conditions is governed by the load characteristics.
- The maximum average capacity of the caisson is estimated to be in excess of 240 kW under optimum load conditions.

Efficiency Of The System-1

- This estimate is based on the average monsoon input wave condition of 20 kW/m, 10 m caisson opening, and an average capture factor of 1.2 over the frequency range of interest.
- Almost two hundred runs were made under varying wave climates with various combinations of external resistances and butterfly valve positions in order to characterize their influence on plant performance.
- The efficiencies of the various subcomponents of the power plant as a function of incident wave power as measured during its operation from April 1996 to July 1996 are shown in Figure.

Efficiency Of The System-2

- The trends shown represent average values of several runs.
- A drop in efficiency for increasing incident energy is plainly evident.
- It is noted here that the nine-month average value of the incident wave power is 10 kW/m and peak monsoon average is 20 kW/m.
- From the analysis of 184 data sets, for a single module of 55 kW (peak) capacity, the mean caisson efficiency is 0.5 with standard deviation 0.2, the mean mechanical efficiency is 0.25 with standard deviation 0.09, and the mean electrical efficiency is 0.5 with standard deviation 0.08.
- The mean overall efficiency is 0.06 with standard deviation 0.02.

Efficiency Of The System-3

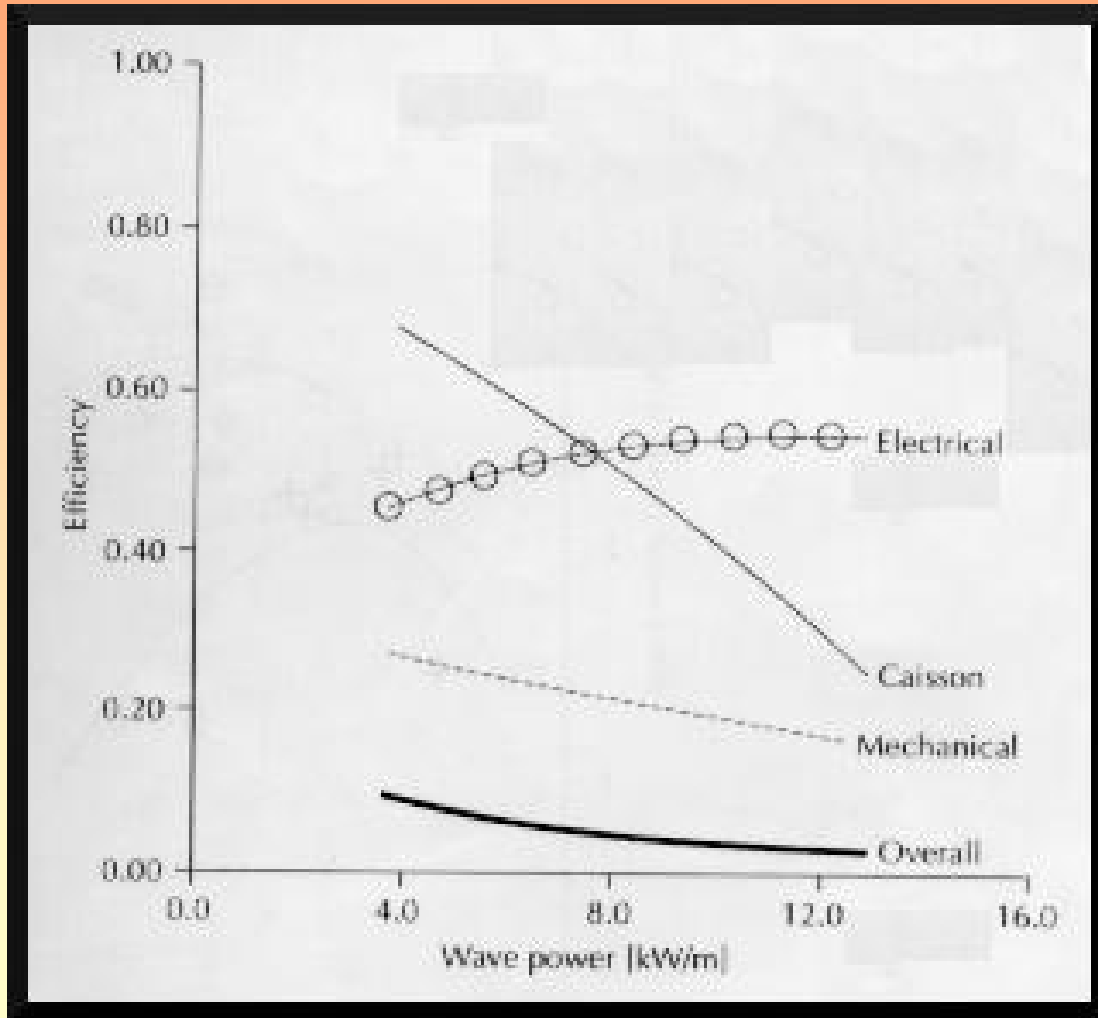

Environmental Impacts

- Wave energy converters (WEC's) have effects on the adjacent coastline even though they are out at sea
 - a) Wave Distortion
- WEC's have the effect of significantly lengthening the wavelength and reducing the height of the waves, which pass through them.
- In fact, calculations taken in force seven storm conditions showed wave heights reduced from 5.9m to 4.6m while the wavelength increased from 8.4s to 9.0s.
- This results in coastlines being less affected by the erosion, typical of short, steep waves, and more affected by the building up of debris caused by long, shallow waves.

Environmental Impacts-1

- This ‘side effect’ is seen as beneficial in some areas, for example North and South Uist and Benbecula in the Outer Hebrides.
- This is because the increased amount of sediment on the beaches reduces the impact of storm waves on the shore, and the communities near the shore.
- However this effect may not be seen as beneficial to other coastlines, and so must be considered carefully.

Environmental impacts-2

The eyesore factor:

- Although WEC's are typically large and can be unsightly,
- It is unlikely that they will be visible from the shore, as they are usually far enough out at sea to be invisible to the naked eye.
- The only 'eyesores' created would be the reception terminal (but if managed correctly could be made to be aesthetically pleasing through landscaping) and the overhead power lines which would be required to transport the power.
- In the case of Scotland these cables would have to be routed through areas of considerable scenic beauty.

Environmental Impacts-3

Effects on the Ecology of the area:

- As well as affecting the waves, WEC's can alter ocean surface currents.
- This will have no effect on benthic dwelling fish, but the many species of fish in the surface waters (e.g. salmon) which depend on currents to navigate between spawning and feeding grounds, could experience difficulties completing their life cycles which could not only affect the ecosystem but the fishing industry as well.
- This could be minimized by ensuring that WEC's are positioned in places in which the sea life in the ocean surface is well researched and understood, and that WEC numbers or size do not adversely contribute to the distortion of surface currents.

Environmental Impacts-4

Effects on shipping and navigation:

- The risk of collision with WEC's is the primary hazard to shipping due to their design making them difficult to detect by both eye and by radar.
- For this reason warning lights and clearly marked channels to ensure the safe navigation around converters are essential.
- To a great extent all shipping would have to be excluded from the immediate vicinity of the devices.
- This will have varying levels of interference depending on the location of a WEC.
- These effects on shipping will have consequences for the fishing industry as boats may be excluded from prime fishing grounds.