

Operating Principle

History

- In 1839 Edmond Becquerel accidentally discovered photovoltaic effect when he was working on solid-state physics.
- In 1878 Adam and Day presented a paper on photovoltaic effect.
- In 1883 Fxitz fabricated the first thin film solar cell.
- In 1941 ohl fabricated silicon PV cell but that was very inefficient.
- In 1954 Bell labs Chopin, Fuller, Pearson fabricated PV cell with efficiency of 6%.
- In 1958 PV cell was used as a backup power source in satellite Vanguard-1. This extended the life of satellite for about 6 years.

Photovoltaic Cell

- A photovoltaic cell is the basic device that converts solar radiation into electricity.
- It consists of a very thick n-type crystal covered by a thin n-type layer exposed to the sun light as shown in the following figure:

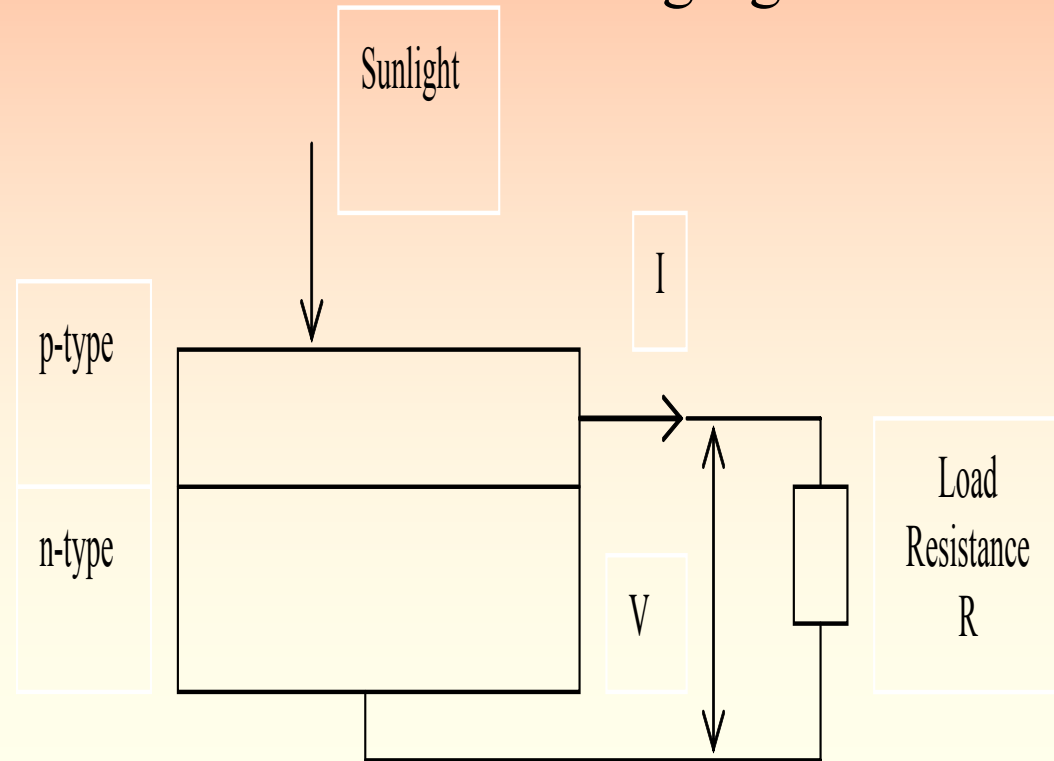
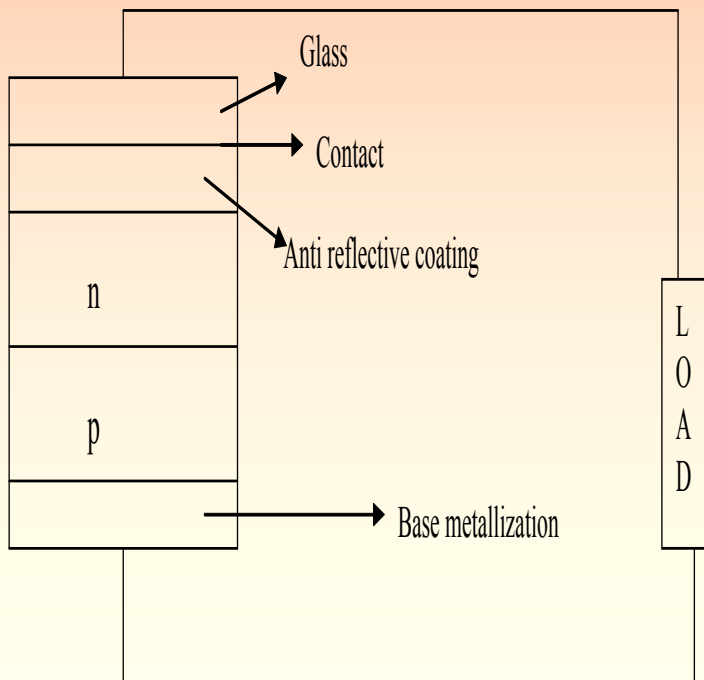

Photovoltaic Cell-1

- A PV cell can be either circular in construction or square.

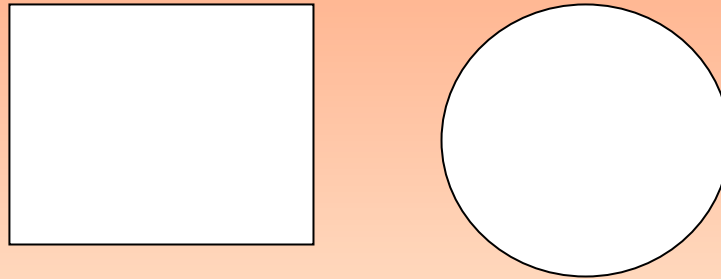

- Cells are arranged in a frame to form a module. Modules put together form a panel.
- Panels form an array.
- Each PV cell is rated for 0.5 – 0.7 volt and a current of 30mA/cm².

Photovoltaic Cell-2

- Based on the manufacturing process they are classified as:
- Poly crystalline: efficiency of 12%.
- Amorphous: efficiency of 6-8% .
- Life of crystalline cells is in the range of 25 years where as for amorphous cells it is in the range of 5 years.

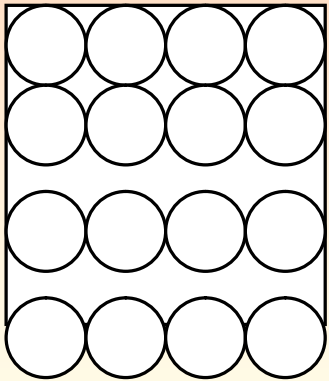

PV module

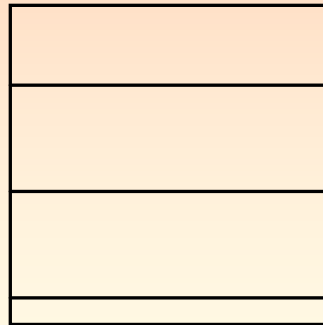

PV panel

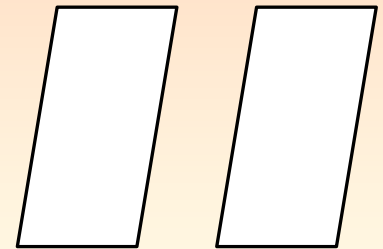

Array

Photovoltaic Cell-3

Equivalent circuit of PV cell:

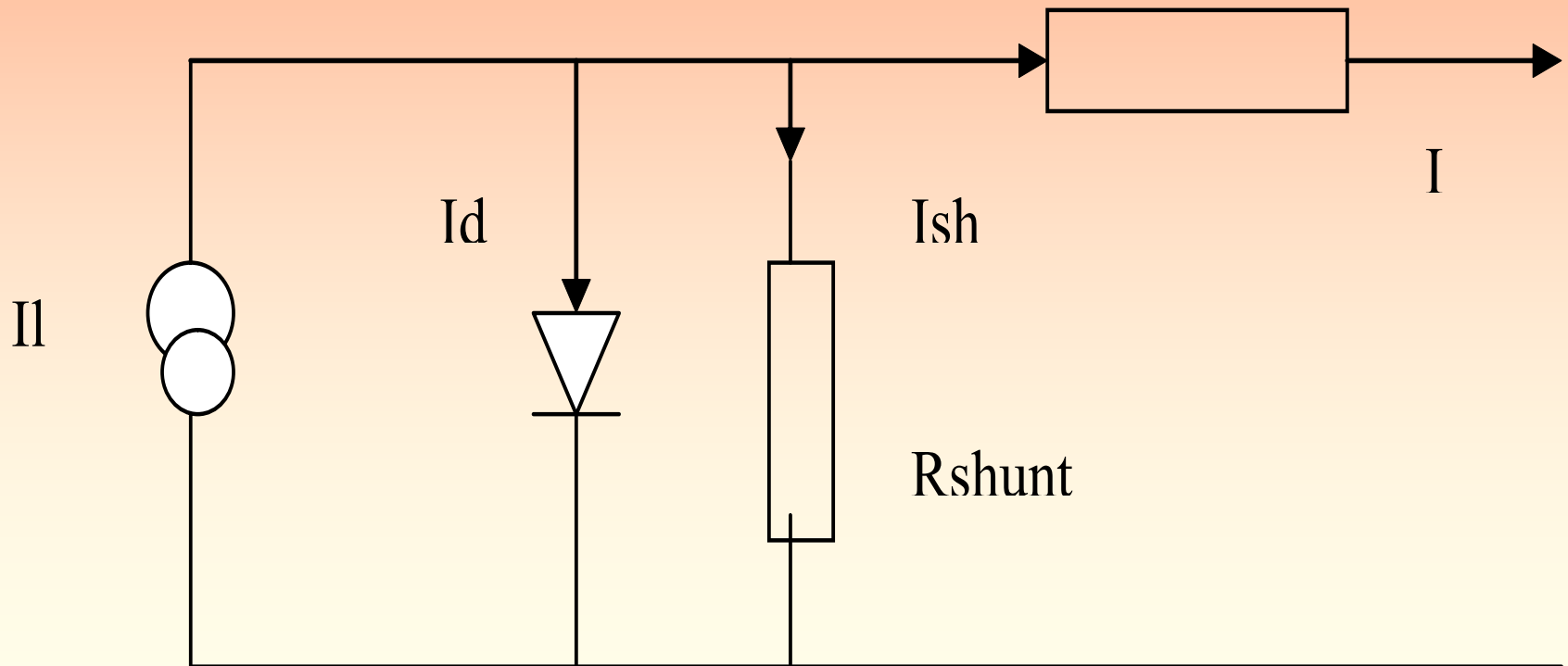

Photovoltaic Cell-4

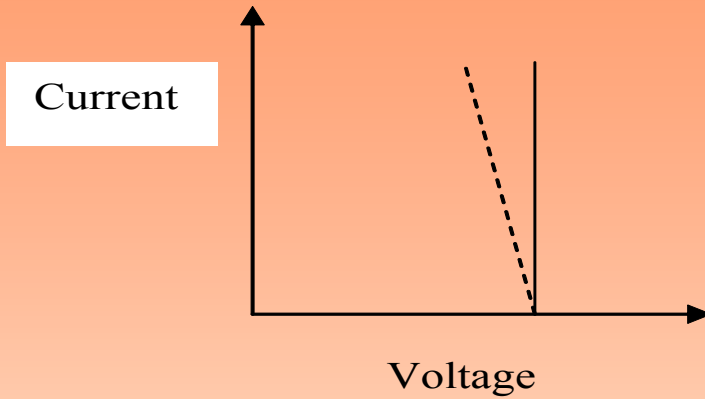

Constant voltage source

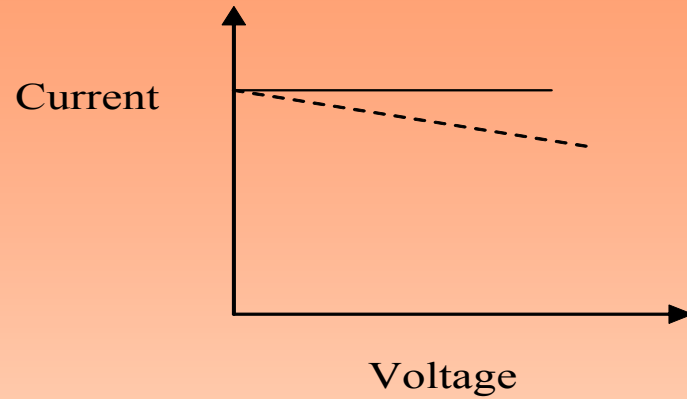

Constant current source

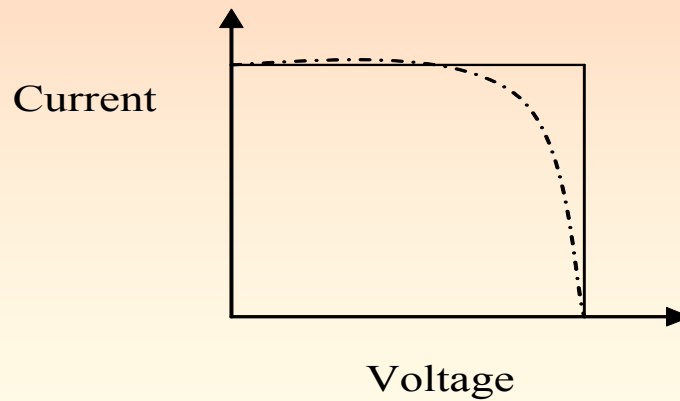

Characteristics of photovoltaic cell

Photovoltaic Cell-5

Symbol of PV cell:

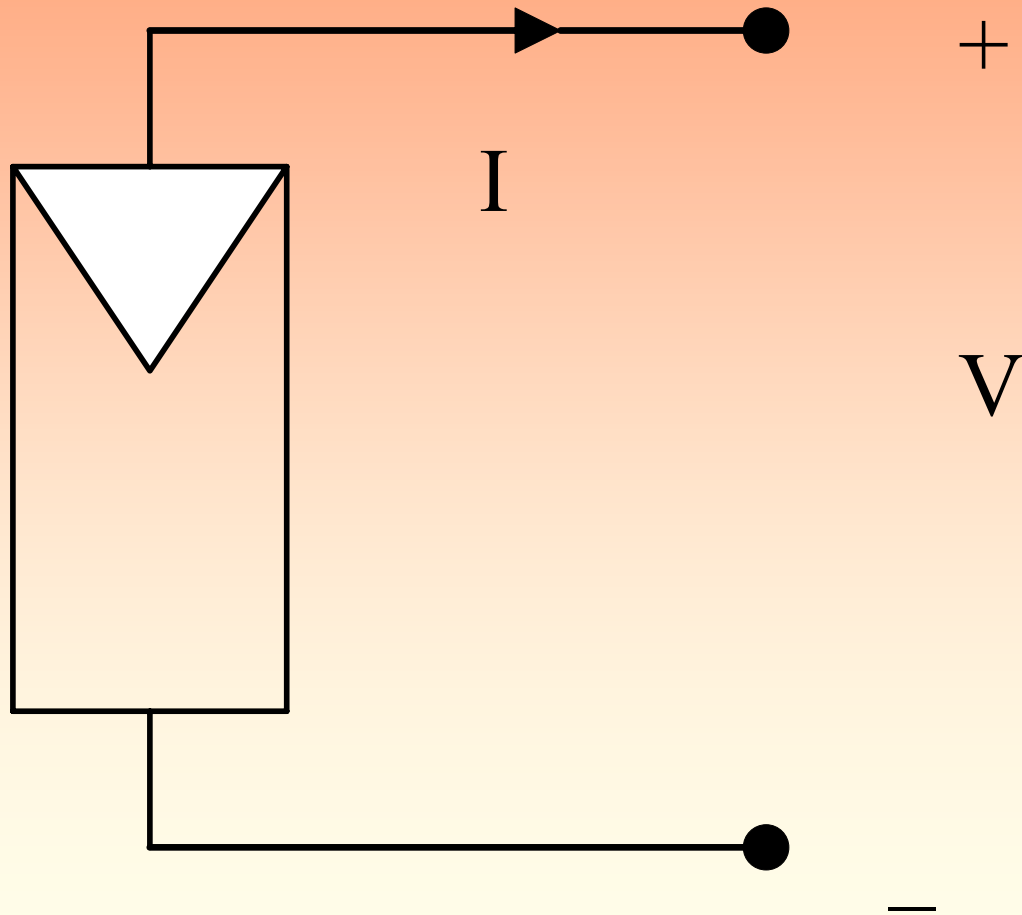

PV Module I-V Characteristics

Terminology:

- **Solar Cell:** The smallest, basic Photovoltaic device that generates electricity when exposed to light.
- **PV Module:** Series and parallel connected solar cells (normally of 36Wp rating).
- **PV Array:** Series and parallel connected PV modules (generally consisting of 5 modules).
- A solar cell delivers different amount of current depending on the irradiation (or insolation) to the cell, the cell temperature and where on the current-voltage curve the cell is operated.

PV Module I-V Characteristics-1

- A PV cell behaves differently depending on the size/type of load connected to it.
- This behaviour is called the PV cell 'characteristics'.
- The characteristic of a PV cell is described by the current and voltage levels when different loads are connected.
- When the cell is not connected to any load there is no current flowing and the voltage across the PV cell reaches its maximum. This is called 'open circuit' voltage.
- When a load is connected to the PV cell current flows through the circuit and the voltage goes down.
- The current is maximum when the two terminals are directly connected with each other and the voltage is zero. The current in this case is called 'short circuit' current.

PV Module I-V Characteristics-2

Experimental Setup

- There are two ways of measuring the characteristics of the PV module, via is,
- Noting down each operating point on the characteristics by varying the load resistance. The setup is as shown in Fig 1.
- Applying a varying signal (sinusoidal) to the cell and observing the characteristics in the XY mode of the oscilloscope.
- One of the requirements in the second method is that the variable source should have the sinking capability.

PV Module I-V Characteristics-3

- The disadvantage with this setup is the application of the negative supply to the cell.
- The cell is protected by an anti-parallel diode and if a large negative voltage is applied then diode may fail resulting in failure of the solar cell also.
- This reverse breakdown region of operation was observed on the scope.

PV Module I-V Characteristics-4

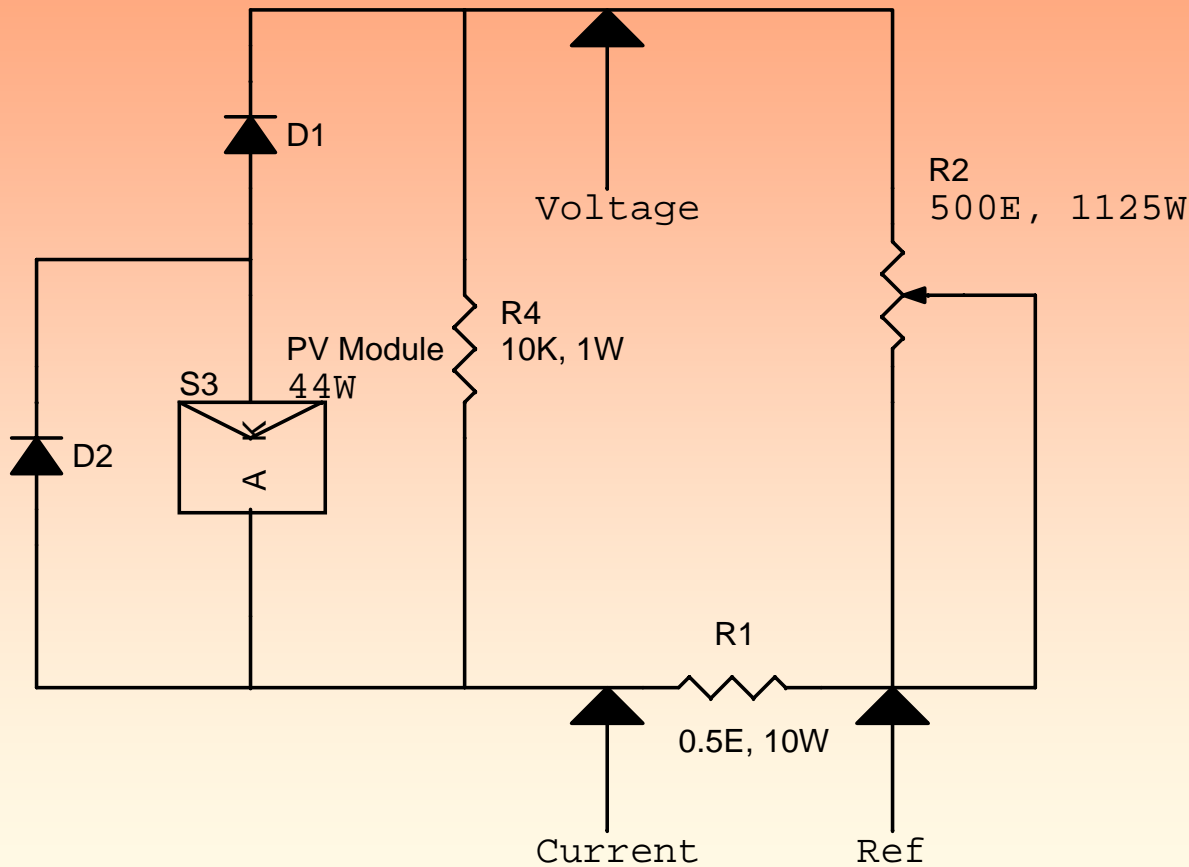

Fig 1: Circuit configuration for measuring the discrete points on PV characteristics.

PV Module I-V Characteristics-5

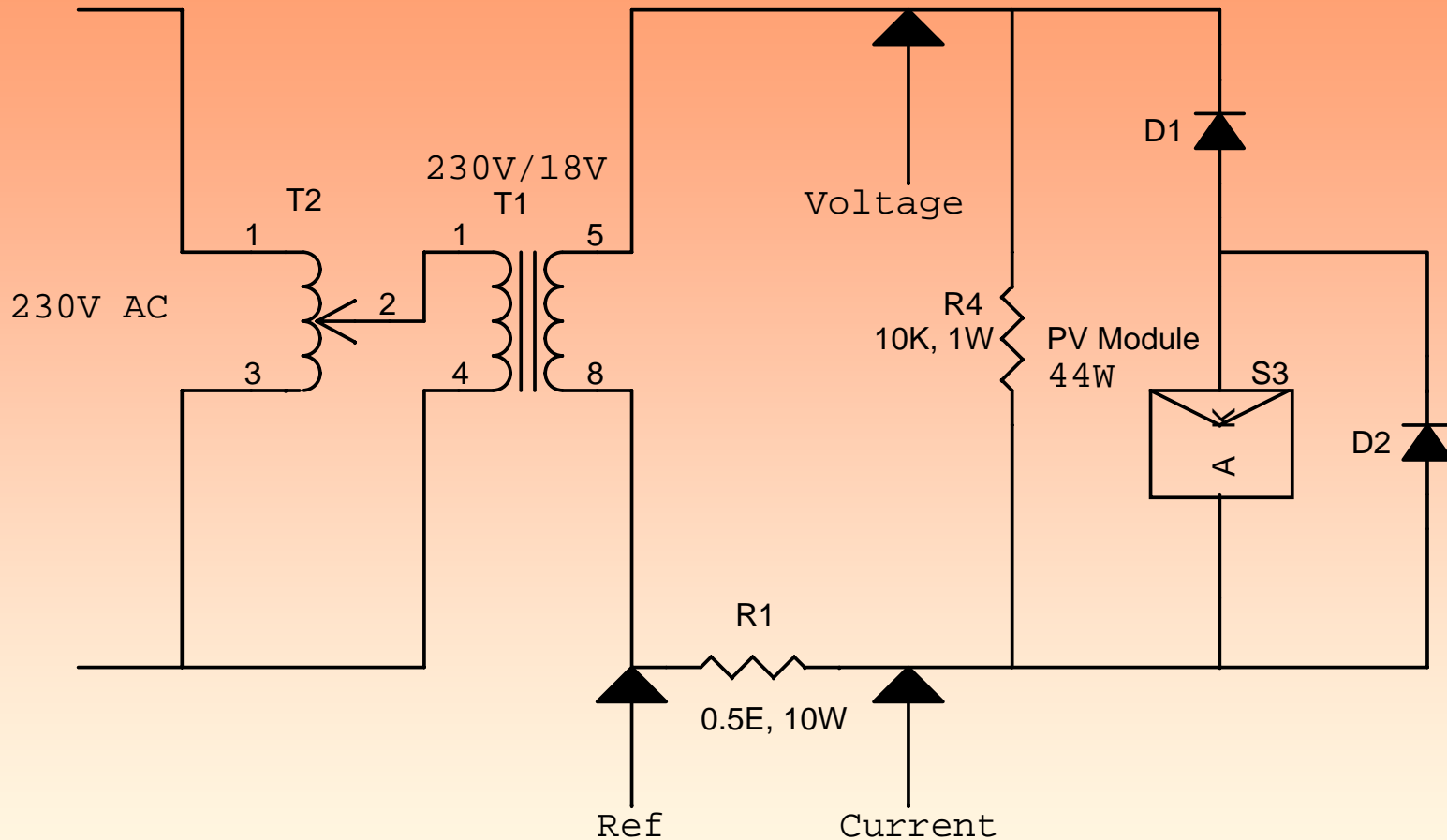

Fig 2: Circuit configuration for measuring the on PV characteristics on scope (disadvantage – operating the diodes D1 and D2 in reverse biased mode resulting in large reverse current).

PV Module I-V Characteristics-6

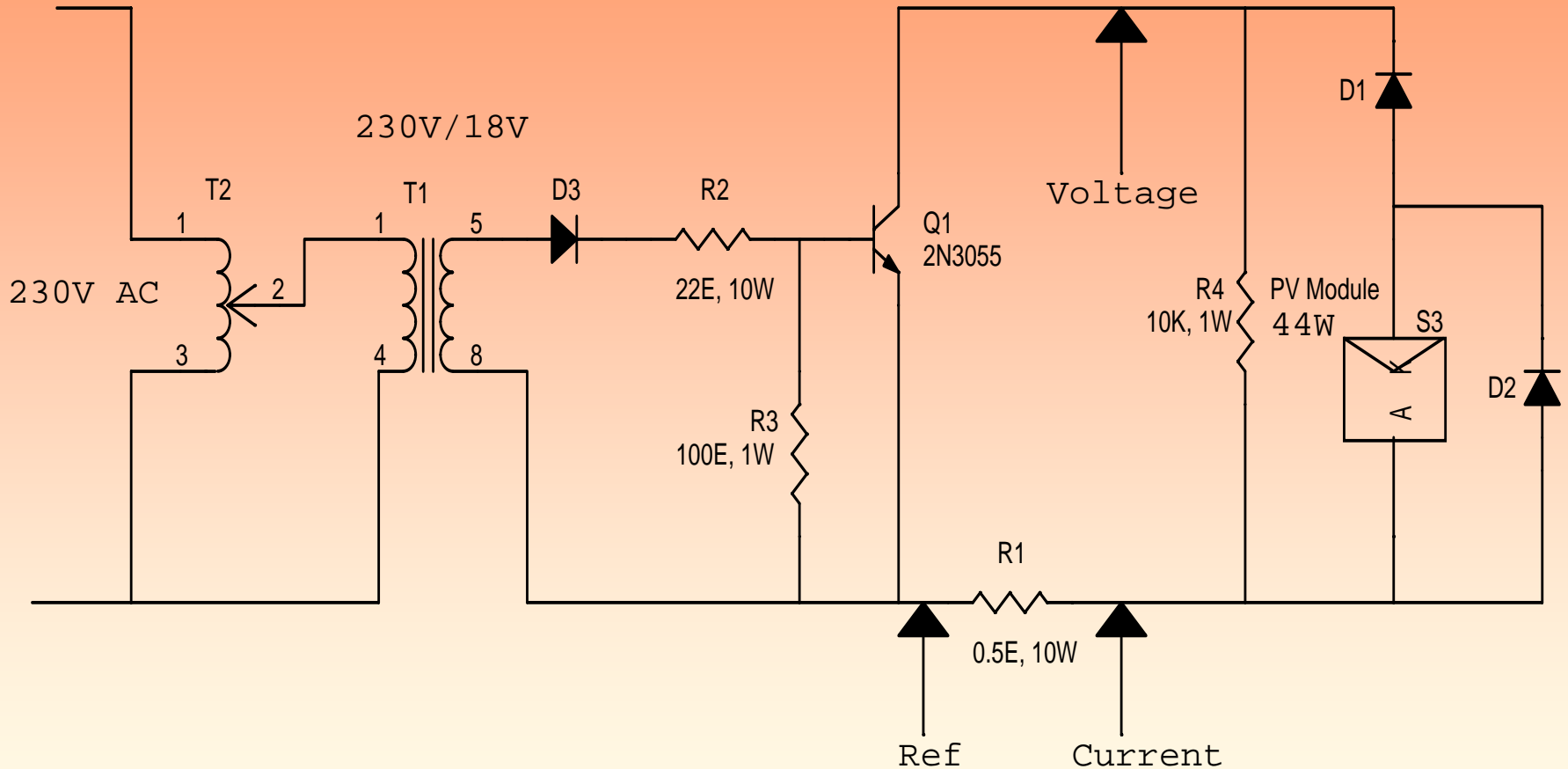
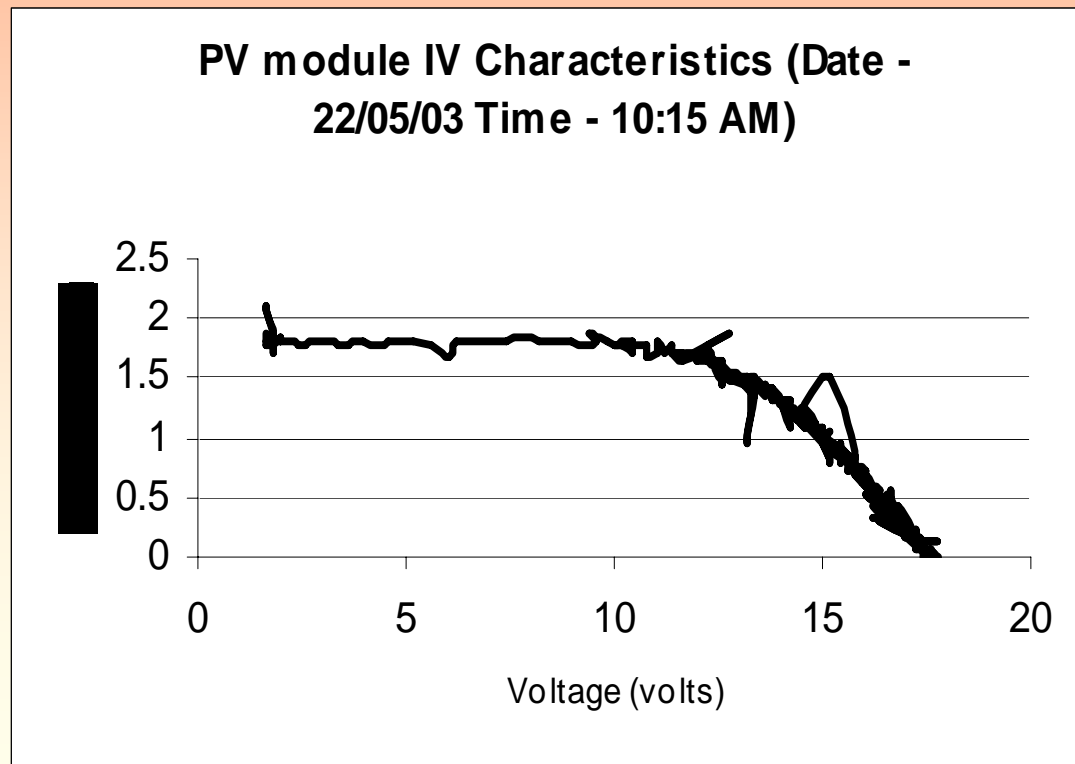

Fig 3: Experimental setup for measuring the PV module characteristics.

PV Module I-V Characteristics-7

Waveforms:

- Below are the PV module IV characteristics taken at different time instances of the day with the experimental setup shown in Fig 3



PV Module I-V Characteristics-8

Waveforms:

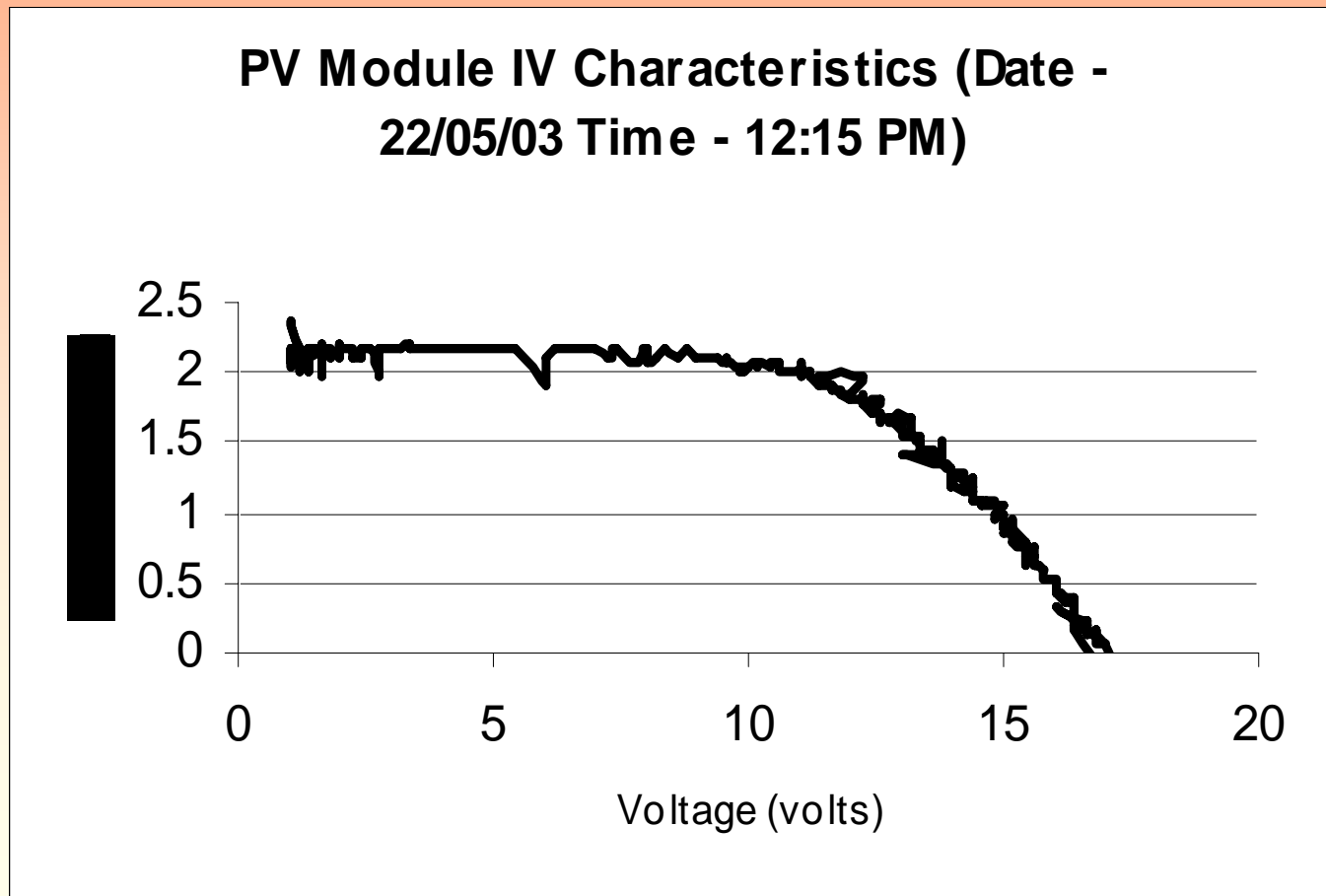

PV Module I-V Characteristics-9

Waveforms:

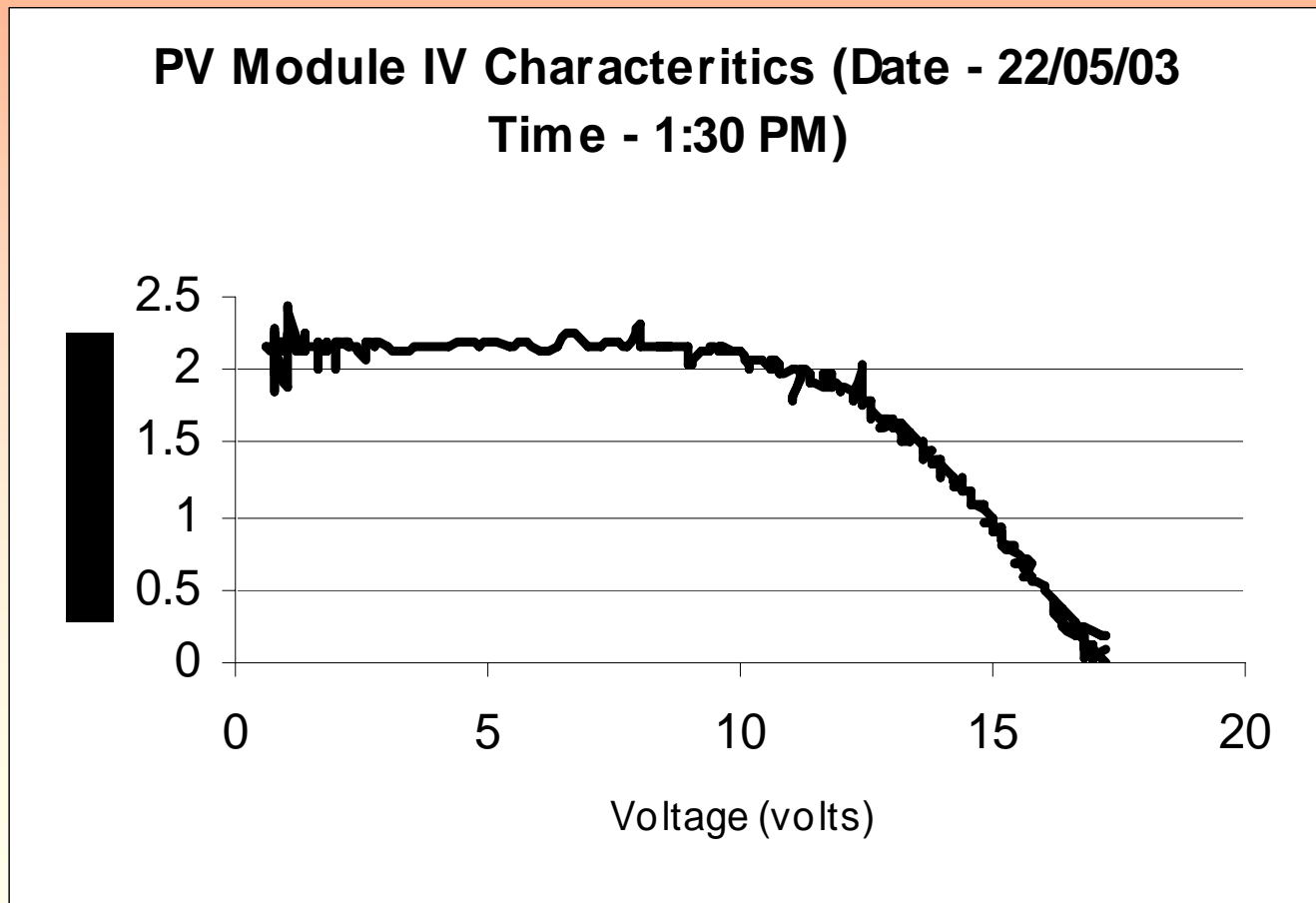

PV Module I-V Characteristics-10

Waveforms:

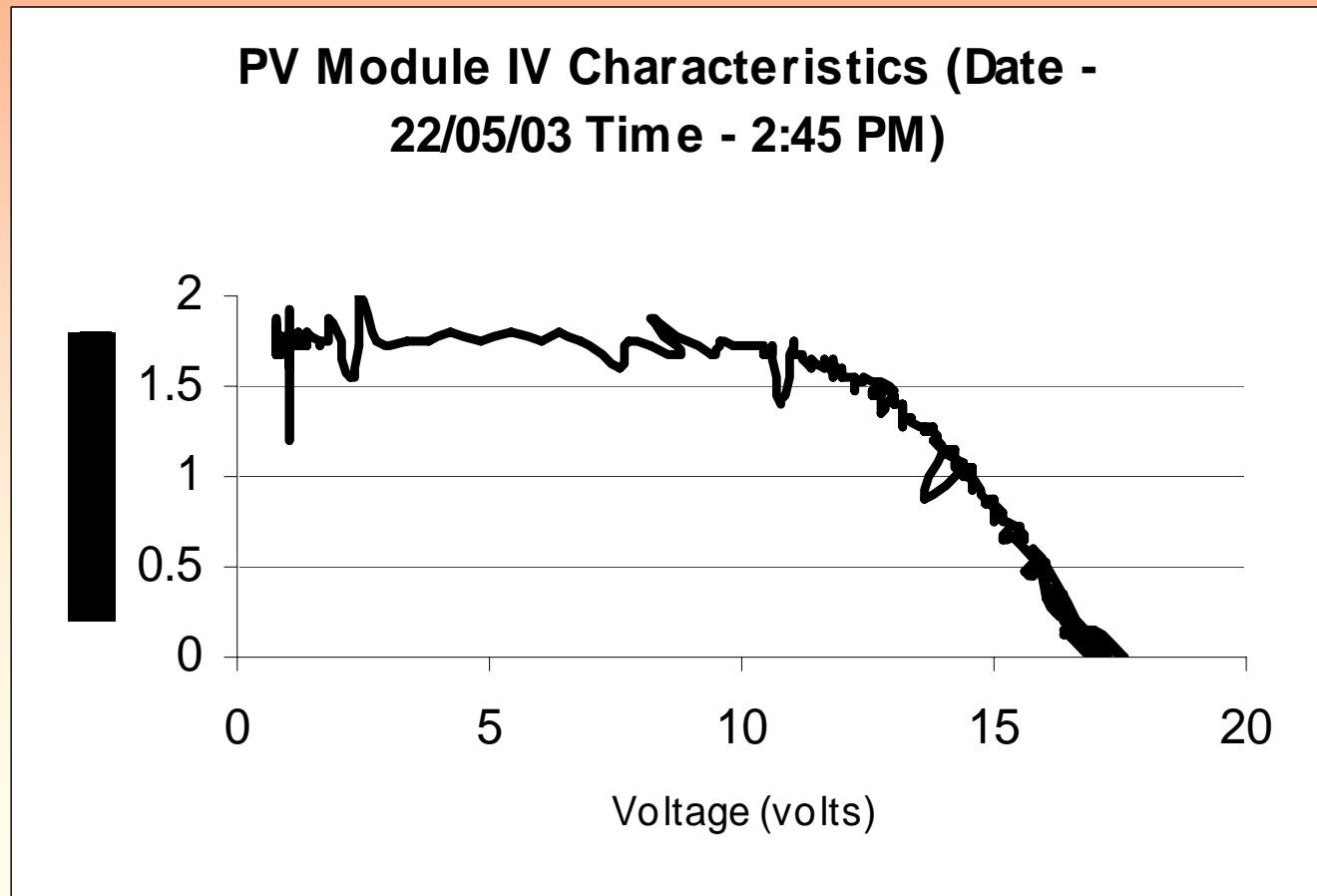

PV Module I-V Characteristics-11

Waveforms:

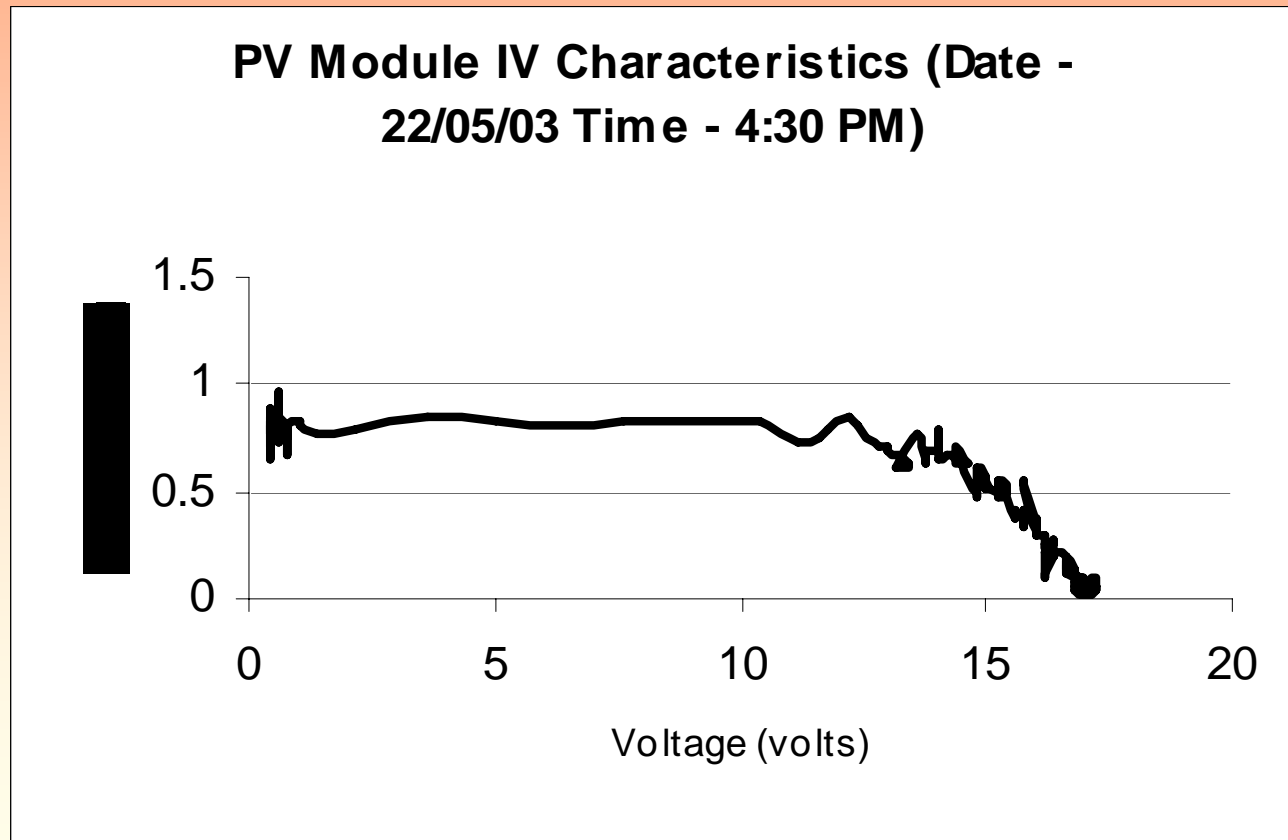

PV Module I-V Characteristics-12

The PV characteristics as measured by the experiment setup shown in Fig

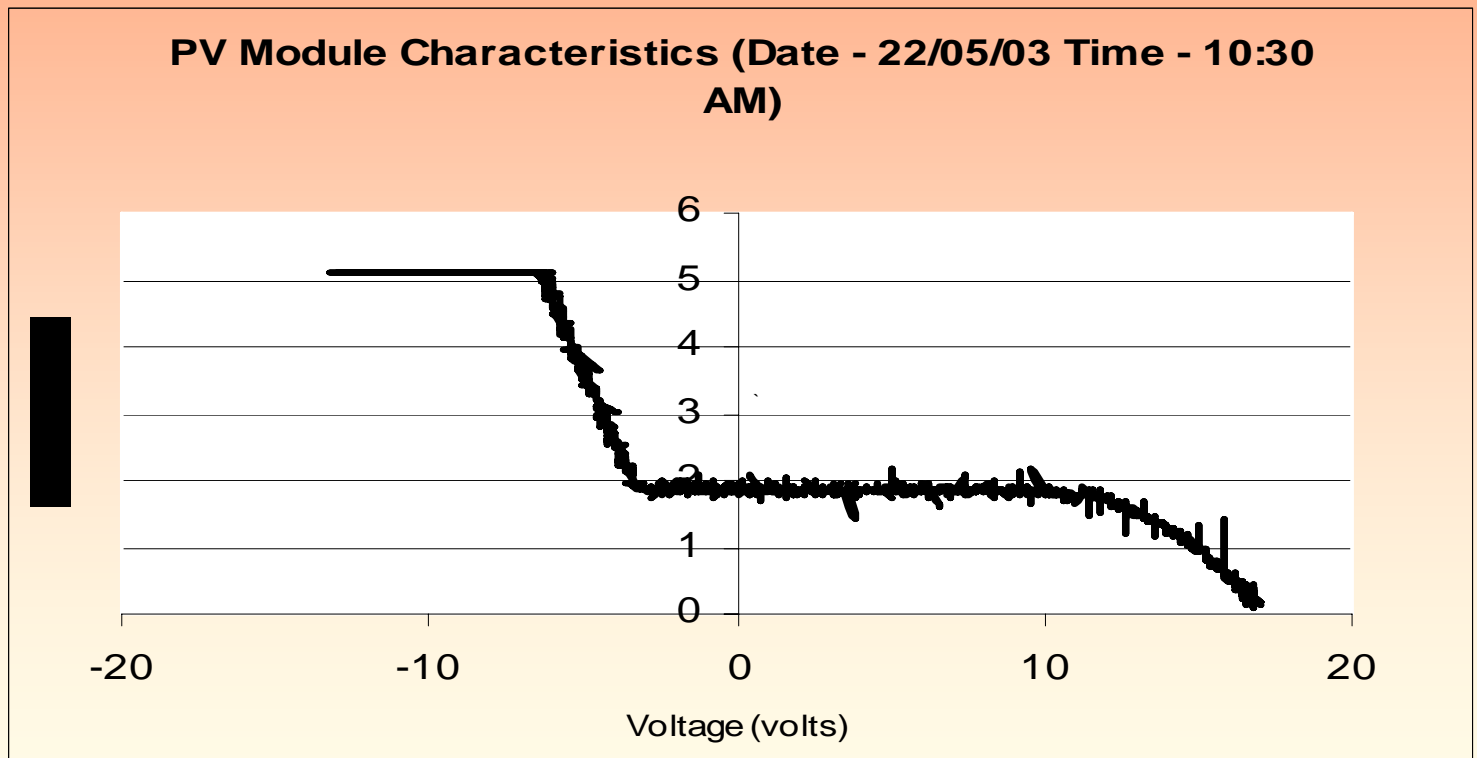

PV module IV characteristics as measured for setup shown in Fig

PV Module I-V Characteristics-13

Inferences:

- The PV module power varies depending on the insolation and load (operating point). So it is very much necessary to operate the PV at its maximum power point.
- The PV module short-circuit current is directly proportional to the insolation.
- The solar cell operates in two regions, that is, constant voltage and constant current. So it can be modeled as shown in Fig

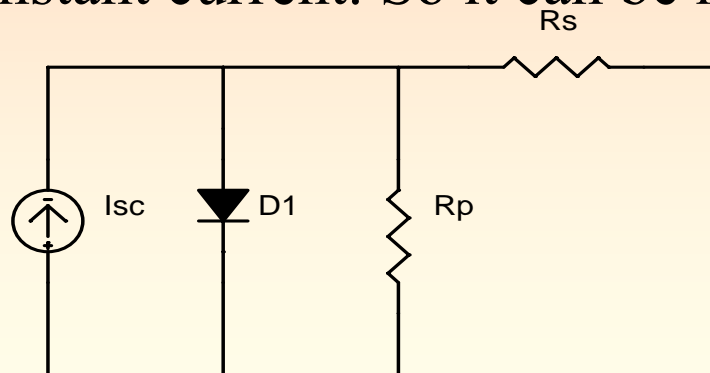

Solar Cell model

PV Module I-V Characteristics-14

- Resistance R_p decides the slope of the characteristics in the constant current region.
- Resistance R_s decides the slope of the characteristics in the constant voltage region.

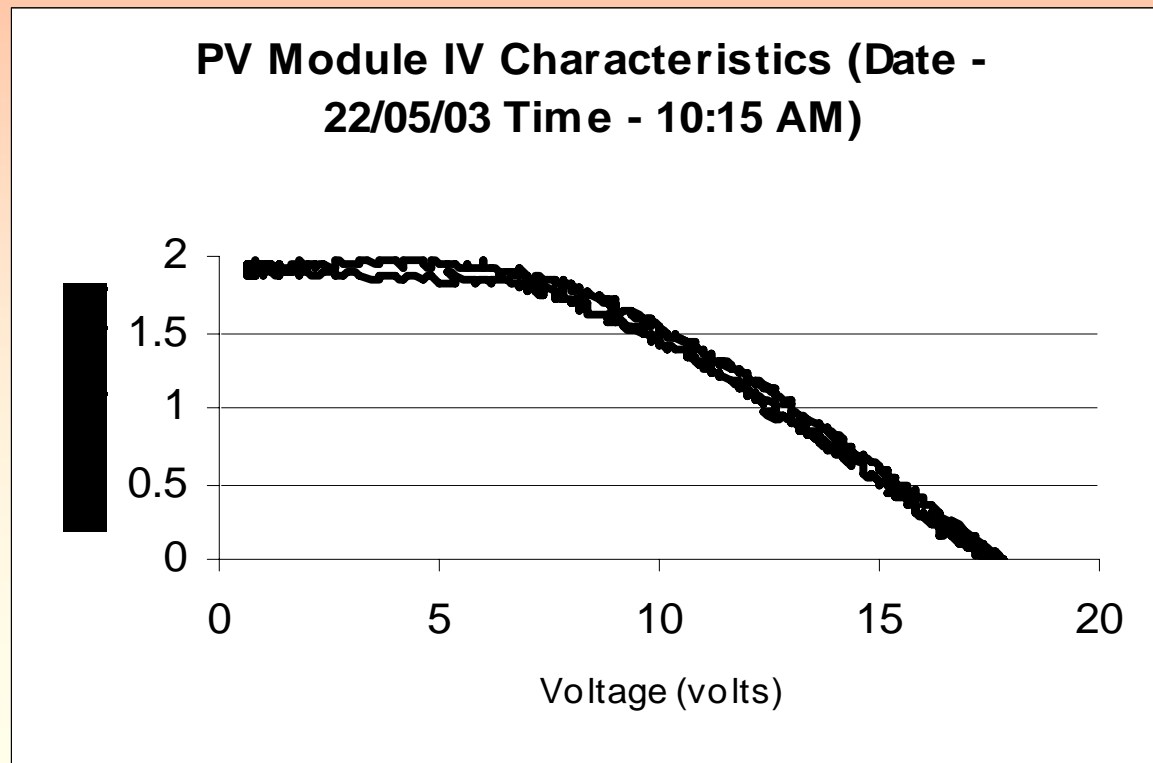

PV Module I-V Characteristics-15

- PV module characteristics measured with $R1 = 3.5 \text{ E}$ in Fig 3. There is a decrease in slope in the constant voltage region of the characteristics.
- There is also a low pass (hysteresis) effect observed in Figure.
- This is due to the different switching characteristics during ON and OFF instance of the transistor.

PV Cell concepts

- Several mathematical models exist representing a PV cell.
- One of the simplest models that represents PV cell to satisfaction is shown in the following figure:

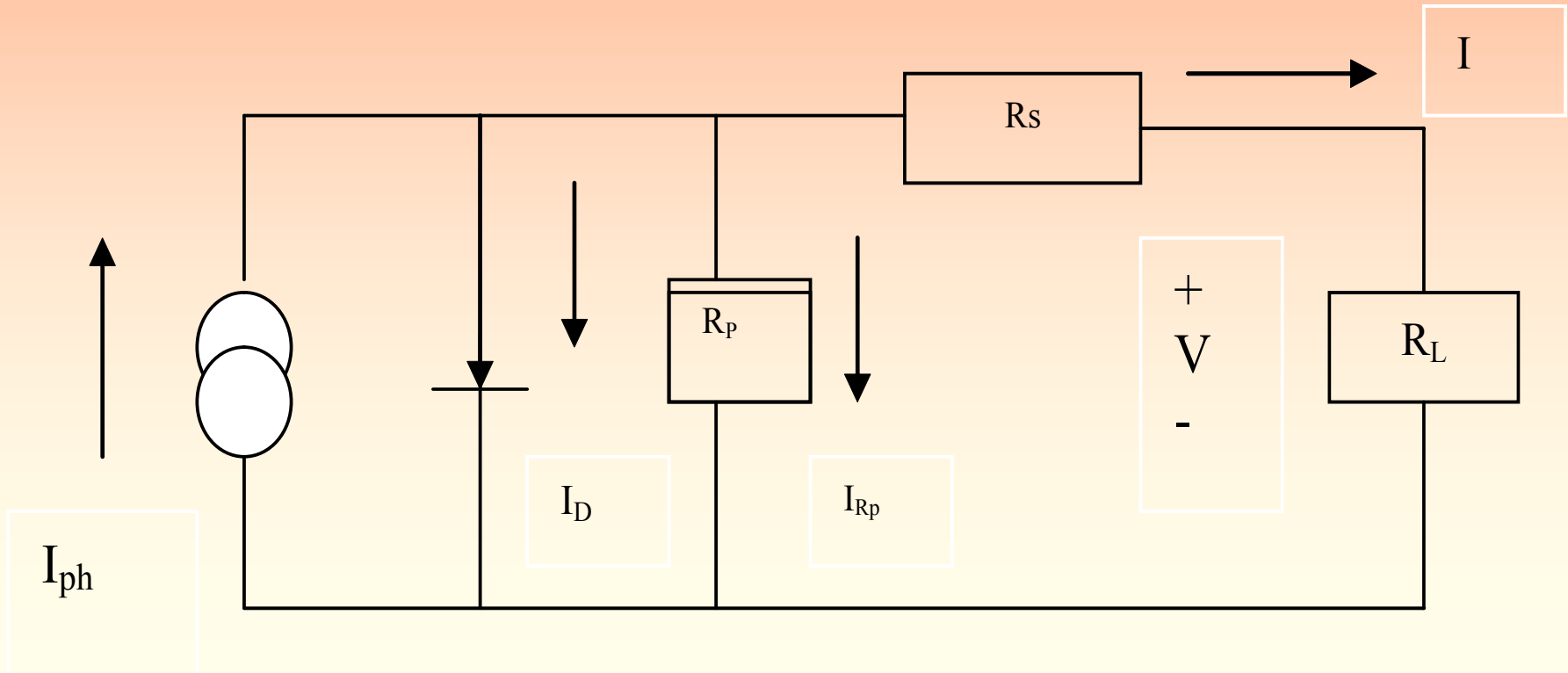

PV Cell concepts-1

- Applying Kirchoff's current law to the node where I_{ph} , diode, R_p and R_s meet, we get the following equation:

$$I_{ph} = I_D + I_{Rp} + I$$

- We get the following expression for the photovoltaic current from the above equation:

$$I = I_{ph} - I_D - I_{Rp}$$

$$I = I_{ph} - I_o \cdot \left[\exp\left(\frac{V + I \cdot R_s}{V_T}\right) - 1 \right] - \left[\frac{V + I \cdot R_s}{R_p} \right]$$

PV Cell concepts-2

where,

- I_{ph} = Insolation current
- I = Cell current
- I_0 = Reverse saturation current
- V = Cell voltage
- R_s = Series resistance
- R_p = Parallel resistance
- V_T = Thermal voltage = KT/q
- K = Boltzman constant
- T = Temperature in Kelvin
- q = charge of an electron

PV Cell concepts-3

- V-I characteristics of the cell would look as shown in the following figure:

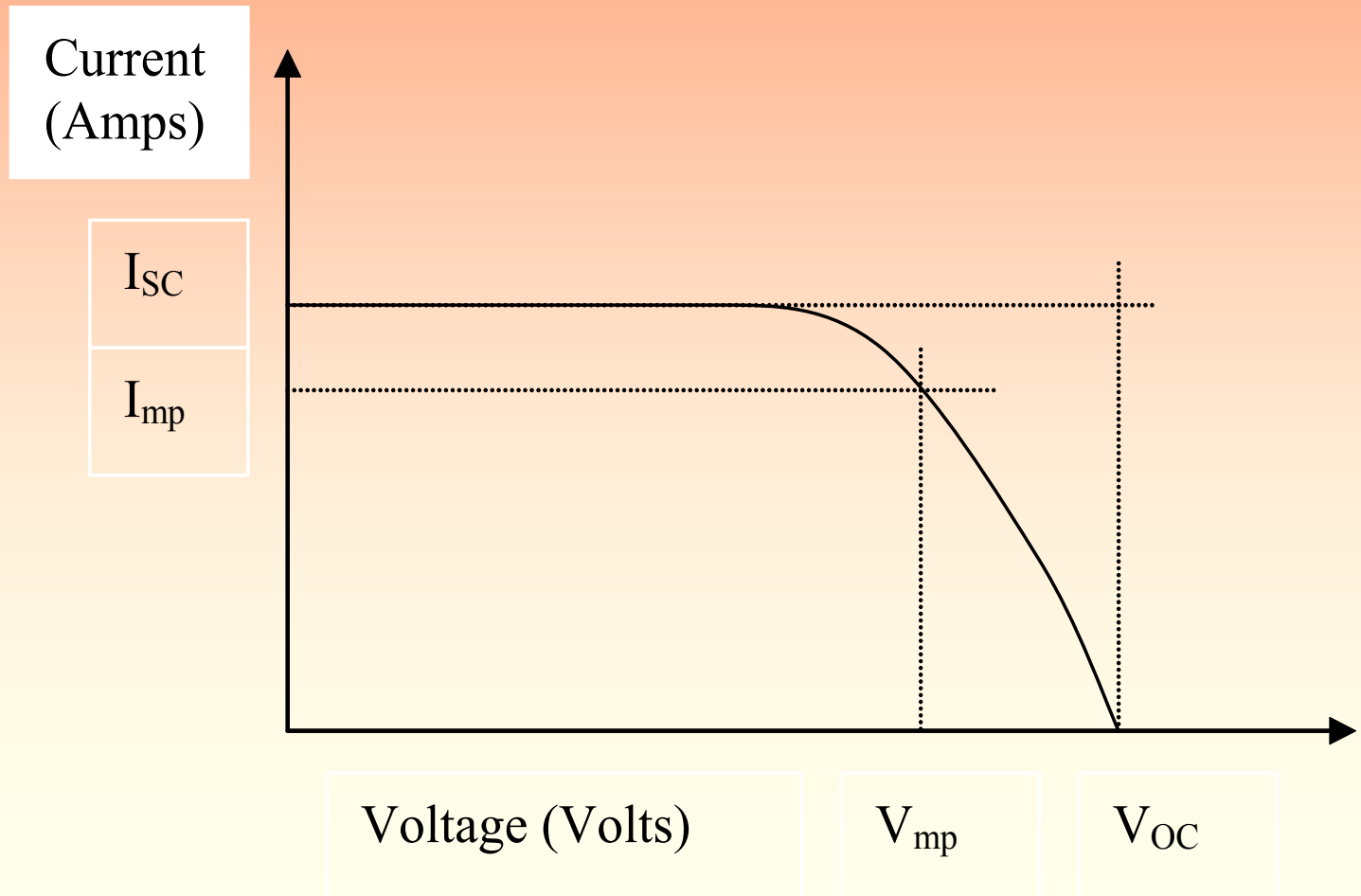

PV Cell concepts-4

- Let us try to look at the characteristic curve closely and define two of the points.
- First one is the short circuit current I_{SC} and the second one is the open circuit voltage V_{OC} .
- Short circuit current is the current where the cell voltage is zero. Substituting $V = 0$ in equation 3, we get the following expression for the short circuit current:

$$I_{SC} = I_{ph} - I_o \cdot \left[\exp\left(\frac{I_{SC} \cdot R_s}{V_T}\right) - 1 \right] - \left[\frac{I_{SC} \cdot R_s}{R_p} \right]$$

PV Cell concepts-5

- We can see that for a given temperature, I_o and V_T are constants and hence the second term is almost a constant and the third term is also a constant.
- This implies that the short circuit current I_{SC} depends on I_{ph} , the insolation current. Mathematically we can write:

$$I_{SC} \propto I_{ph}$$

- Open circuit voltage is the voltage at which the cell current is zero.
- The expression for the open circuit voltage can be obtained by substituting $I = 0$ in equation 3 and simplifying. We obtain the following expression:

$$V_{OC} = V_T \cdot \ln \left[\frac{I_{ph}}{I_o} - \frac{V_{OC}}{I_o \cdot R_p} + 1 \right]$$

PV Cell concepts-6

- Again we see from the above expression that V_{OC} is a function of natural log of I_{ph} .
- V_{OC} increases with I_{ph} . Following figure explains the behavior of both I_{SC} and V_{OC} with the insolation level:

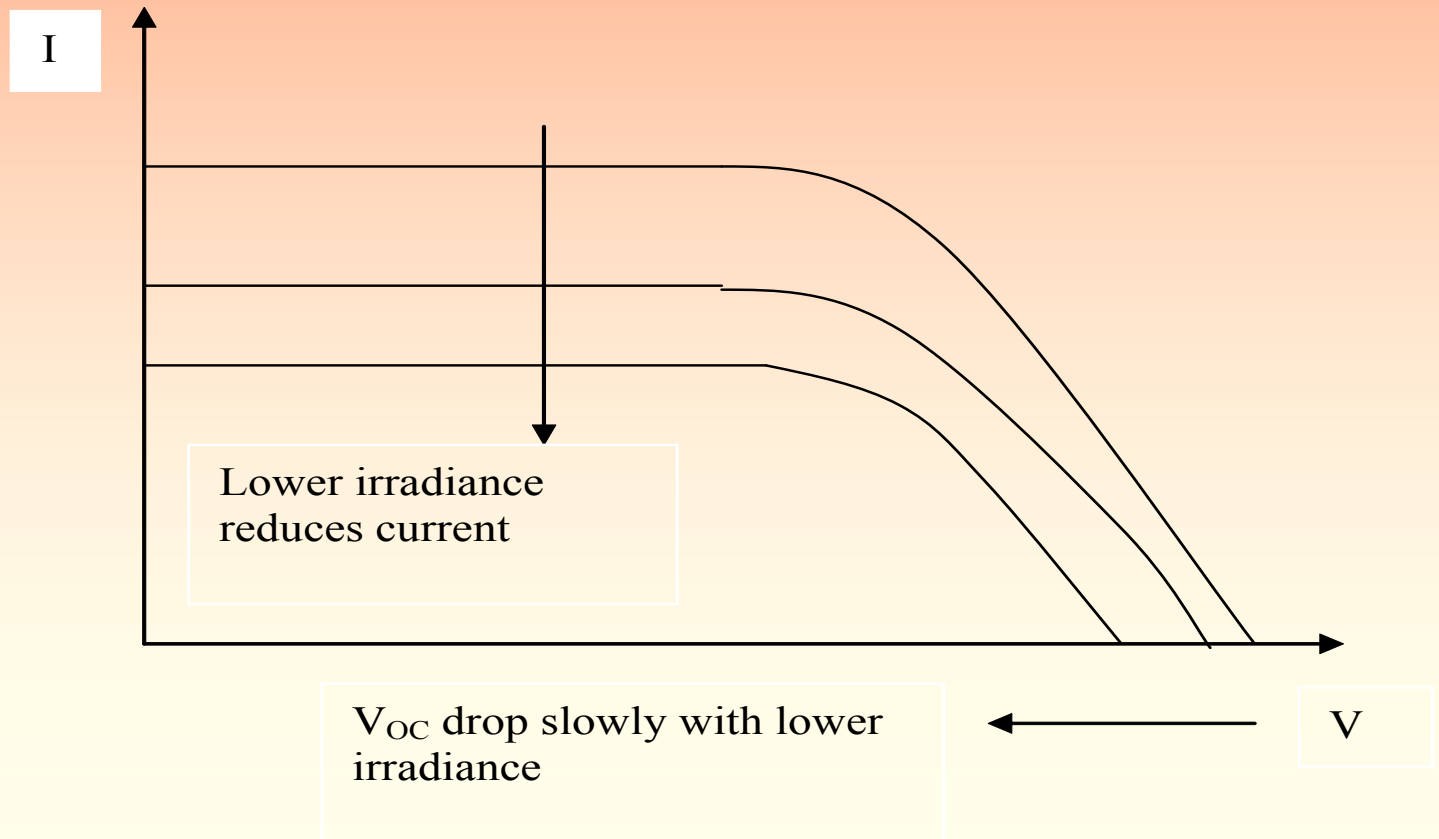

Efficiency of the cell

- The efficiency of the cell is defined as the ratio of Peak power to input solar power. It is given as:

$$\eta = \frac{V_{mp} \cdot I_{mp}}{I(kW / m^2) \cdot A(m^2)}$$

where A is the area of the cell and I is the Insolation.

Quality of cell

- Every cell has a life expectancy.
- As time progresses, the quality of cell goes down. Hence, it is essential to check the quality, periodically so that it can be discarded once the quality falls below certain level.
- To calculate the quality of a cell, let us consider the V-I characteristics of the cell shown earlier.
- In the figure, we had two more terms, I_{mp} and V_{mp} .

Quality of cell-1

- These are the current at maximum power and voltage at maximum power. Now knowing all the four quantities, V_{OC} , I_{SC} , V_{mp} and I_{mp} , the quality of the cell called Fill Factor (FF) can be calculated as follows:

$$FF = \frac{V_{mp} \cdot I_{mp}}{V_{OC} \cdot I_{SC}}$$

- Ideally, the fill factor should be 1 or 100%. However, the actual value of FF is about 0.8 or 80%.
- A graph of the FF vs the insolation gives a measure of the quality of the PV cell.

Quality of cell-2

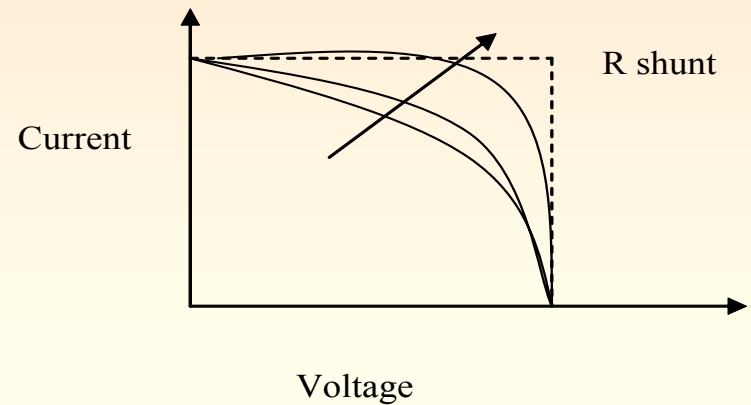
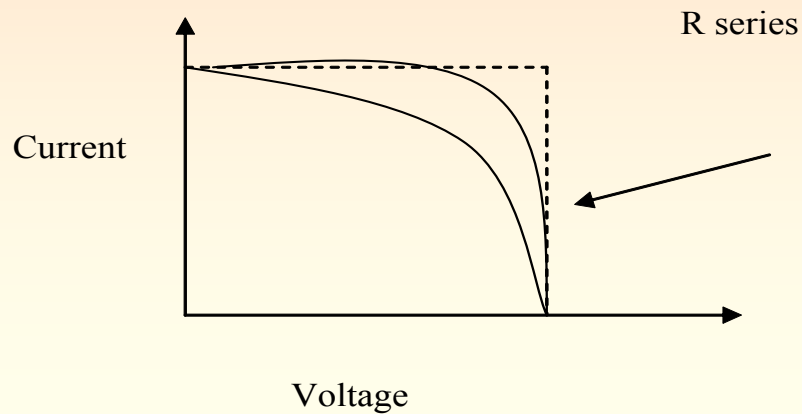
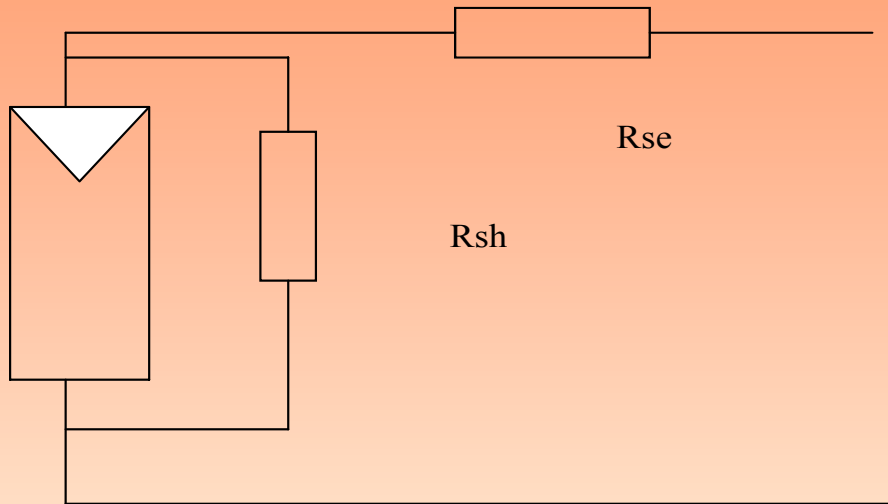

Quality of cell-3

- To find the quality of the solar panel fill factor is used .
- It is defined as $(V_{mp} * I_{mp}) / (V_{oc} * I_{sc})$.
- A good panel has fill factor in the range of 0.7 to 0.8. for a bad panel it may be as low as 0.4.
- V_{mp} , I_{mp} , V_{oc} , I_{sc} are defined as shown in figure.
- The variation fill factor with insolation is as shown in figure 2.

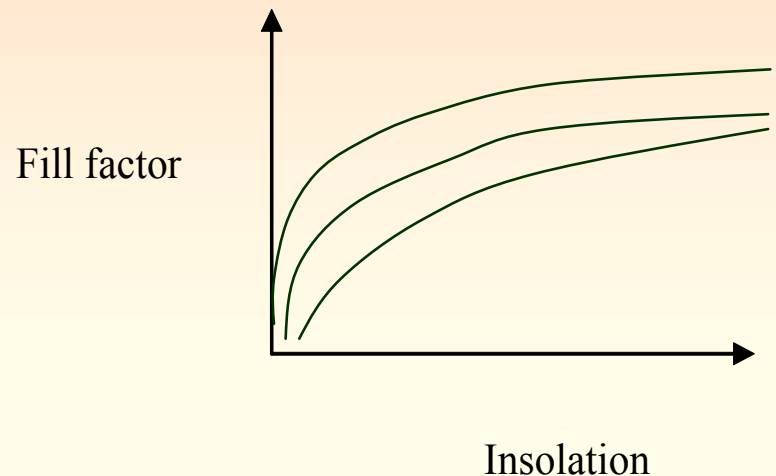
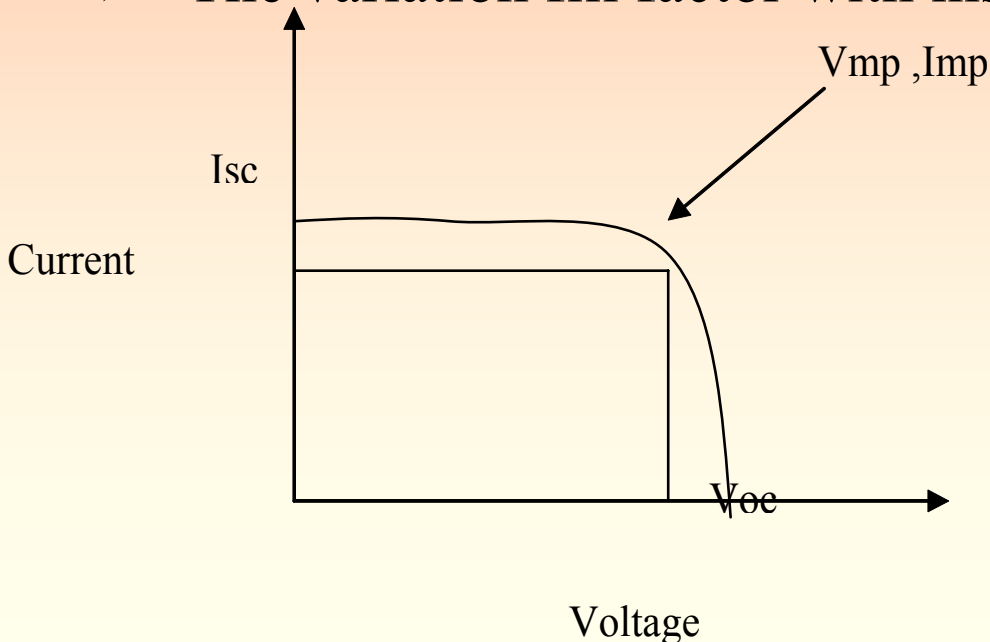

Series and Parallel combination of cells

Cells in Series

When two identical cells are connected in series, the short circuit current of the system would remain same but the open circuit voltage would be twice as much as shown in the following figure:

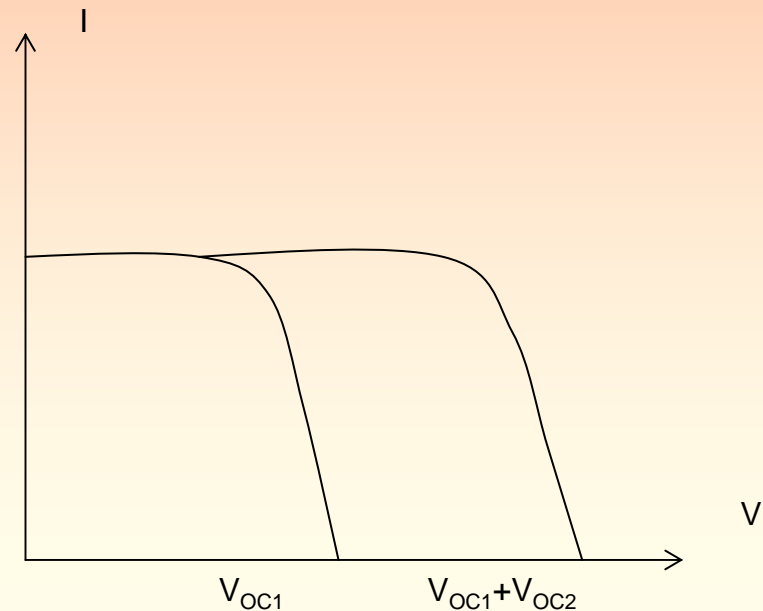
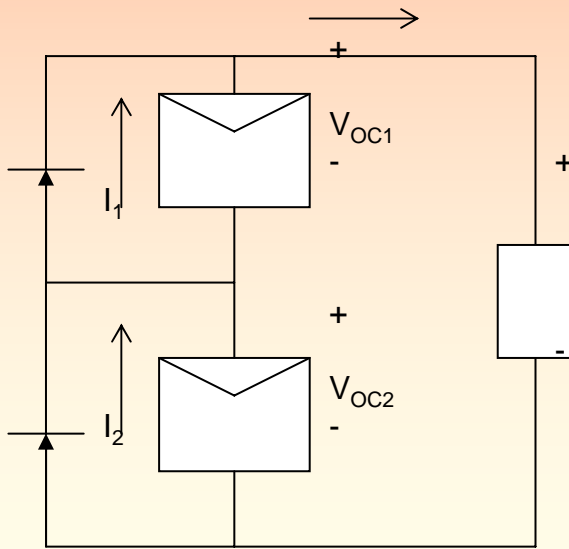

Series and Parallel combination of cells-1

- We can see from the above figures that if the cells are identical, we can write the following relationships

$$I_1 = I_2 = I$$

$$V_{OC1} + V_{OC2} = 2V_{OC}$$

- Unfortunately, it is very difficult to get two identical cells in reality.
- Hence, we need to analyze the situation little more closely.
- Let I_{SC1} be the short circuit current and V_{OC1} be the open circuit voltage of first cell and I_{SC2} and V_{OC2} be the short circuit current and open circuit voltage of the second cell.

Series and Parallel combination of cells-2

- When we connect these in series, we get the following V-I characteristics:

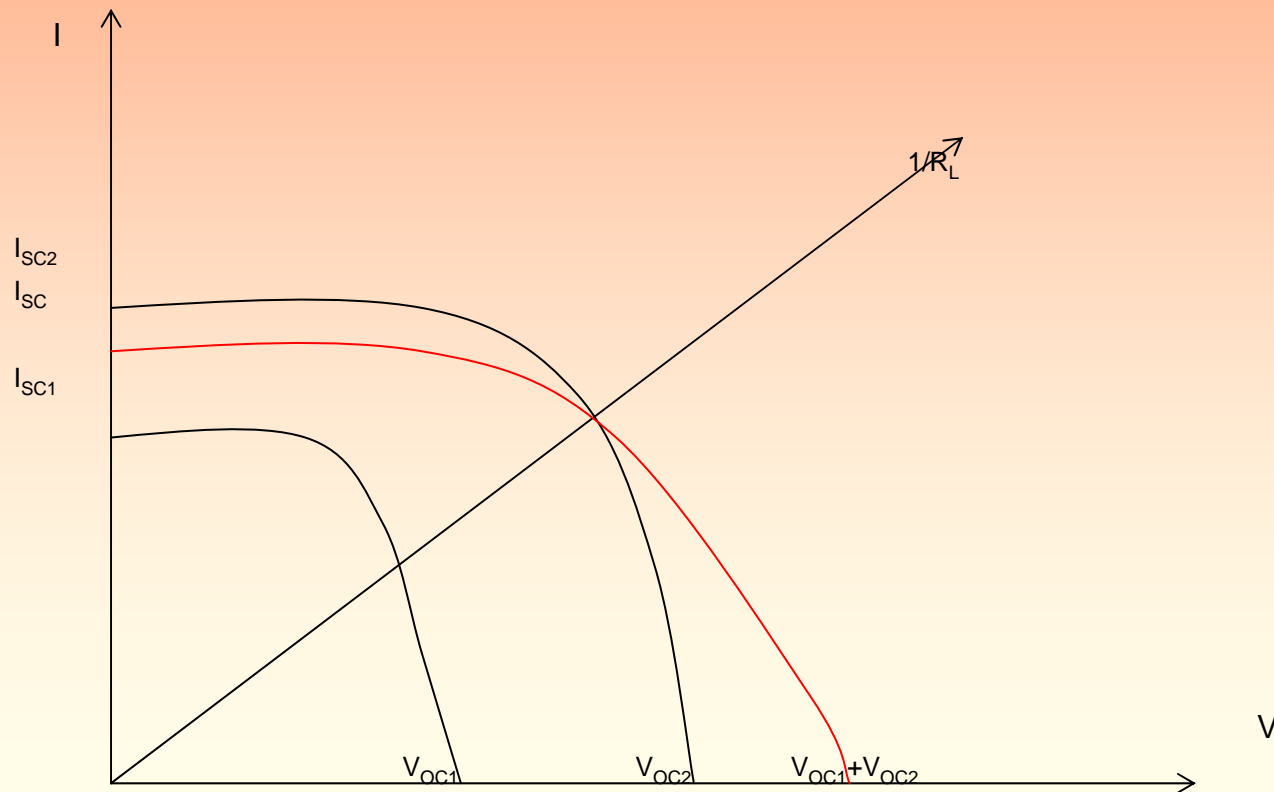

Series and Parallel combination of cells-3

- We can see from the V-I characteristics that when we connect two dissimilar cells in series, their open circuit voltages add up but the net short circuit current takes a value in between I_{SC1} and I_{SC2} shown by red color curve .
- To the left of the operating point, the weaker cell will behave like a sink.
- Hence, if a diode is connected in parallel, the weaker cell is bypassed, once the current exceeds the short circuit current of the weaker cell.
- The whole system would look as if a single cell is connected across the load.
- The diode is called a series protection diode.

Series and Parallel combination of cells-4

Cells in parallel

- When two cells are connected in parallel as shown in the following figure. The open circuit voltage of the system would remain same as a open circuit voltage of a single cell. But the short circuit current of the system would be twice as much as of a single cell.

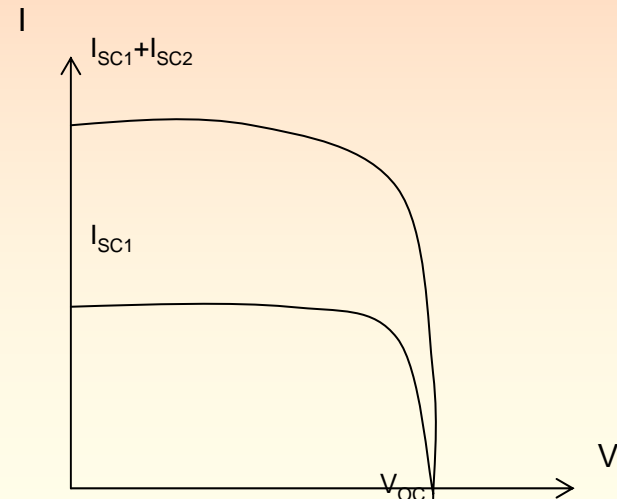
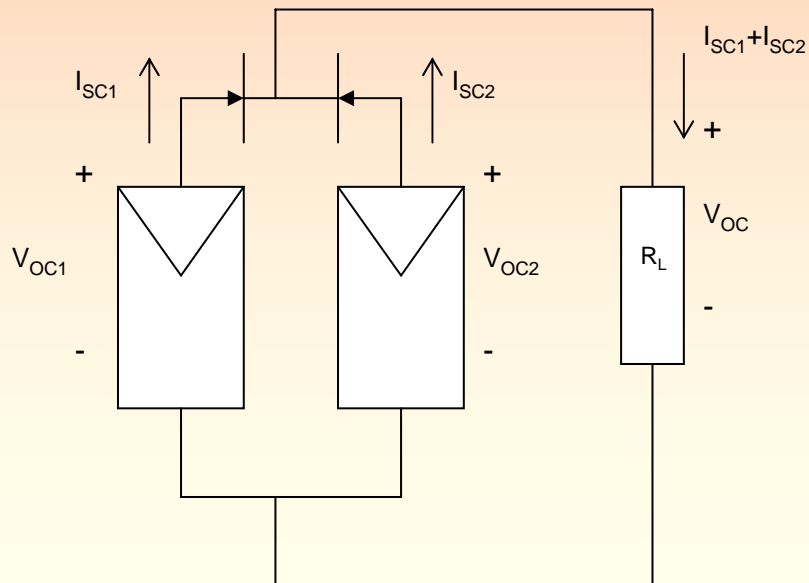

Series and Parallel combination of cells-4

- We can see from the above figures that if the cells are identical, we can write the following relationships:

$$I_{SC1} + I_{SC2} = 2I_{SC}$$

$$V_{OC1} = V_{OC2} = V_{OC}$$

- However, we rarely find two identical cells.
- Hence, let us see what happens if two dissimilar cells are connected in parallel.
- The V-I characteristics would look as shown in the following figure:

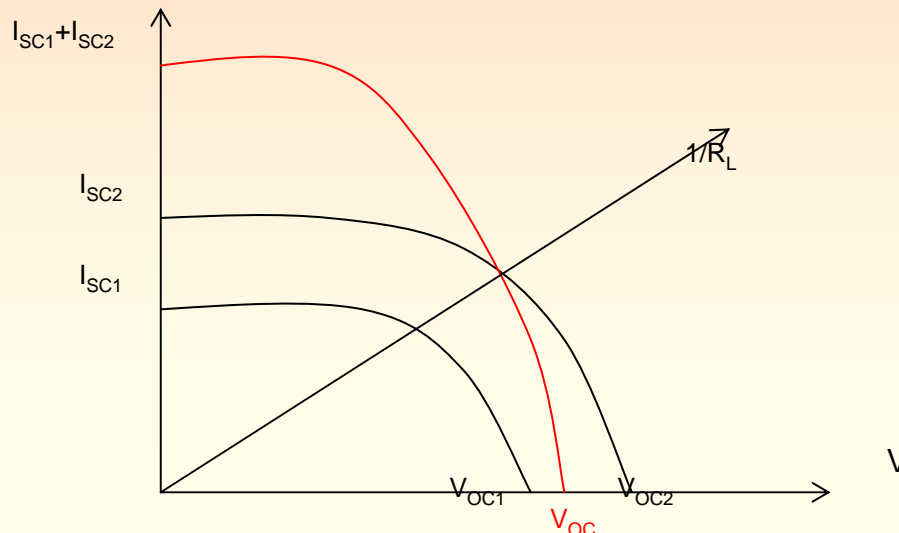

Series and Parallel combination of cells-5

- From the above figure we can infer that, when two dissimilar cells are connected in parallel, the short circuit currents add up but the open circuit voltage lies between V_{OC1} and V_{OC2} , represented by V_{OC} .
- This voltage actually refers to a negative current of the weaker cell.
- This results in the reduction of net current out of the system.
- This situation can be avoided by adding a diode in series of each cell as shown earlier.
- Once the cell is operating to the right of the operating point, the weaker cell's diode gets reverse biased, cutting it off from the system and hence follows the characteristic curve of the stronger cell.

Maximum Power Point

- We have seen in earlier section that the quality of a cell can be determined once we know ‘open circuit’ voltage.
- ‘short circuit’ current, and voltage at maximum power point and current at maximum power point.

How do we get the last two points?

- It is a two-step procedure.
- First step is to plot ‘voltage’ Vs ‘power’ graph of the cell.
- Power is calculated by multiplying voltage across the cell with corresponding current through the cell.
- From the plot, maximum power point is located and corresponding voltage is noted.

Maximum Power Point-1

- The second step is to go to the V-I characteristics of the cell and locate the current corresponding to the voltage at maximum power point. This current is called the current at maximum power point.
- These points are shown in the following figure:

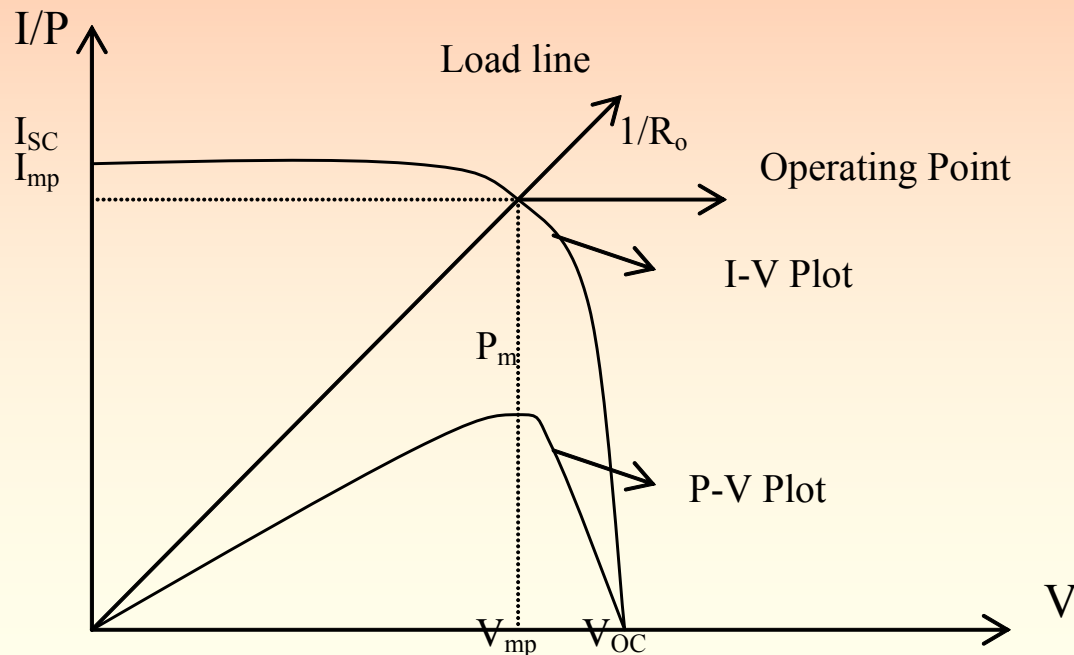

Maximum Power Point-2

- The point at which I_{mp} and V_{mp} meet is the maximum power point.
- This is the point at which maximum power is available from the PV cell.
- If the 'load line' crosses this point precisely, then the maximum power can be transferred to this load.
- The value of this load resistant would be given by:

$$R_{mp} = \frac{V_{mp}}{I_{mp}}$$

Buck Converter

- This is a converter whose output voltage is smaller than the input voltage and output current is larger than the input current.
- The circuit diagram is shown in the following figure. The conversion ratio is given by the following expression:

$$\frac{V_o}{V_{in}} = \frac{I_{in}}{I_o} = D$$

- Where D is the duty cycle. This expression gives us the following relationships:

$$V_{in} = \frac{V_o}{D}$$

Buck Converter-1

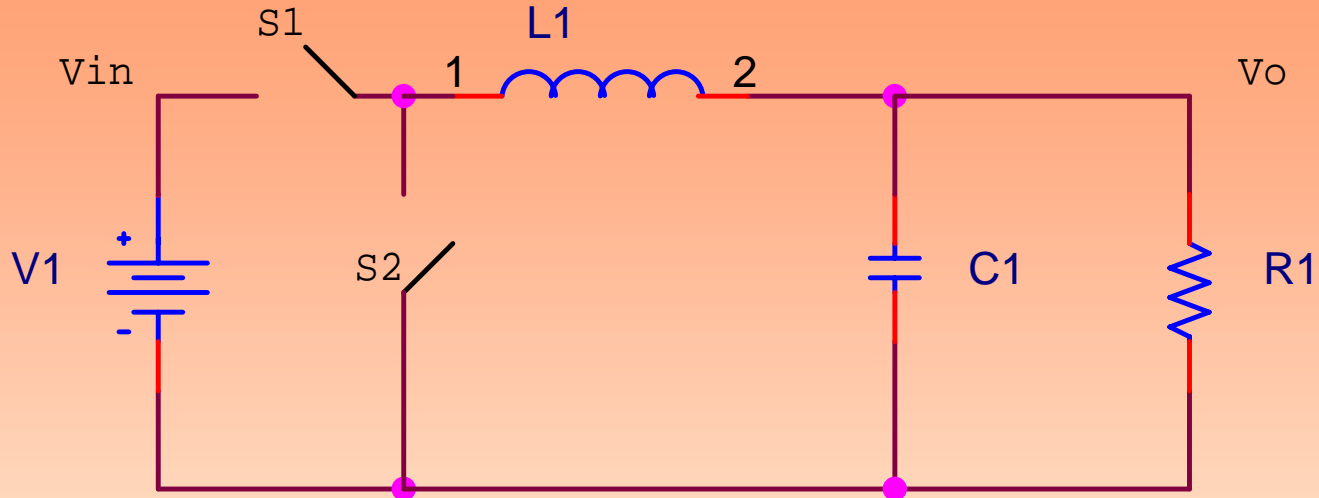

$$I_{in} = I_o D$$

Knowing V_{in} and I_{in} , we can find the input resistance of the converter. This is given by

$$R_{in} = \frac{V_{in}}{I_{in}} = \frac{(V_o / D)}{I_o D} = \frac{(V_o / I_o)}{D^2} = \frac{R_o}{D^2}$$

➤ Where R_o is the output resistance or load resistance of the converter.

Boost Converter

- This is a converter whose output voltage is larger than the input voltage and output current is smaller than the input current.
- The circuit diagram is shown in the following figure.

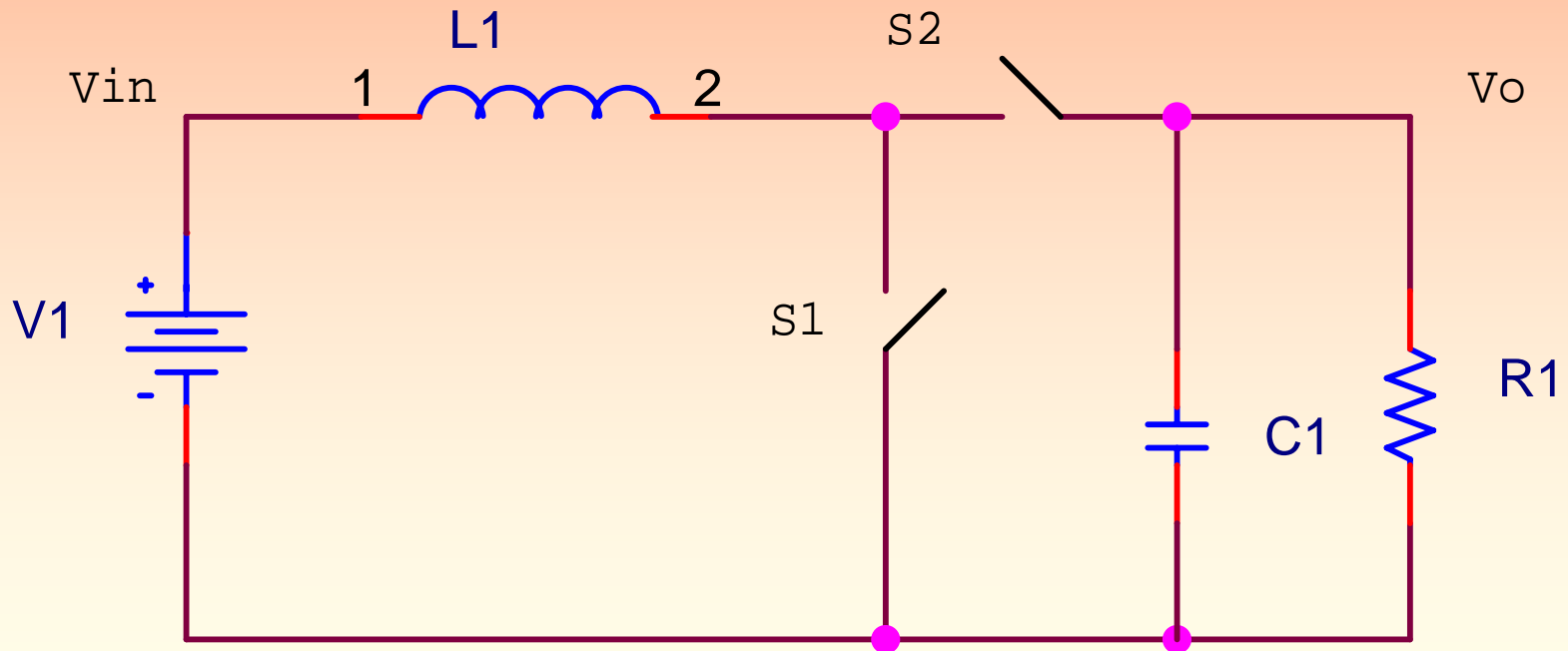

Boost Converter

- The conversion ratio is given by the following expression:

$$\frac{V_o}{V_{in}} = \frac{I_{in}}{I_o} = \frac{1}{1-D}$$

Where D is the duty cycle. This expression gives us the following relationships: $V_{in} = V_o(1-D)$

$$I_{in} = \frac{I_o}{1-D}$$

Knowing V_{in} and I_{in} , we can find the input resistance of the converter. This is given by

$$R_{in} = \frac{V_{in}}{I_{in}} = \frac{V_o(1-D)}{(I_o/(1-D))} = \left(\frac{V_o}{I_o}\right)(1-D)^2 = R_o(1-D)^2$$

Here, R_{in} varies from R_o to 0 as D varies from 0 to 1 correspondingly.

Buck-Boost Converter

- As the name indicates, this is a combination of buck converter and a boost converter.
- The circuit diagram is shown in the following figure:

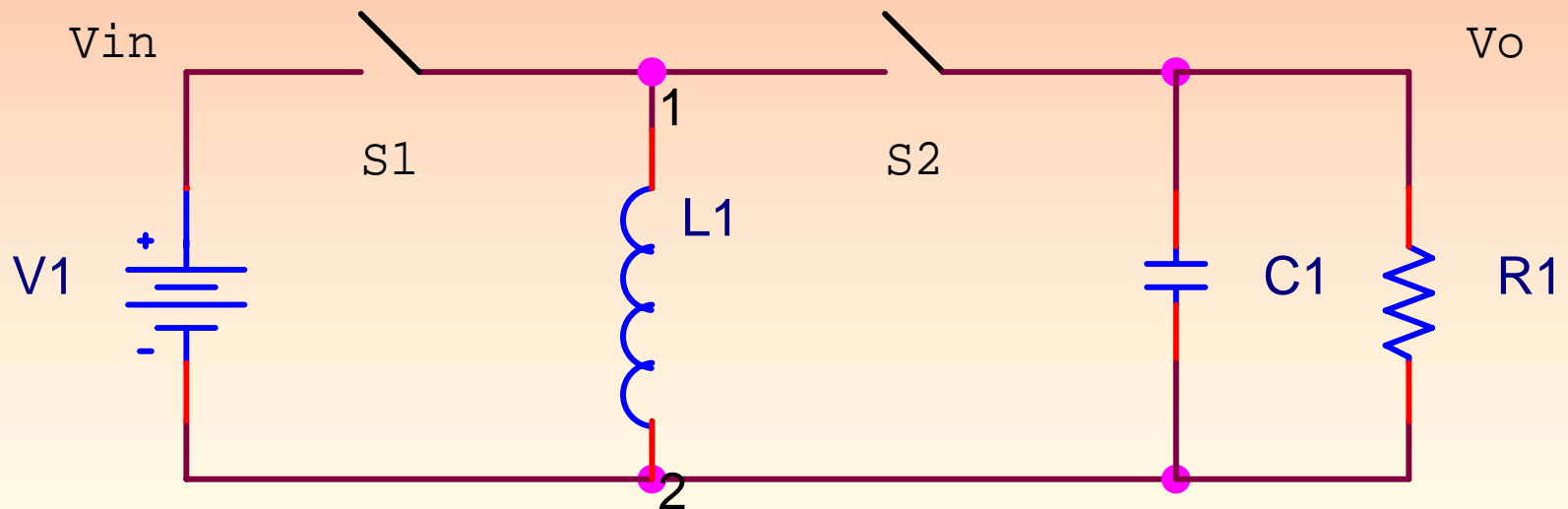

Buck-Boost Converter

➤ Here, the output voltage can be increased or decreased with respect to the input voltage by varying the duty cycle.

➤ This is clear from the conversion ratio given by the following expression:

$$\frac{V_o}{V_{in}} = \frac{I_{in}}{I_o} = \frac{D}{1-D}$$

Where D is the duty cycle. This expression gives the following relationships:

$$V_{in} = V_o \left(\frac{1-D}{D} \right)$$

$$I_{in} = I_o \left(\frac{D}{1-D} \right)$$

Knowing V_{in} and I_{in} , we can find the input resistance of the converter. This is given by

Buck-Boost Converter-1

$$R_{in} = \frac{V_{in}}{I_{in}} = \left(\frac{V_o}{I_o} \right) \left(\frac{(1-D)^2}{D^2} \right) = R_o \left(\frac{(1-D)^2}{D^2} \right)$$

Here, R_{in} varies from ∞ to 0 as D varies from 0 to 1 correspondingly.

- Now let us see how these converters come into picture of PV.
- We had seen earlier that maximum power could be transferred to a load if the load line lies on the point corresponding to V_m and I_m on the V-I characteristics of the PV cell/module/panel.
- We need to know at this point that there is always an intermediate subsystem that interfaces PV cell/module and the load as shown in the following figure:

Buck-Boost Converter-2

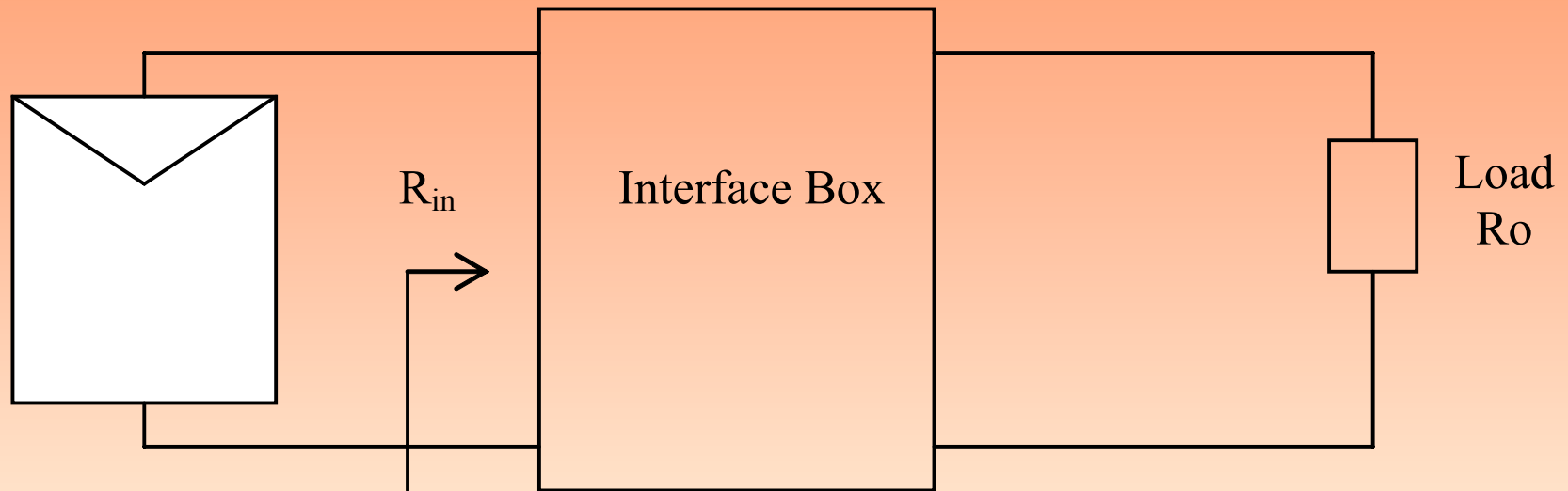

- This subsystem serves as a balance of system that controls the whole PV system.
- DC-to-DC converter could be one such subsystem.
- So far we have seen three different types of converters and its input resistance R_{in} 's dependency on the load resistance and the duty cycle.

Buck-Boost Converter-3

- To the PV cell/module, the converter acts as a load and hence we are interested in the input resistance of the converter .
- If we see that R_{in} of the converter lies on the V_{mp} - I_{mp} point, maximum power can be transferred to the converter and in turn to the load.
- Let us see the range of R_{in} values for different converters as shown in the following figures:

Buck Converter:

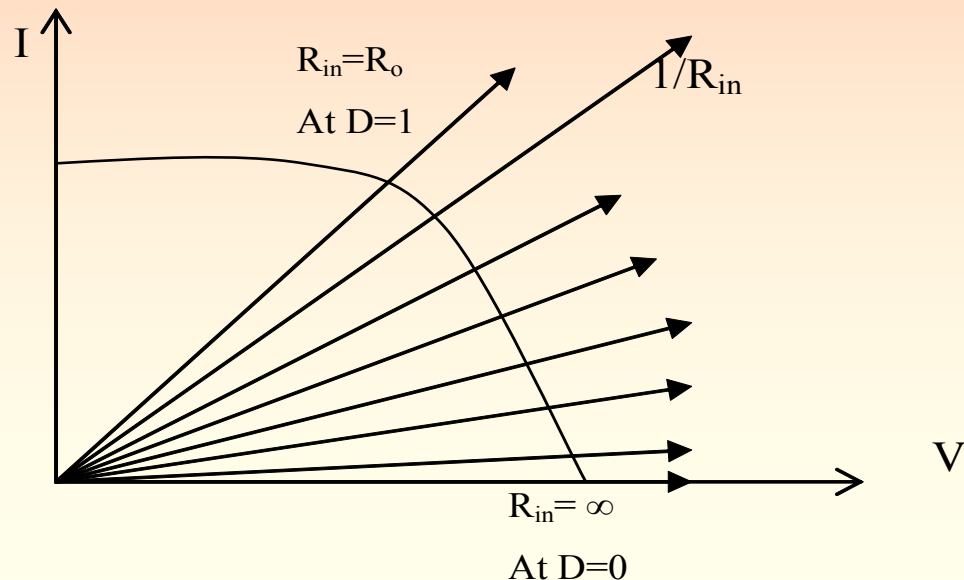

Buck-Boost Converter-4

Boost Converter:

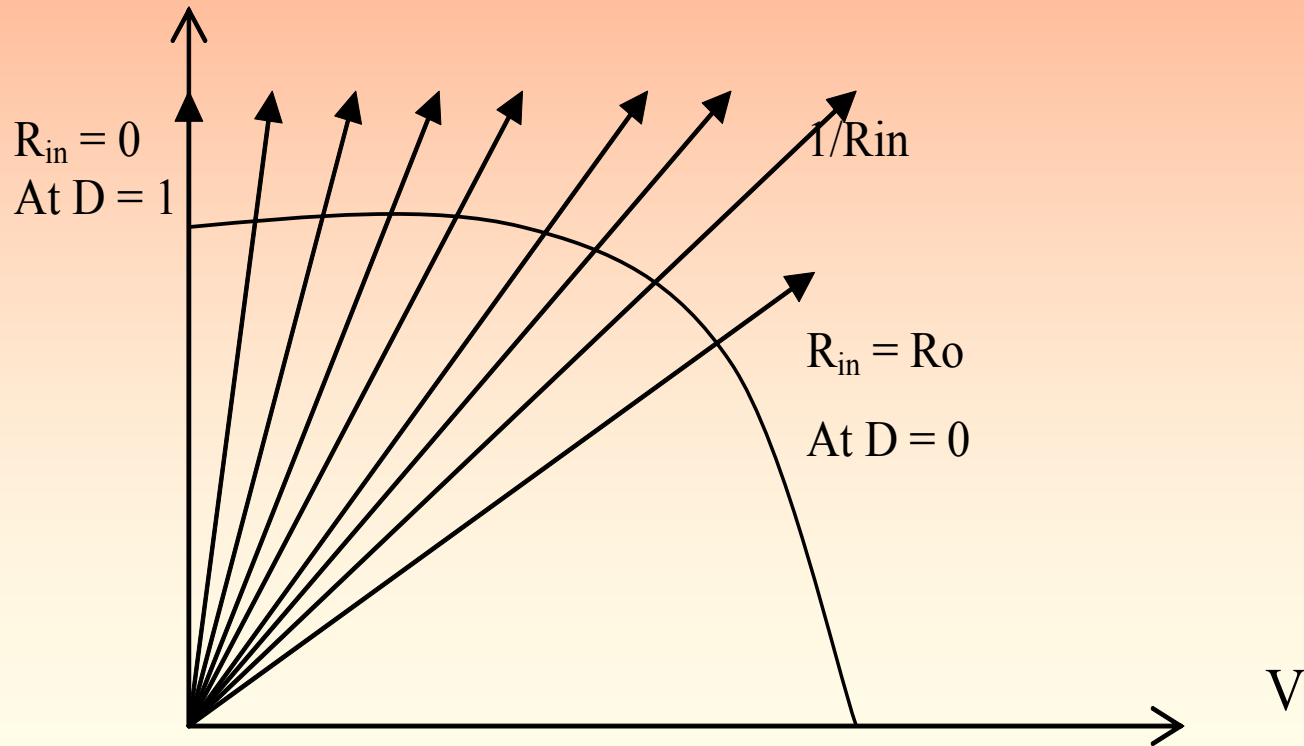

Buck-Boost Converter-5

Buck-Boost Converter:

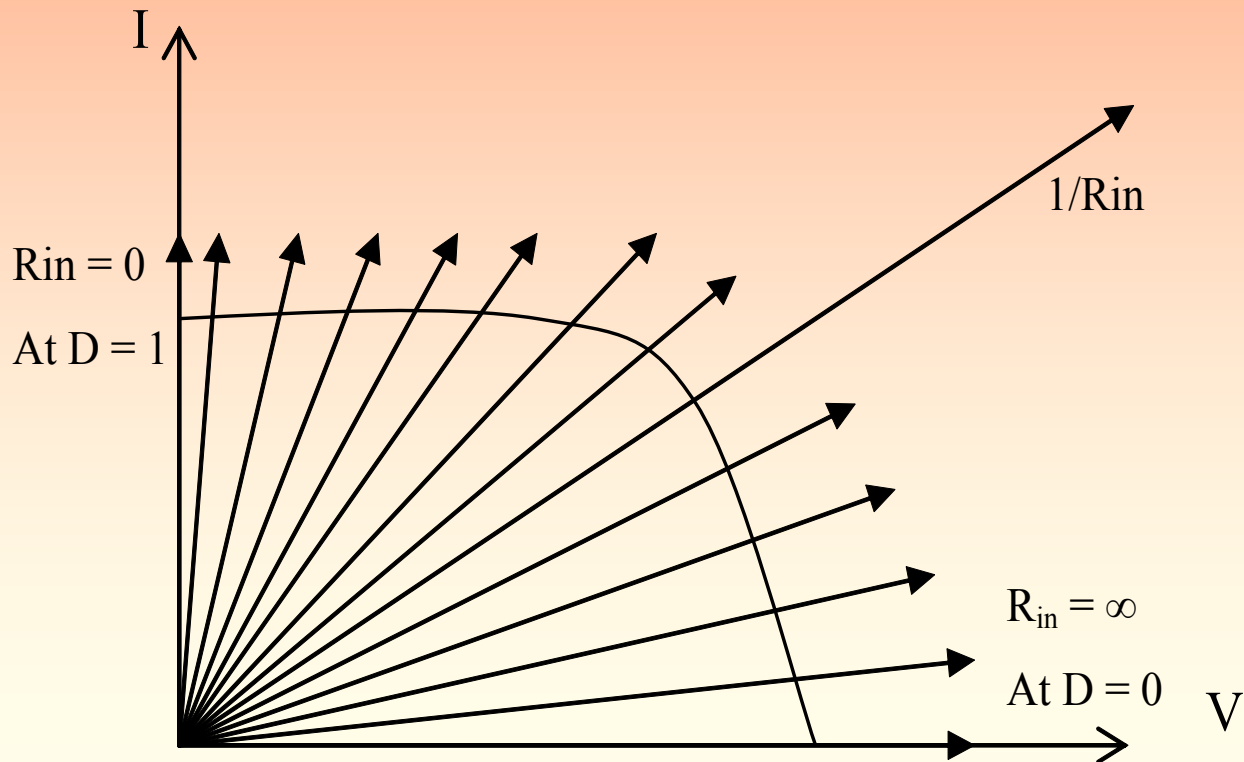

An Example of DC – DC Converter:

- In our earlier discussion we have seen different types of DC – DC converters such as Buck, Boost and Buck – Boost converters
- We had also seen the range of operation in conjunction with the PV cell/module characteristics.
- The selection of type of converter to be used for an application would depend on the operating point of the load.
- However, we have seen that the range of operation of Buck – Boost converter covers the entire V-I characteristics of the PV cell/module and hence it is a safe converter to be picked for any application.

An Example of DC – DC Converter:-1

- Following figure gives a general block diagram of the whole system incorporating DC – DC converter:

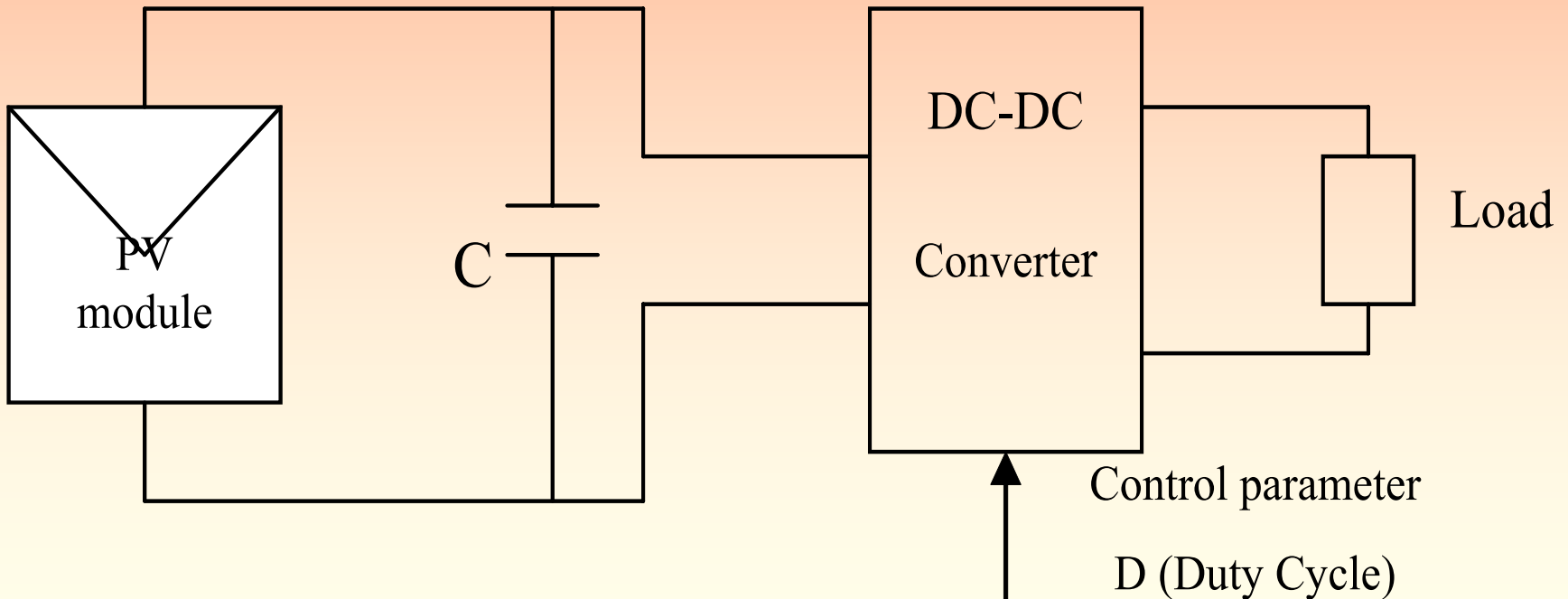

An Example of DC – DC Converter:-2

- A capacitor is connected at the output of the PV module to eliminate any ripple or noise present.
- Normally a high value of capacitor is chosen to do the job.
- The capacitor also provides a constant voltage to the input of the DC – DC converter.
- We had seen earlier that the conversion ratio of any converter is a function of duty cycle and hence it becomes the control parameter to the converter.
- Let us take a Buck – Boost converter in detail, as it is the most versatile converter that can be used in any application and for any operating point.

An Example of DC – DC Converter:-3

- The circuit diagram of a Buck - Boost converter is shown in the following figure:

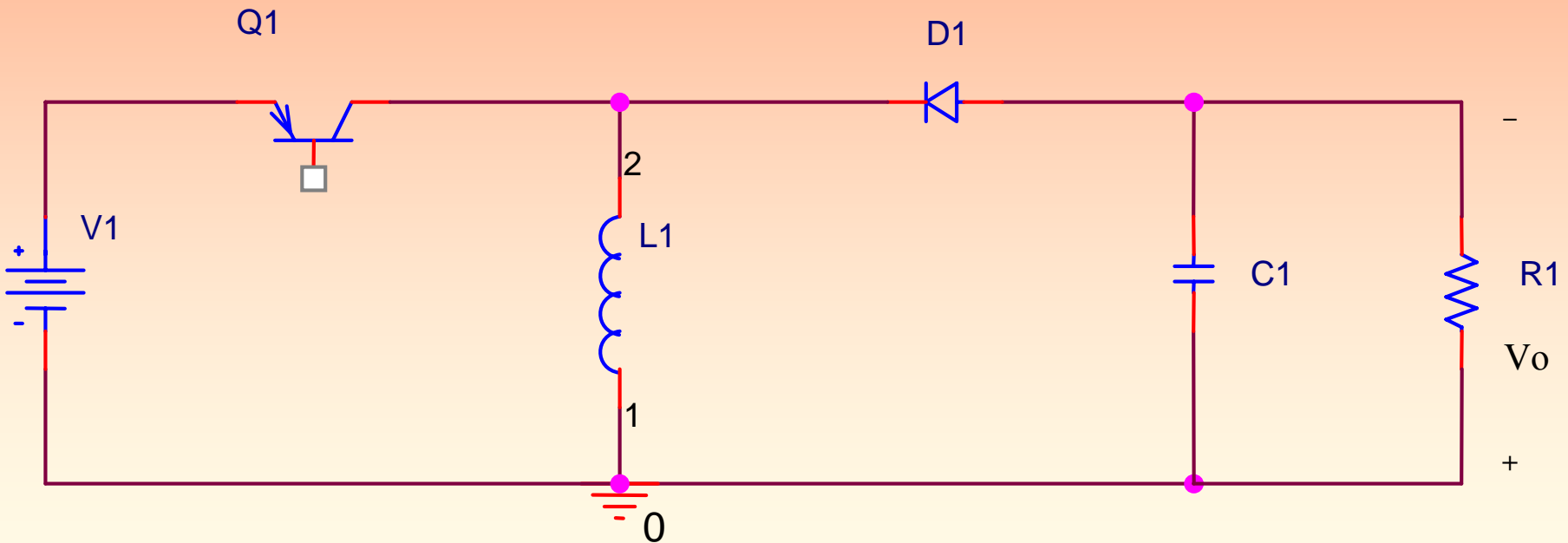

Q_1 and D_1 are the two switches, which are open one at a time.

An Example of DC – DC Converter:-4

- To derive an expression for the conversion ratio, we can apply any of the following principles under steady state conditions:
- Volt-Second balance across inductor L1.
- Amp-Second balance across capacitor C1.
- If one of the above two are obtained, power balance across the entire circuit.
- That is, assuming zero losses in the circuit,
$$\text{input power} = \text{output power}.$$

Let us apply volt-second balance to the inductor. The voltage across inductor for Q1-ON, D1-OFF and for Q1-OFF, D1-ON, assuming negligible ripple is as shown in the following figure:

An Example of DC – DC Converter:-5

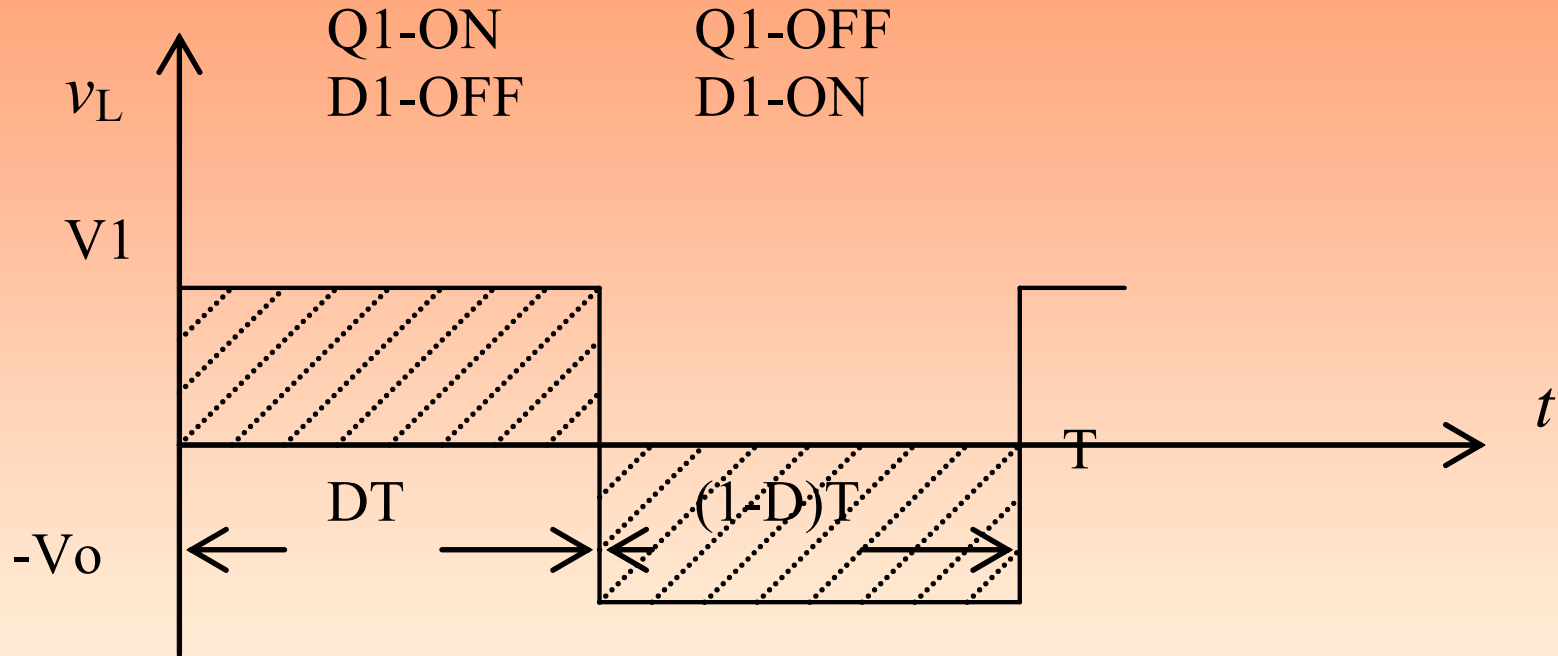

Applying volt-second balance we get:

$$V_1 \cdot DT + [-V_o \cdot (1-D)T] = 0$$

$$V_1 \cdot D = V_o \cdot (1-D)$$

$$\frac{V_o}{V_1} = \frac{D}{1-D} = M(D) = \text{Conversion Ratio}$$

An Example of DC – DC Converter-6

- Conversion ratio can also be derived by using Amp-second balance.
- We can see that the conversion ratio is a function of the duty cycle D .
- Let us set up an experiment to see the relationship between the duty cycle and the panel characteristics.
- Let us use the Buck - Boost converter to transfer DC voltage of the panel to the load.

Let us use TL494 – SMPS for controlling the duty cycle. To construct Buck-Boost converter, we need the following parts:

An Example of DC – DC Converter:-7

- A pnp transistor for active switching – TIP127.
- A diode for passive switching – IN4007.
- Two resistors for biasing the transistor.
- A load resistor of 10 Ω and 100 Ω .
- Two capacitors, one at the output of the PV module and one as a part of the converter – 1000 μF .
- A resistor and a capacitor for changing the duty cycle, to be connected externally to TL494.
- A one k Ω resistor connected to Dead Time Control pin (DT) of TL494.
- A 5V supply connected to VCC terminal of TL494.

An Example of DC – DC Converter-8

- The biasing and duty cycle components are to be designed. Once all the components value are known and procured, they can be rigged up as shown in the following figure:

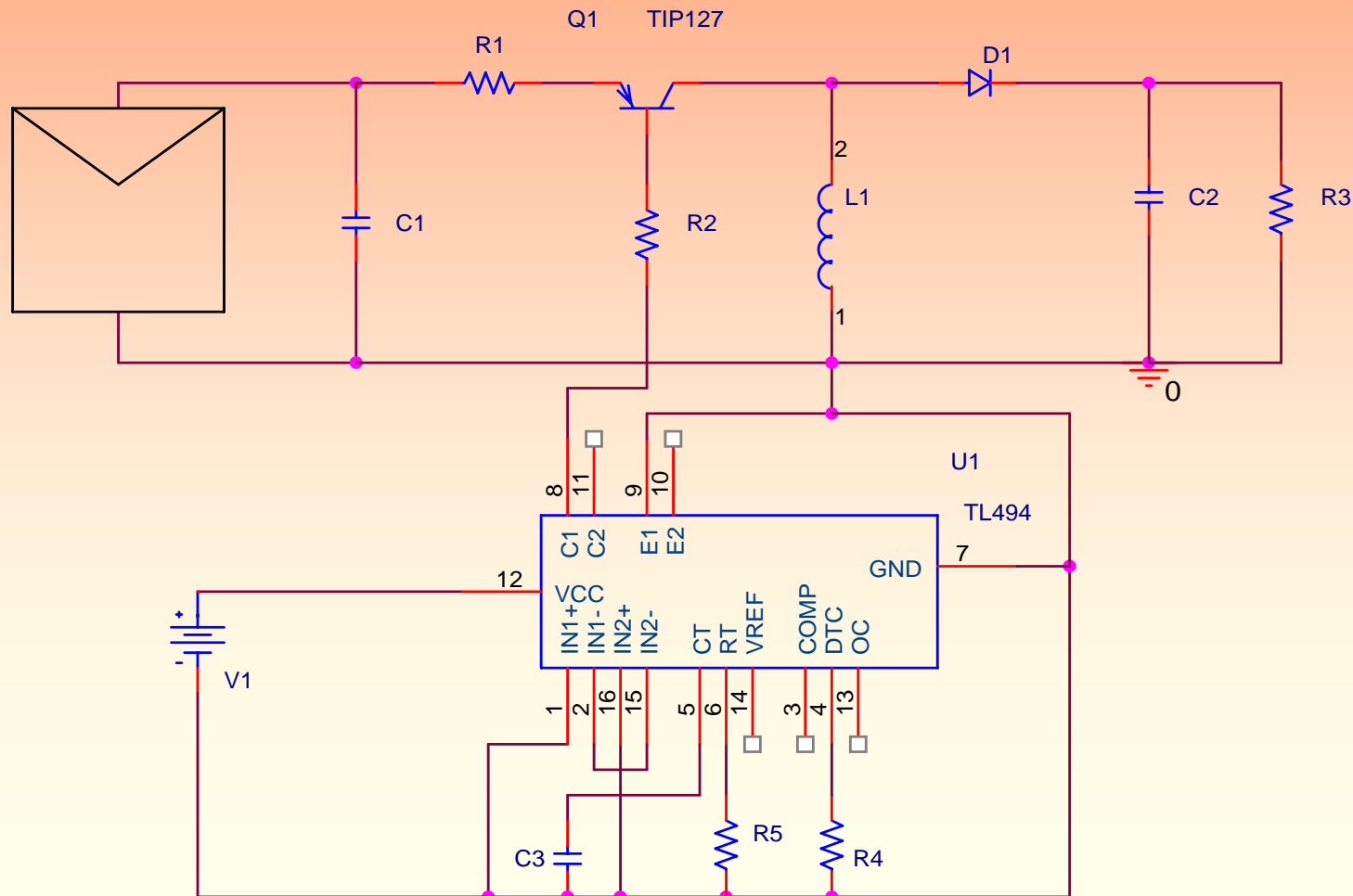

An Example of DC – DC Converter:-9

- The procedure for doing the experiment is as follows. After rigging up the circuit setting $R_3 = 10 \Omega$, the module currents and module voltages are measured for different duty cycle.
- The duty cycle can be set by varying the values of C_T and R_T connected to P_{in} numbers 5 and 6 of TL494.
- From the readings of V_{module} and I_{module} , power of the module and R_{in} for the converter can be calculated for each duty cycle.
- From the P-V plot and I-V plot of the module, several parameters can be found such as P_{mp} , I_{mp} , V_{mp} and D_{mp} .
- We can also verify that the R_{in} calculated is equal to the R_{in} expression we had derived earlier for a buck-boost converter given by:

$$R_{in} = R_o \left(\frac{(1-D)^2}{D^2} \right)$$

An Example of DC – DC Converter:-10

The values can be tabulated as shown in the following table:

$R3$	D	I_{mod}	V_{mod}	$P_{\text{mod}} = I_{\text{mod}} \cdot V_{\text{mod}}$	$R_{\text{in}} = \frac{V_{\text{mod}}}{I_{\text{mod}}}$	$R_{\text{in}} = R_o \left(\frac{(1-D)^2}{D^2} \right)$
10 Ω	0.1					
	0.3					
	0.5					
	0.7					
	0.9					

The experiment is repeated by replacing R3 value by 100 Ω .

Maximum power point tracking

- We had seen in the experimental set-up how to locate the maximum power point for a given load by physically varying the duty cycle that controlled the DC-DC converter.
- From the maximum power point, we could find the values of I_{mp} , V_{mp} and D_{mp} .
- In real life situations, one needs to have a system that automatically sets the D value to D_{mp} such that maximum power can be transferred to the load.
- This is called Maximum Power Point Tracking or MPPT.
- The current from the panel depends directly on insolation. This means that the V-I characteristics of a panel would change whenever there is a change in the insolation.

Maximum power point tracking-1

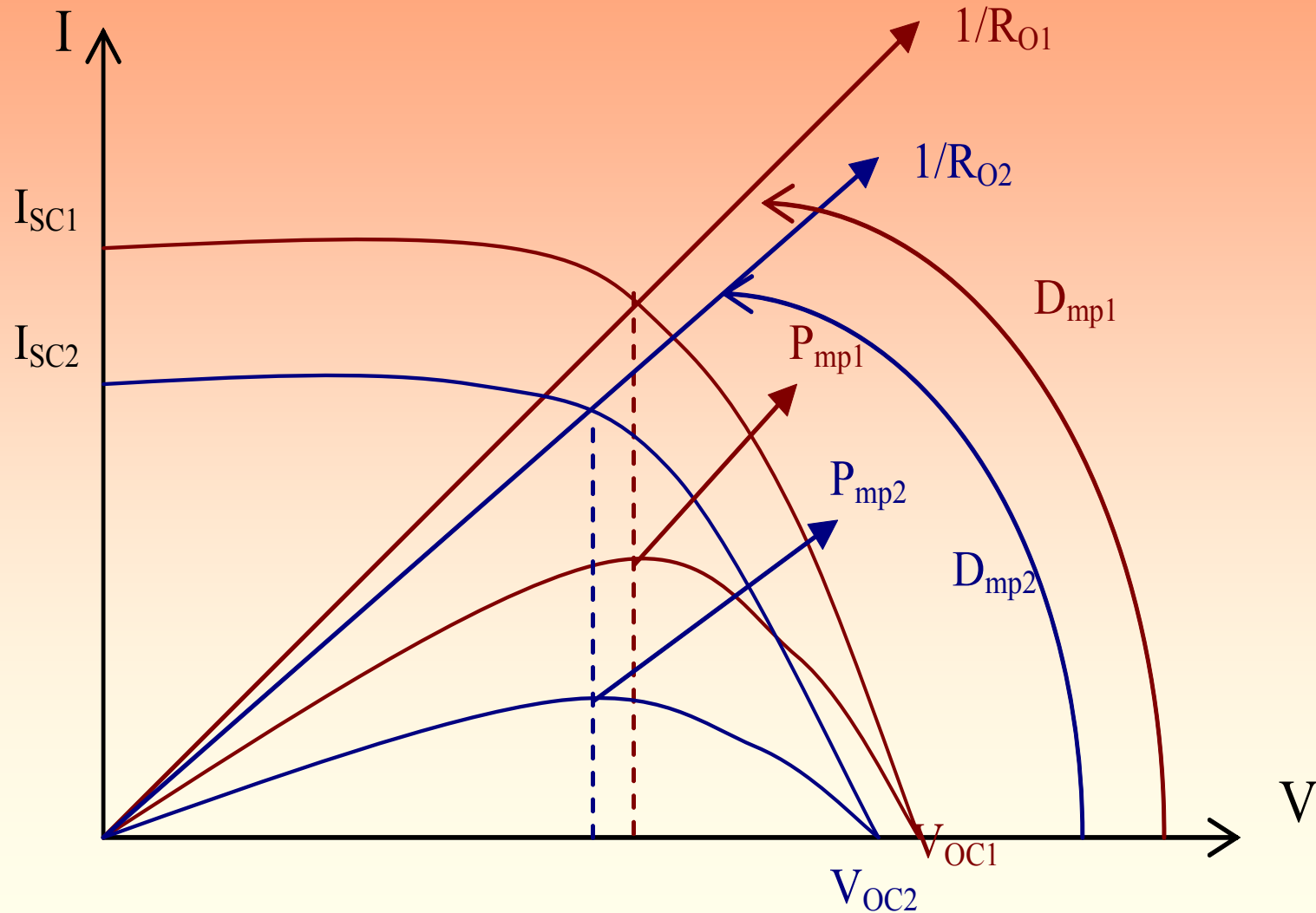

Maximum power point tracking-2

- In the figure, I_{SC1} , V_{OC1} and P_{mp1} are the short circuit current, open circuit voltage and maximum power point of the module at instant 1.
- $1/R_{o1}$ is the slope of the load line that cuts the V-I characteristics of the module corresponding to P_{mp1} .
- maximum power is transferred to the load.
- I_{SC2} , V_{OC2} and P_{mp2} are the short circuit current, open circuit voltage and maximum power point of the same panel at reduced insolation that we call as instant 2.
- Now $1/R_{o2}$ is the slope of the load line that would cross the characteristic curve corresponding to P_{mp2} .

Maximum power point tracking-3

- we know that R_{o1} is the actual load and that cannot be changed.
- we need to translate the load R_{o1} to R_{o2} such that maximum power can be transferred to it.
- This is achieved by changing the value of D_{mp} which controls the power conditioner circuit.
- The power conditioner circuit could be any of the types of dc-dc converters.
- We had seen earlier that actual load is connected to the output of a converter and there is a relationship between input resistance and output resistance of the converter.

Maximum power point tracking-4

- We also know that the input resistance of the converter is same as the output resistance of the PV cell/module.
- we can have a relationship between the output resistance of the PV cell/module and the actual load. For maximum power transfer using buck-boost converter, we may have the following relationship:

$$R_{out(module)} = R_{o(Load)} \cdot \frac{(1 - D_{mp})^2}{D_{mp}^2}$$

Maximum power point tracking-5

- Since $R_{o(\text{Load})}$ cannot be changed, the right hand side quantity can be matched to $R_{\text{out}(\text{module})}$ by changing the value of D_{mp} through a feedback network as shown in the following block diagram:

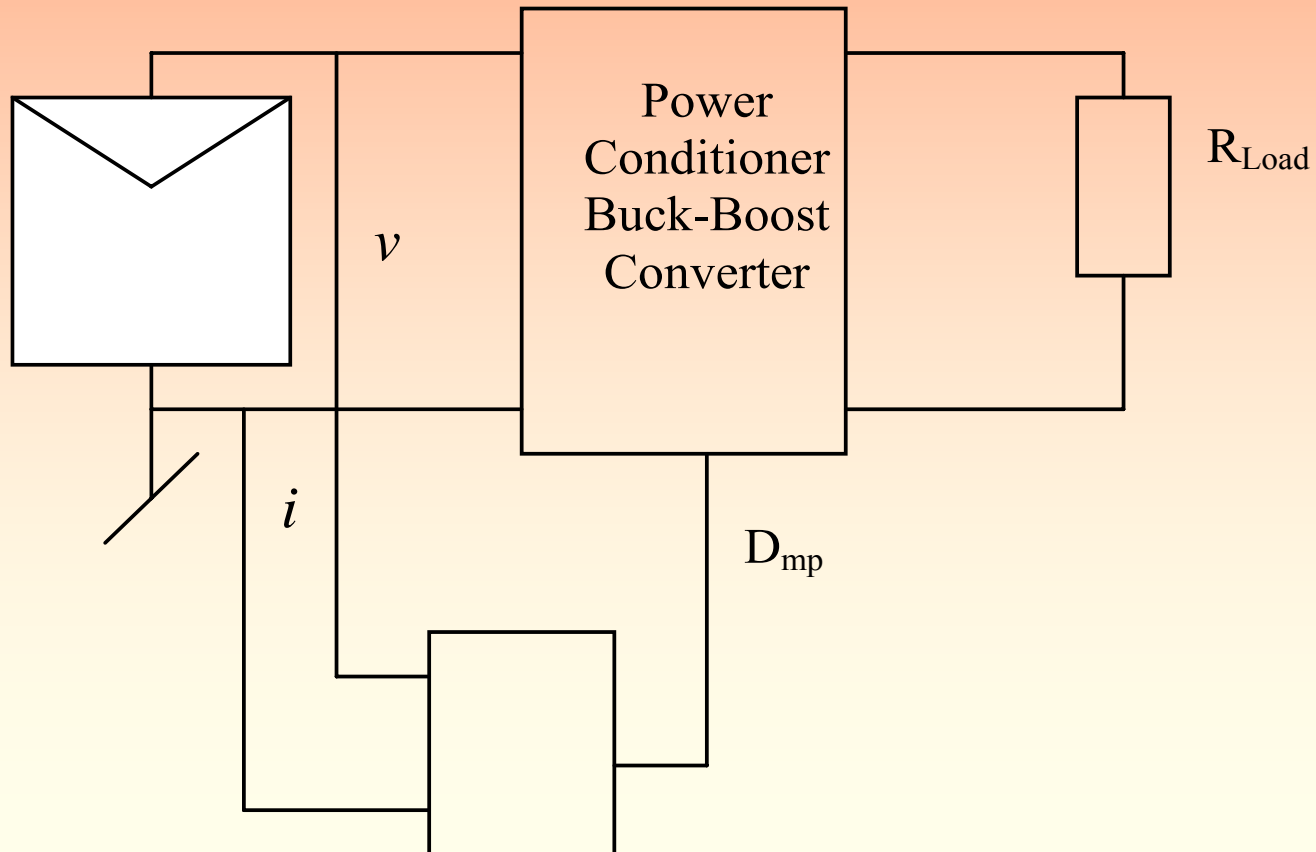

Maximum power point tracking-6

- Therefore, maximum power point tracking system tracks the maximum power point of the PV cell/module and adjusts D_{mp} from the feedback network based on the voltage and current of the PV module to match the load.
- Let us take an example of charging a battery (load) using a PV module.
- Following are the steps that we need to follow before we connect the load to the module.
- Obtain source (PV module) V-I characteristics .
- Obtain load (battery) V-I characteristics.
- Check for intersection of the characteristics and stability. This would be the operating point.

Maximum power point tracking-7

- In the example, let us try to charge a 24 V battery with a PV module having V_{OC} 20 V as shown in the following block diagram:

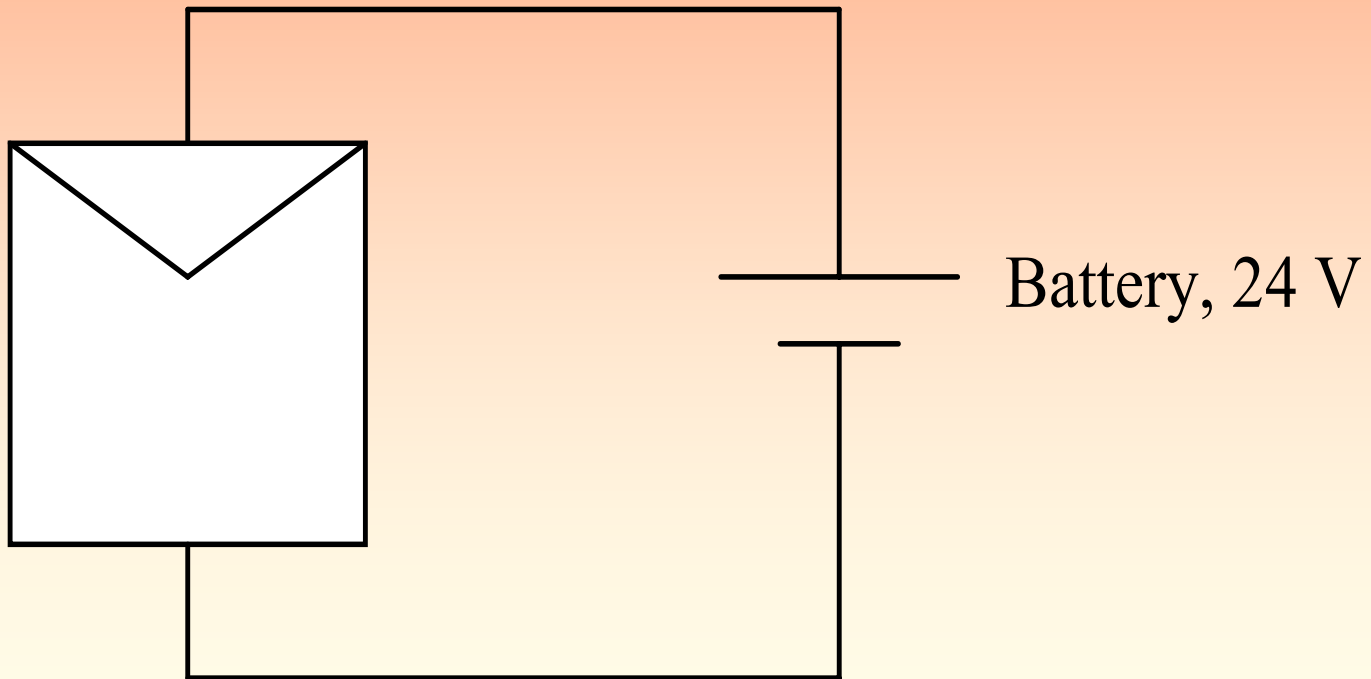

Maximum power point tracking-8

- Following the above-mentioned steps, let us obtain the V-I characteristics of load and source and superpose one over the other. Following are the characteristics:

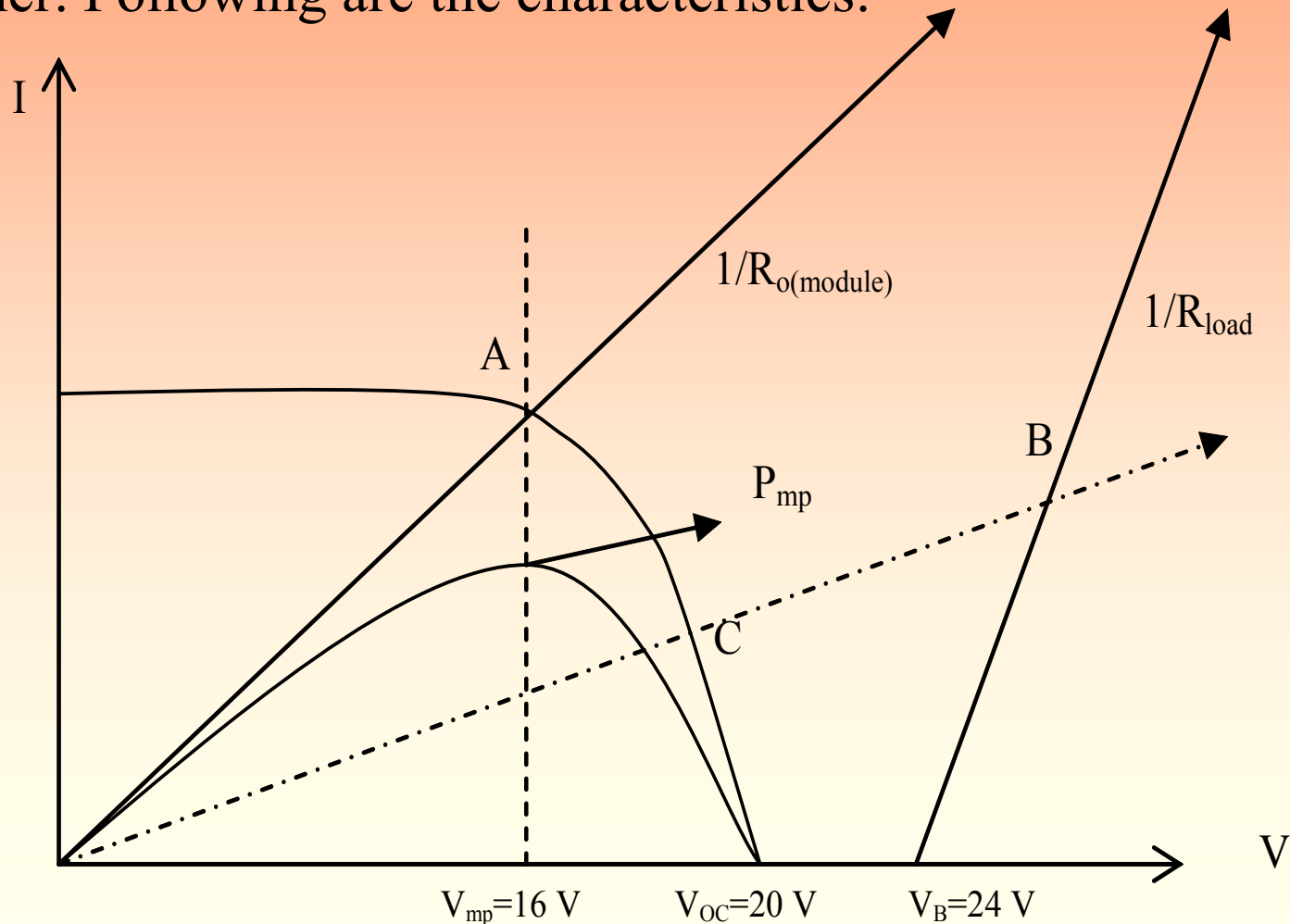

Maximum power point tracking-9

- We can see in the figure that the V-I characteristics of the PV module and the load (battery) do not intersect at any point.
- Hence, we need to have a power conditioner circuit to match the loads.
- Since we need to charge a 24-volt battery and we have only V_{mp} of 16 V from the PV module, we can use either a boost converter or a buck-boost converter.
- Ideally, the V-I characteristics of the battery should be a vertical line indicating a constant voltage source.
- However, we see a slope. This is due to the internal resistance of the battery.

Maximum power point tracking-10

- Hence, the battery can be modeled as a voltage source in series with a resistance as shown in the following figure:

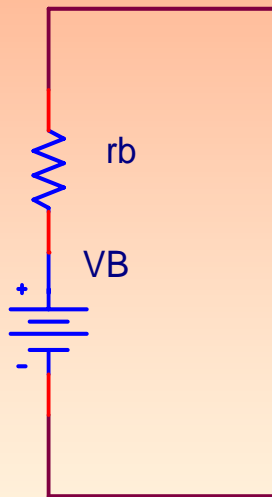

- In the V-I characteristics, we also notice three important points marked as A, B and C.

Maximum power point tracking-11

- 'A' represents the peak power point (V_{mp} , I_{mp}), 'B' represents the operating point of the battery and 'C' represents the intersection point of load line with the V-I characteristics of the PV module.
- We know that as such maximum power cannot be transferred to the load since the load line does not pass through the peak power point (A).
- However, this load line can be translated by varying the duty cycle D to the converter such that it matches with the output resistance of the PV module governed by the relationship given earlier.

Algorithms for MPPT

- We have seen that any PV module would have a maximum power point for given insolation.
- If a load line crosses at this point, maximum power would be transferred to the load.
- When insolation changes, maximum power point also changes.
- Since the load line does not change, it does not pass through the maximum power point and hence maximum power cannot be transferred to the load.
- To achieve the transfer of maximum power, it requires that the load follows the maximum power point .

Algorithms for MPPT-1

- This is achieved by translating the actual load line point to maximum power point by varying the duty cycle governed by the following relationship in the case of buck-boost converter:

$$R_{out(module)} = R_{o(Load)} \cdot \frac{(1 - D_{mp})^2}{D_{mp}^2}$$

- Maximum power point tracking can be achieved in a number of ways .

Algorithms for MPPT-2

- One of the simpler ways based on Reference Cell is shown in the following block diagram:

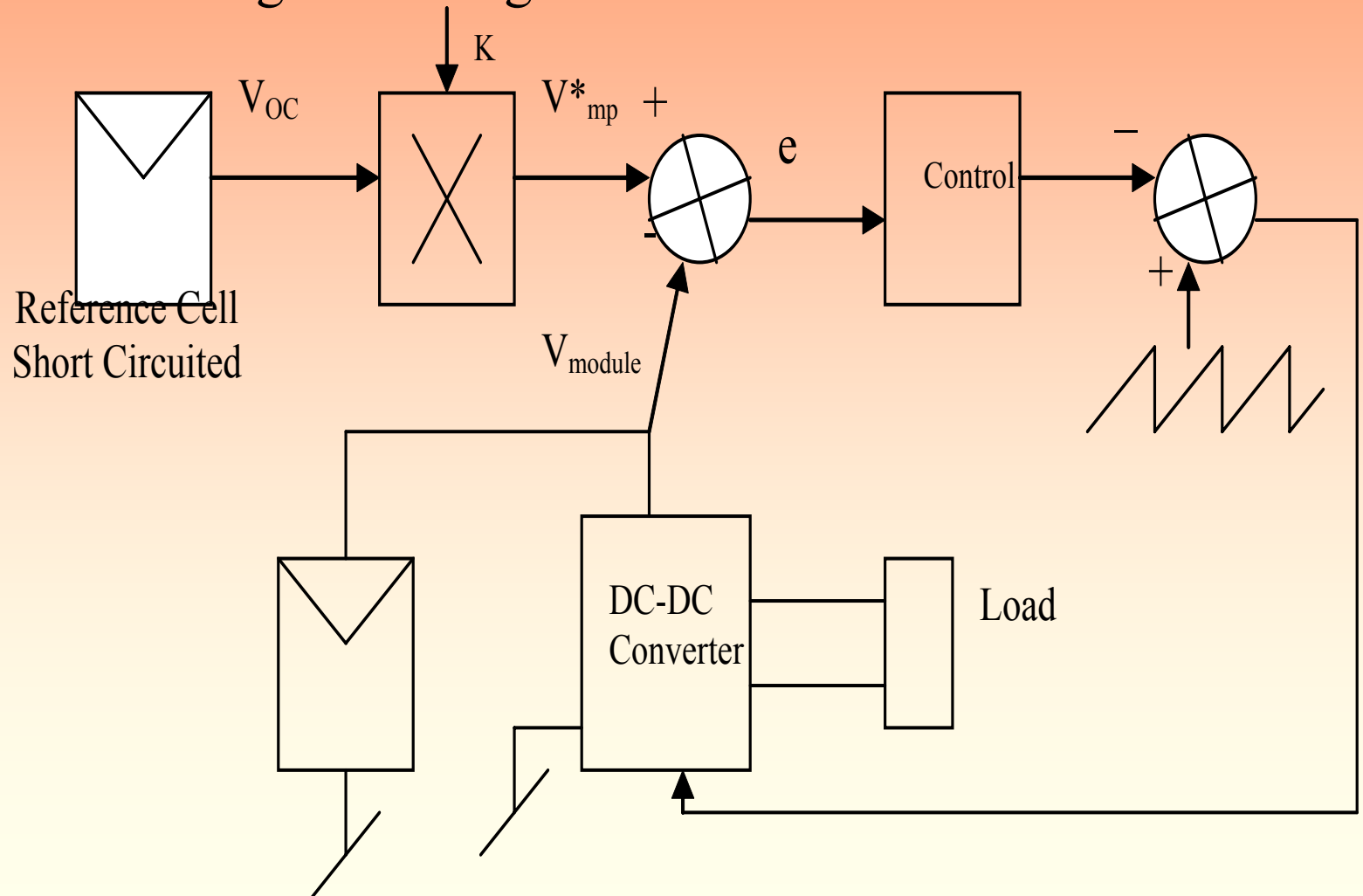

Algorithms for MPPT-3

- The first step is to define $K = (V_{mp}/V_{OC})$ where $0 < K < 1$. In the block diagram, reference cell is supposed to be an identical cell that is being used in an application.
- The V_{mp} of this cell is used to compare the voltage of the actual cell.
- V_{mp} of the reference cell is obtained by multiplying V_{OC} with K .
- When V_{module} matches with V_{mp} , there will be zero error and the module is delivering maximum power.
- If error is not zero, then the error signal is fed into a controller that would create a rectangular pulse of appropriate duty cycle which is fed to the power conditioner circuit (here it is a DC-DC converter).

Algorithms for MPPT-4

- Depending on the D value, V_{module} would change.
- Once V_{module} matches with V_{mp} of the reference cell, then we know that maximum power is transferred to the load.
- At this point the error signal is zero and the D value remains same as long as the error signal remains zero.

The control works as follows:

- If V_{module} increases beyond V_{mp} , the error becomes negative.
- This would make the control unit to generate pulses with larger D value.
- This decrease V_{module} automatically such that it matches with V_{mp} .
- if V_{module} decreases below V_{mp} , we get a positive error.

Reference Cell Based algorithm-Method 2

- A second method based on Reference cell based algorithm is to define K as a ratio of Current at maximum power point to the Short circuit current of the module given by:

$$K = \frac{I_{mp}}{I_{SC}}$$

- This is more constant than the ratio of Voltage at maximum power point to open circuit voltage of the module since the module current is linearly related to the insolation .

Reference Cell Based algorithm-Method 2

➤ The following block diagram describes the algorithm:

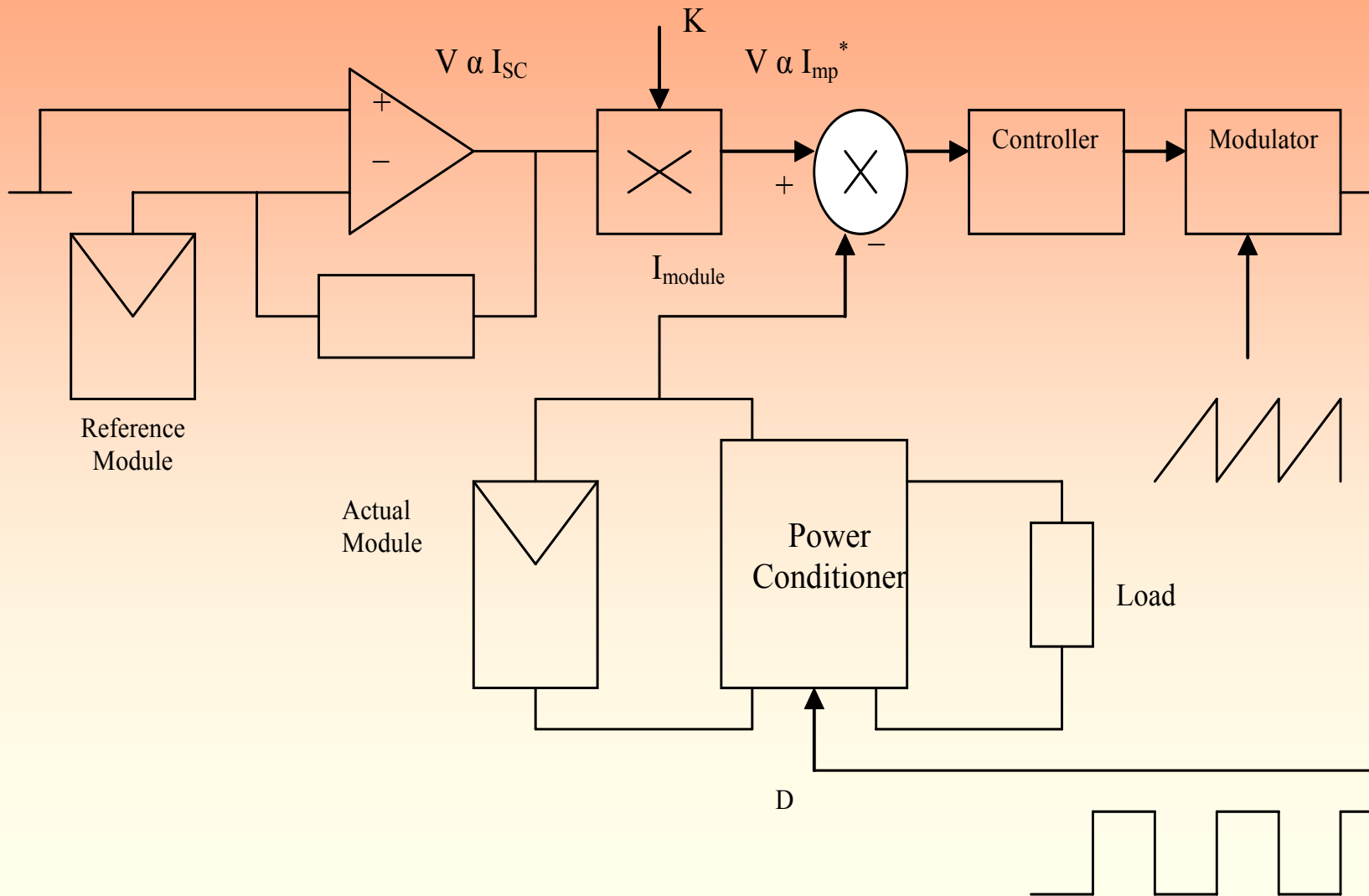

Reference Cell Based algorithm-Method 2

- Current from the reference cell is converted to proportional voltage through an op-amp and fed to a multiplier.
- This quantity is multiplied with K resulting in I_{mp} .
- This is compared to the current from the actual module.
- If the currents match, then the module is delivering maximum power to the load.
- If the currents do not match, an error signal is generated.
- The polarity of the signal would depend on if the module current were greater than the I_{mp} or smaller than I_{mp} .
- Let us say that the module current is smaller than I_{mp}^* , then the error produced is positive.

Reference Cell Based algorithm-Method 2

- The controller would then increase the duty cycle of the rectangular pulses coming out of the modulator and into the power conditioner circuit.
- This would result in increase of module current till it matches the I_{mp}^* and the error is zero.
- Exactly opposite happens if the module current was found to be more than I_{mp}^* initially resulting in negative error signal.
- The controller then would reduce the duty cycle that is being used as a control unit for the power conditioner circuit.
- The module current decreases till it matches with the I_{mp}^* and the maximum power is transferred to the load at that point.

Reference Cell Based algorithm-Method 2

- One thing we need to remember is that the output of the op-amp and multiplier are both voltages but proportional to short circuit current and current at maximum power point respectively.
- These were the reference cell based algorithms .
- Let us look at some of the non-reference cell based algorithms.
- The following block diagram shows one such algorithm.

Reference Cell Based algorithm-Method 3

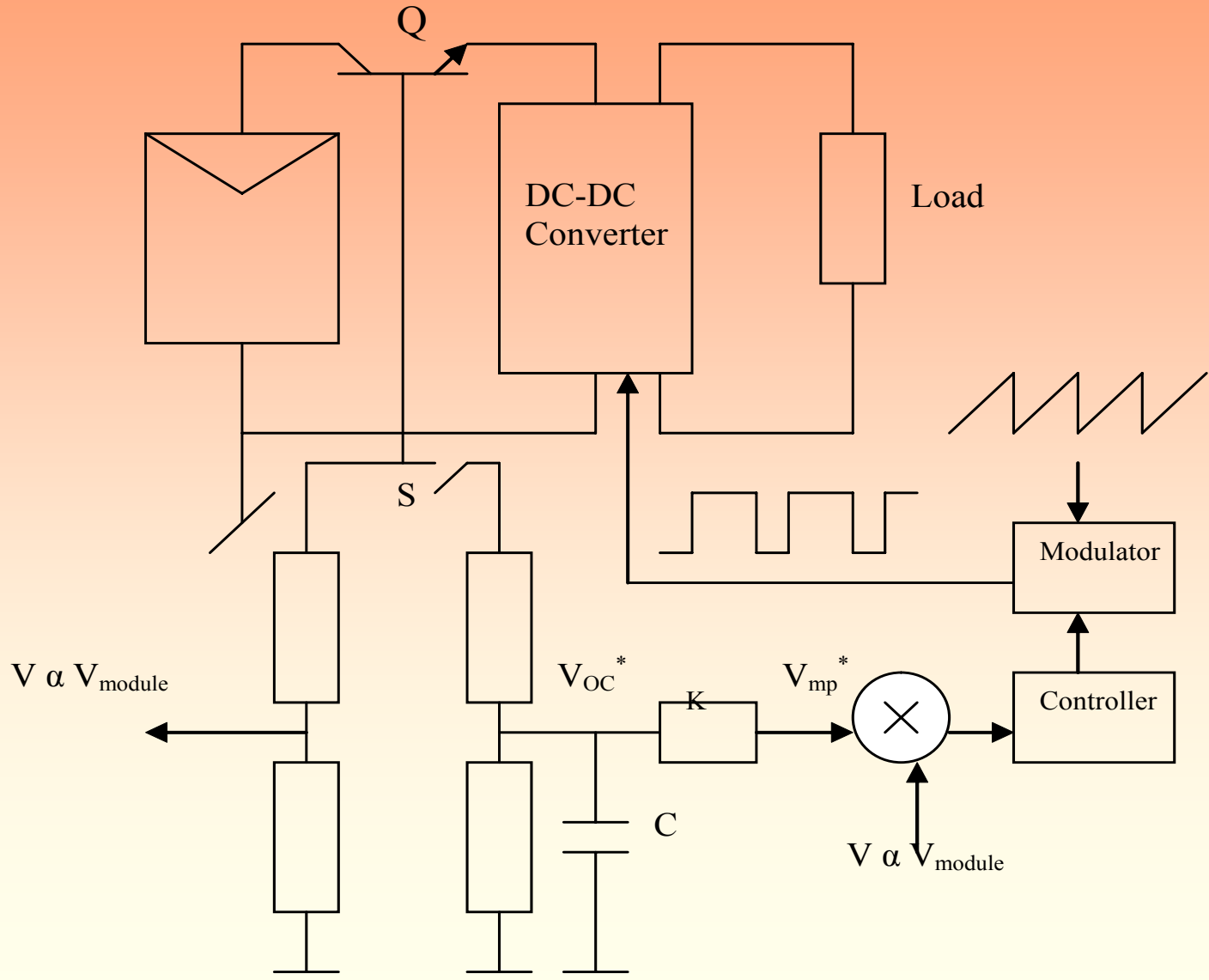

Reference Cell Based algorithm-Method 3

- The sense voltages should be connected to module terminal voltage.
- During the period when open circuit voltage is to be sensed, S is closed and Q are opened.
- This will disconnect the power conditioner and load from the module.
- The capacitor voltage will charge up to V_{oc} .
- Then S is open and Q is closed for normal operation of the module and load.
- It is be noted that the duty cycle for switching S should be very small i.e. less than 1%, so that the normal operation is not affected.

Reference Cell Based algorithm-Method 3

- The algorithm works as follows. Since there is no reference cell and still we need to have the V_{mp} value for comparison, we need to measure the V_{OC} of the same cell.
- This is done with the help of switch S. While measuring V_{OC} , we need to disconnect rest of the circuitry.
- This is done with an active switch Q. To start with, Q is opened and S is closed for a short while.
- Capacitor C gets charged to a voltage that is proportional to V_{OC}
- Now, Q is closed and S is opened. A voltage V proportional to the module voltage is measured. This voltage is compared with V_{mp}^* .

Reference Cell Based algorithm-Method 3

- If these two voltages match, maximum power is transferred to the load through the DC-DC converter.
- If the voltages do not match, then an error signal is generated.
- Depending on the polarity of the error signal, duty cycle is increased or decreased such that the voltages match.
- This method is much more accurate than the earlier two methods since we are measuring the open circuit voltage of the module that we are using in the application and hence comparing the voltage at the maximum power to the voltage of the module .
- A small price we are paying for the improved accuracy is the power losses in the switches.

Reference Cell Based algorithm-Method 4

- An improved algorithm compared to the previous one is shown in the following block diagram.
- We do not have switches in this method and hence no losses due to the switches.
- This method is based on the P-V characteristics of the module.
- We know that the value of the power increases with an increase in the voltage up-to a point that we call as the maximum power point.
- Power beyond this point decreases with an increase in the module voltage.
- In the region where the power is directly proportional to the voltage, power and voltage have same phase and in the region where the power is inversely proportional to the voltage, they are in opposite phase.

Reference Cell Based algorithm-Method 4

- This fact is used in the algorithm for tracking maximum power point of the module. P-V characteristics shown in the following figure explains the logic.

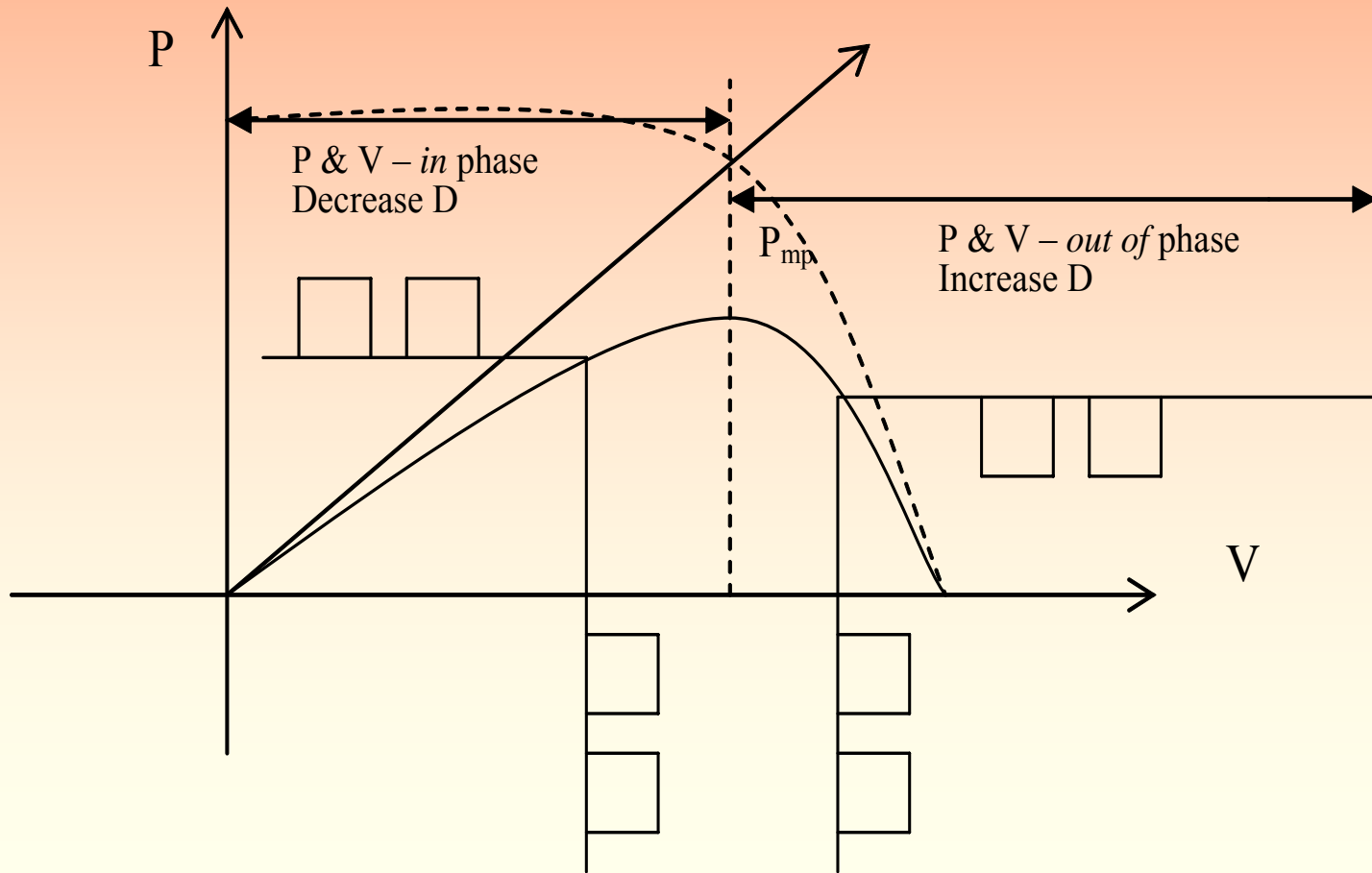

Reference Cell Based algorithm-Method 4

- The following block diagram explains the algorithm for tracking maximum power point:

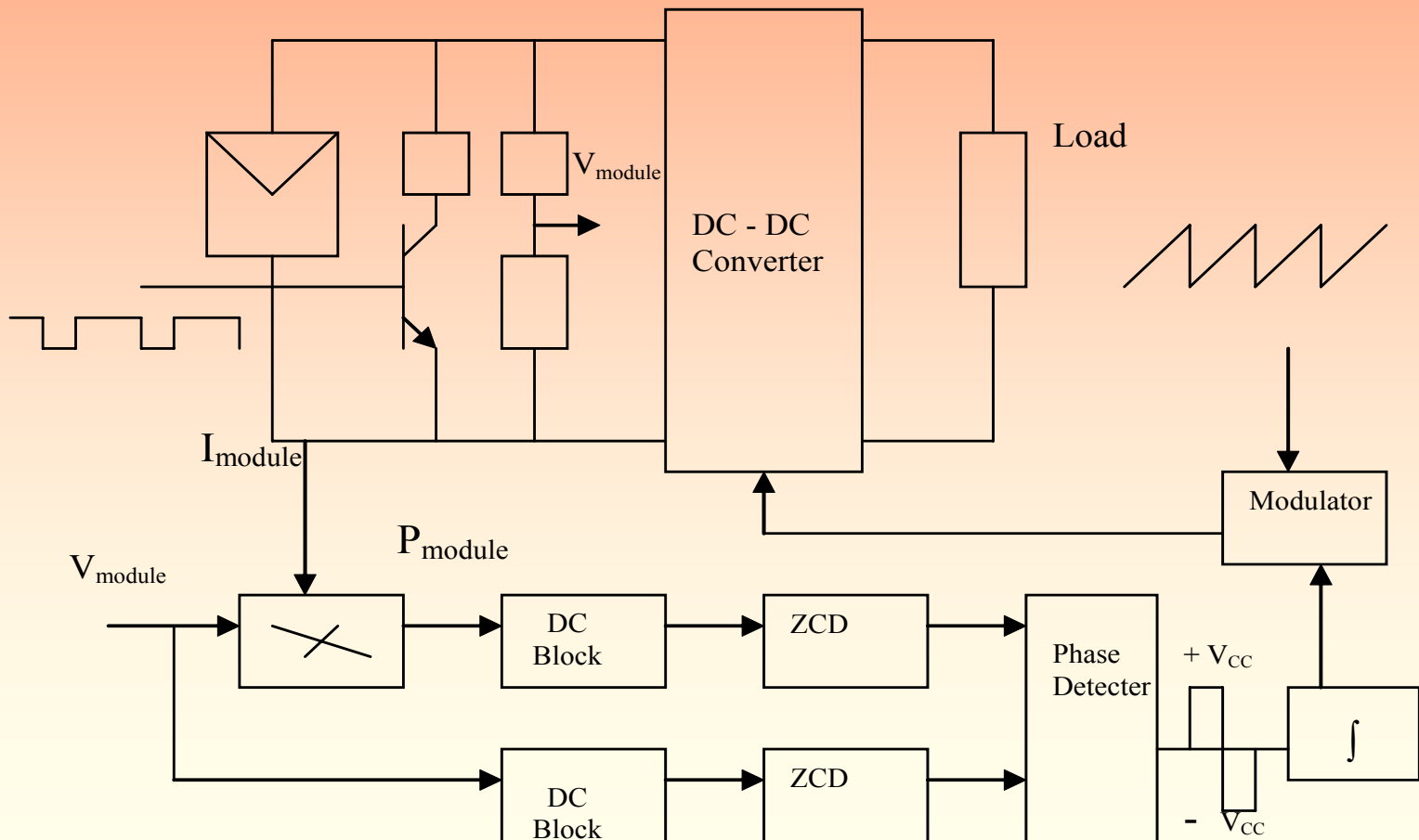

Reference Cell Based algorithm-Method 4

- A rectangular pulse is given at the base of the transistor.
- A voltage proportional to the voltage of the module is fed into a multiplier.
- This voltage has both dc component of the module over which an ac rectangular pulse is riding.
- Current from the module is also fed into the multiplier.
- The output of the multiplier is the power P of the module.
- This signal also has the ac rectangular pulse riding on a dc value.

Reference Cell Based algorithm-Method 4

- It is be noted that the duty cycle for switching S should be very small i.e. less than 1%, so that the normal operation is not affected.
- This is fed to the zero crossing detector (ZCD).
- The output of the detector is either a $+V_{CC}$ or a $-V_{CC}$ depending on the pulse.
- If the pulse is positive, the output of the ZCD will be $+V_{CC}$ and if the pulse is negative, the output of the ZCD is $-V_{CC}$.
- This is fed to the phase detector as one of the inputs.

Reference Cell Based algorithm-Method 4

- Following block diagram explains the working of the ZCD:

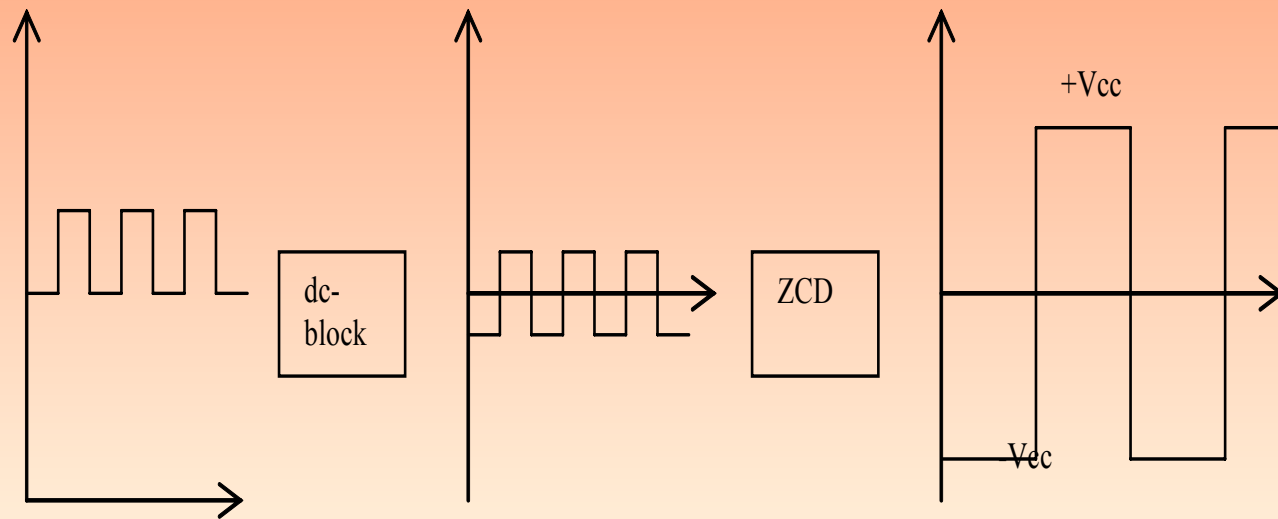

- The voltage from the module is fed to another dc block. The output of which is an ac rectangular pulse.
- This is fed to the ZCD. Similar to the earlier case, the output could be a $+V_{CC}$ or a $-V_{CC}$.

Reference Cell Based algorithm-Method 4

- This goes as a second input to the phase detector.
- Phase detector compares the phases of the power signal and the voltage signal.
- If the phases of both power and voltage signals are in phase, the output of the phase detector is $+V_{CC}$ and if the phases are opposite to each other, the output of the phase detector is $-V_{CC}$.
- The signal from the phase detector is fed to an integrator and then to a modulator to vary the duty cycle D .
- This is fed to the DC-DC converter.

Reference Cell Based algorithm-Method 4

- The value of D is decreased if the phases of power and voltage are same and the value is increased if P and V is in opposite phase.
- Once the D value changes, the load line changes and if it matches with the load line of the module at maximum power point, then maximum power is transferred to the load.

Reference Cell Based algorithm-Method 5

- This method is based on the previous one where we had used the PV characteristics.
- Here, instead of comparing the phase of power with the phase of the voltage, we are going to compare two levels of power.
- The source for two levels is the same, the power of the module.
- However, this power is made to go through two different RC networks making them to respond at two different levels.
- If we call one level as P_{slow} and other level as P_{fast} , we can have an algorithm that compares these two power levels and changes the duty cycle of the DC-DC converter.

Reference Cell Based algorithm-Method 5

➤ Following block diagram shows the algorithm.

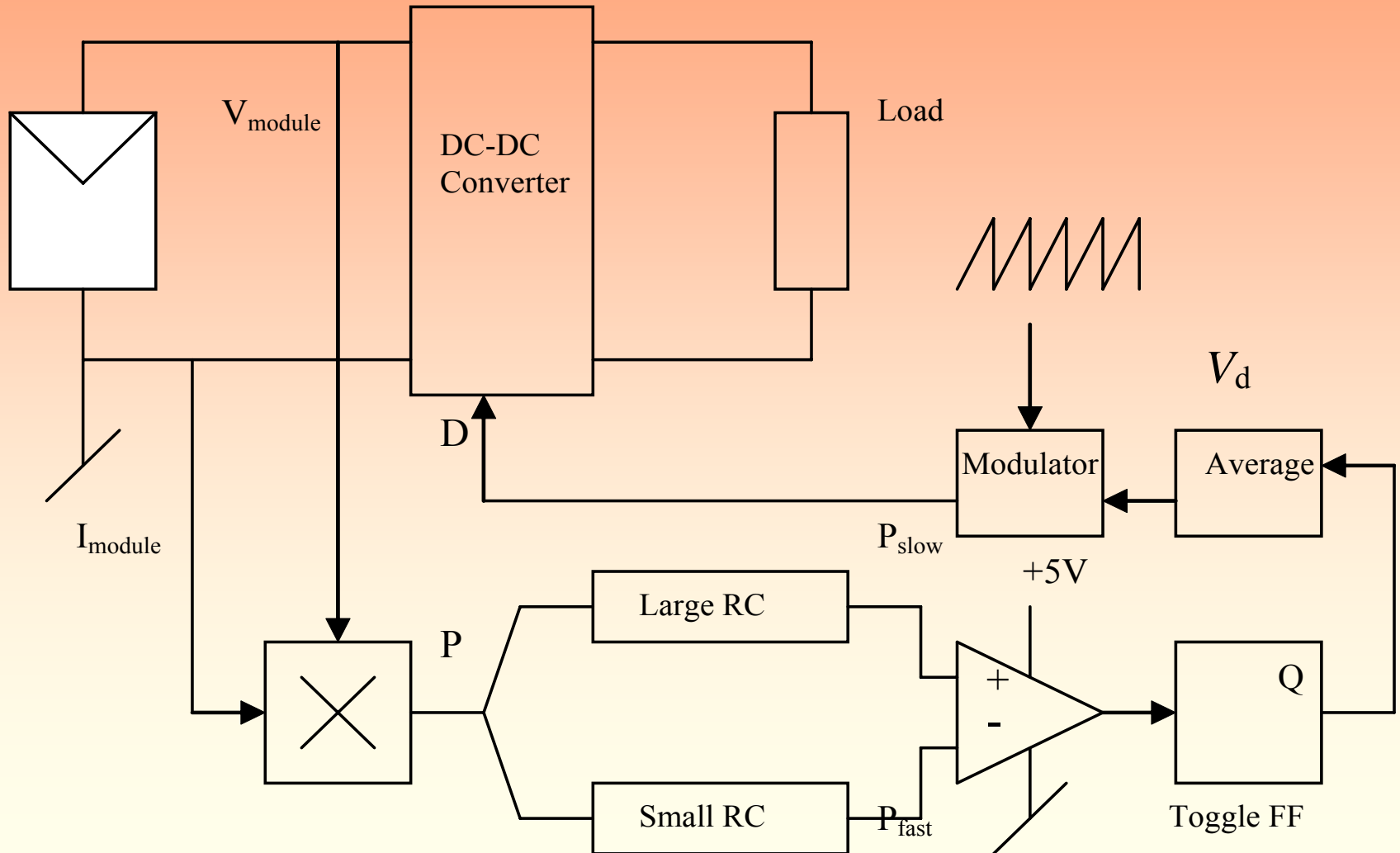

Reference Cell Based algorithm-Method 5

- Voltage and current of the module are fed to a multiplier resulting in the power of the module.
- This power is fed through two different RC networks, one having a small RC value giving faster response and the second one with the large RC values giving slower response .
- Let us call the faster response power as P_{fast} and the slower response power as P_{slow} respectively.
- These two values are fed to a differential amplifier, the input to the amplifier being $(P_{\text{slow}} - P_{\text{fast}})$.

Reference Cell Based algorithm-Method 5

- To understand the algorithm further, let us re-visit the P-V characteristics of the module shown in the following figure:

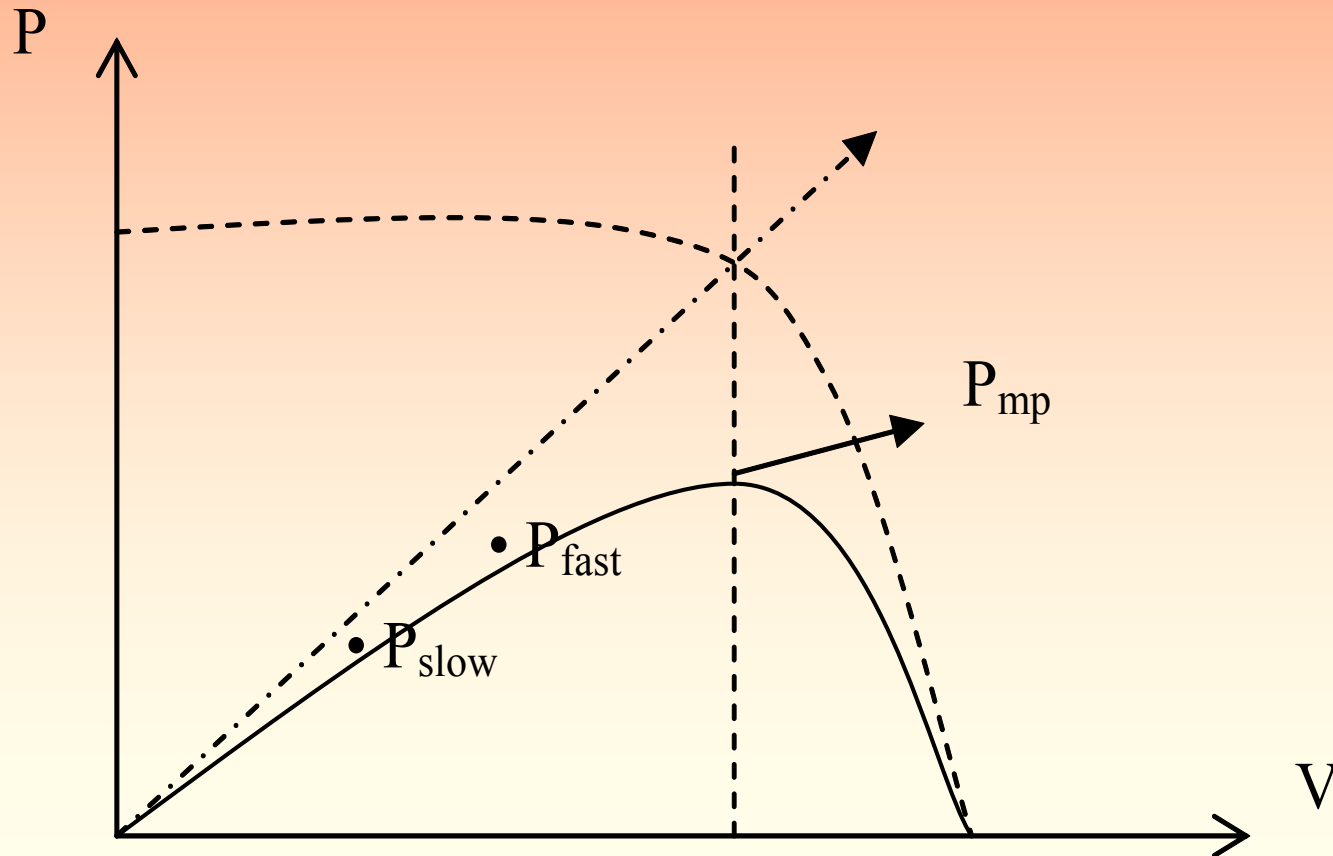

Reference Cell Based algorithm-Method 5

- To the left of the peak power point, when the voltage increases and D value decreases.
- there will be two values of power, P_{fast} and P_{slow} . P_{fast} is going to be a higher value compared to P_{slow} .
- The difference is going to be negative. As the voltage is further increased, the value of P_{fast} increases till it reaches P_{mp} and then starts decreasing beyond that point .
- A point is reached at which P_{slow} would have a higher value compared to P_{fast} .
- The net difference at this point would be positive.
- This would trigger the positive edge triggered toggle flip-flop changing its output state.

Reference Cell Based algorithm-Method 5

- If the output was initially high, it would go to a low state decreasing the average value of the flip flop.
- This changes the modulator output resulting in increase in the duty cycle D .
- The increase in the D value would decrease the voltage, decreasing the power.
- Again, P_{fast} value would be higher than P_{slow} and the net input to the differential amplifier would be a negative value.
- At this point, both P_{fast} and P_{slow} are on the right of P_{mp} point.

Reference Cell Based algorithm-Method 5

- When P_{fast} crosses over to left of P_{mp} , a point is reached when value of P_{slow} would be higher than P_{fast} , resulting in a net positive value, triggering the flip flop.
- The output of the flip-flop goes high state now, increasing the average value.
- This decreases the duty cycle. This increase and decrease of D value goes on till P_{fast} and P_{slow} crosses on each other around the P_{mp} point.
- At this point, maximum power from the solar module is transferred to the load.

Reference Cell Based algorithm-Method 5

- The wave forms at the output of each stage are shown in the following figures:

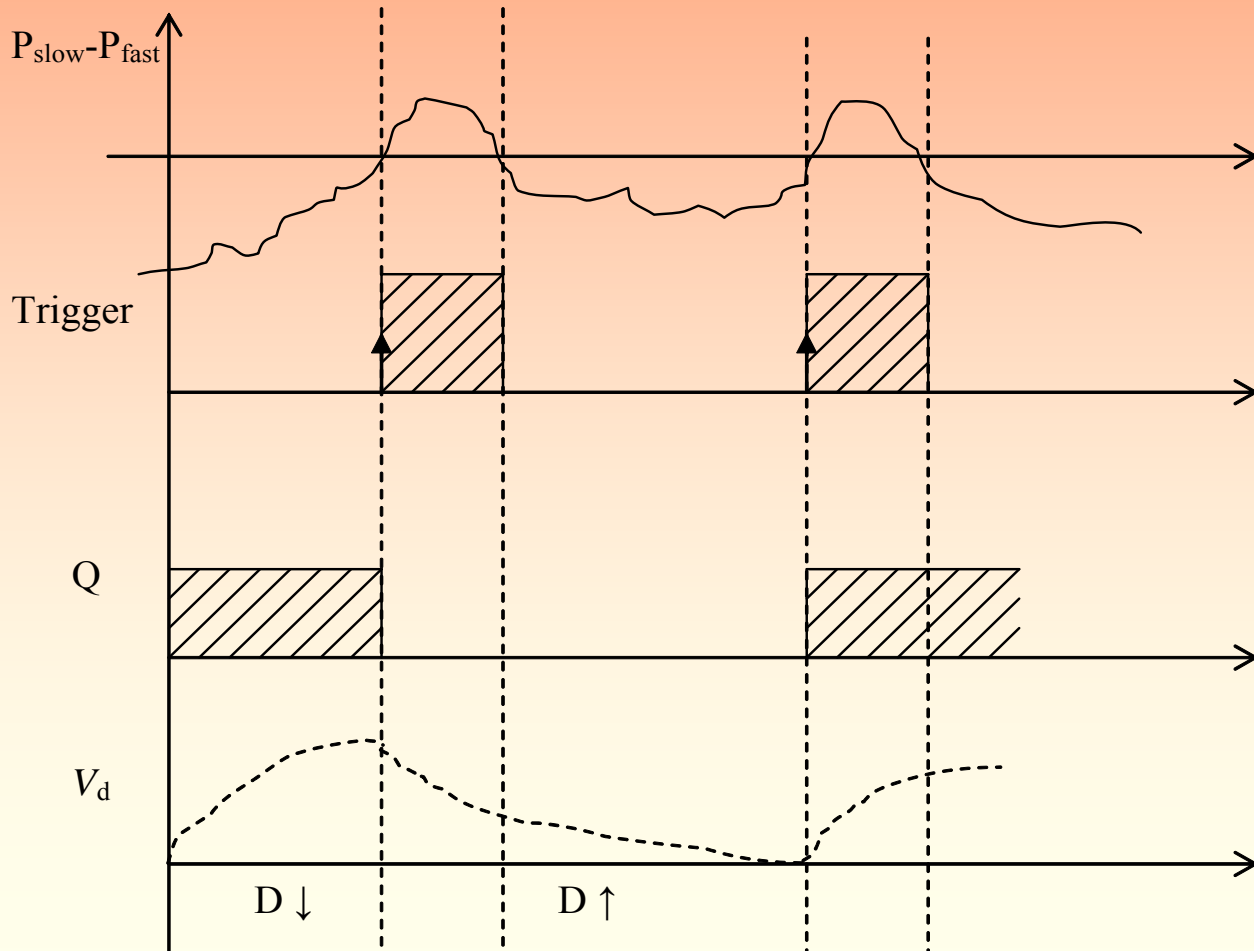

Energy Storage

- We have seen how photovoltaic energy can be generated and transferred to a load.
- We have also seen how to track maximum power point of a solar module so that maximum power can be transferred to the load.
- Availability of photovoltaic energy depends on the availability of the source, the Sun.
- This means, any application based on photovoltaic energy can be utilized only when the sun light is available unless we can store the solar energy in some form and then use it in the absence of sun light.

Energy Storage-1

➤ Following table provides a list of storage devices, storage mechanism, releasing mechanism and their efficiency:

Sl. No	Storage Device	Storage Mechanism	Releasing Mechanism	Efficiency
1	Battery	Electro-chemistry	Electro-chemical	70%
2	Potential of lifted water/fluid	Pumps – dc, ac, centrifugal	Water turbine, alternator, dc generator	80%
3	Compressed air/fluid	Air compressor	Gas turbine, alternator, dc generator	70%
4	Inertias – Flywheel	Motors – ac, dc; Springs	Generator – ac, dc	70%-80%

Energy Storage-2

Sizing of Battery:

- Size of battery is classified in terms of charge it holds. The stored energy in a battery is given by the following expression

(Watt-Hour) and

$$\text{Charge} = \frac{Whr}{V} = Ahr$$

- Since voltage is almost constant in a battery, Ampere-Hour is used as a basic unit in classifying a battery.
- Two terms one needs to know about battery are:
- Depth of discharge (DOD): Depth of charge withdrawal.
- State of charge (SOC): This is the amount of charge left in the battery.

Energy Storage-3

- We have to be aware of the allowed DOD for any battery since there is a good possibility of destroying a battery permanently if it is discharged to a level below DOD specified for the battery.
- The following figure explains the meaning of the term depth of discharge:

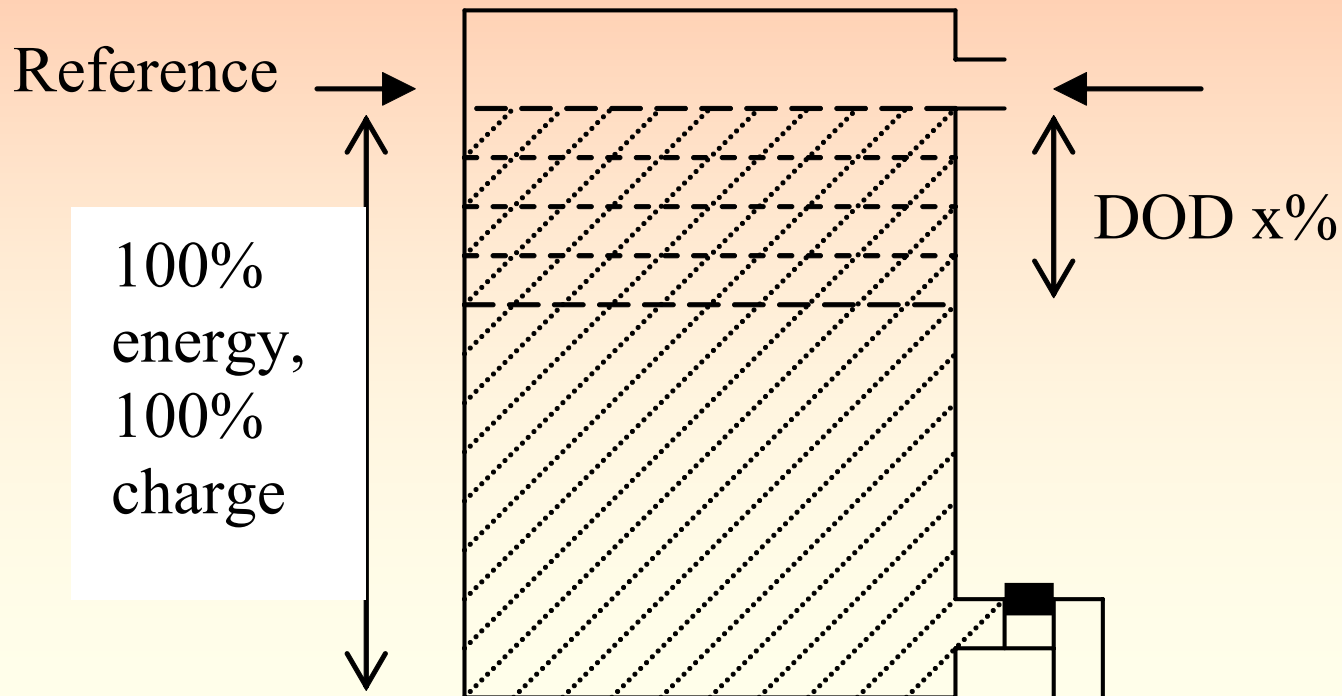

Energy Storage-4

- Any rechargeable battery is charged 100% for the first time.
- While using the battery after initial charge, one has to be aware of DOD rating of the battery so that it is not discharged below that level.
- DOD rating of the battery depends on the type of battery. Following are the types of batteries commonly used:

SLI battery:

- It is an abbreviation for **S**tarter, **L**ighting, **I**gnition batteries.
- From the name itself we can say that they must have been designed to be used in automobiles.
- They are valve regulated batteries.
- They have very high power density but low energy density.

Energy Storage-5

Tubular battery:

- These are deep discharge batteries having a DOD of 80%.
- They have very low power density but very high energy density.
- These batteries can be used for a longer period since the depth of discharge can go up to 80%.

Capacity of battery:

- Capacity of battery gives the energy storing capacity of a battery.
- The actual capacity is measured in watt-hours (Whr). Since the voltage across the battery is normally constant, the capacity is given in amp-hours (Ahr), commercially.

Energy Storage-6

- Normally, the batteries are marked as C_{10} , C_5 , C_2 , C_1 or $C_{0.5}$. The subscripts 10, 5, 2, 1 or 0.5 gives the charge/discharge rate .
- In general, capacity of a battery is indicated by the notation C_x , x being the charge/discharge rate.
- The amount of current drawn can be calculated by dividing C by x.
- The following example will make it clearer in understanding the terminology.
- If we have a battery denoted by C_{10} , having a capacity of 40 Ahr, then $(40/10) = 4$ Amps of current can be drawn from such a battery for 10 hours.

Energy Storage-7

- Following graph explains the battery usage.

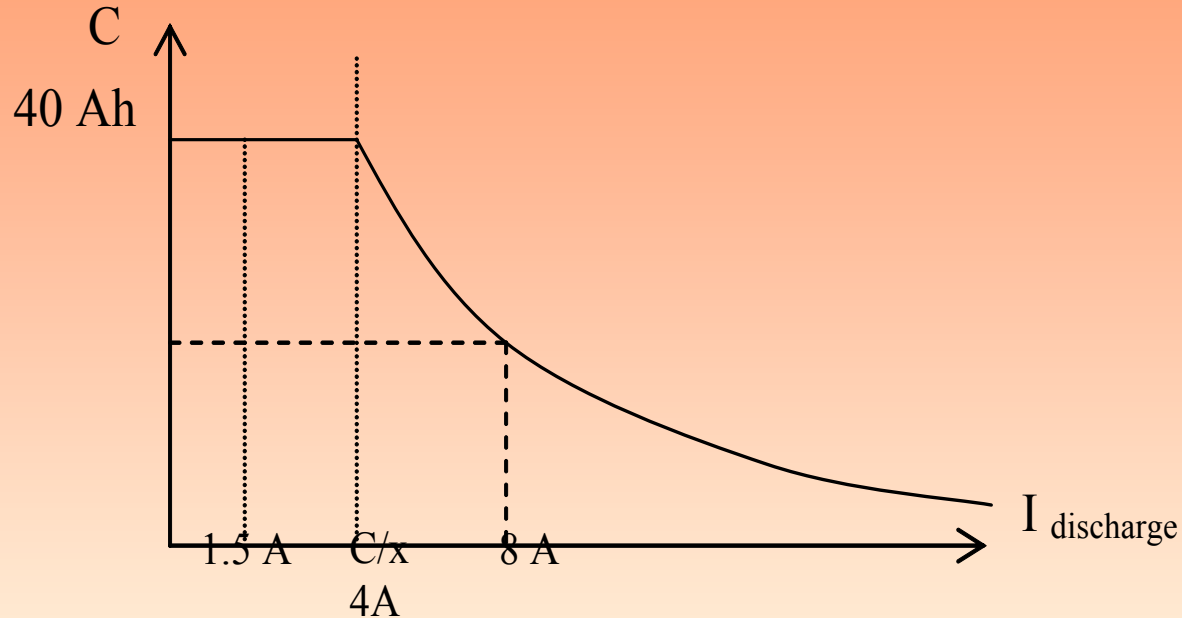

- As long as we draw C/x amps from a C_x battery, we are not harming the battery.
- The capacity of the battery remains constant.
- But if the current drawn is more than C/x amps, we see the deterioration in the capacity of the battery.

Energy Storage-8

Life of battery:

- Life of a rechargeable battery is given in terms of number of cycles.
- One cycle is equal to one charge and one discharge.
- If a battery has life of 1000 cycles, it means that the battery can be charged 1000 times and discharged 1000 times.
- After 1000 times, no matter what you do, the cell will not get charged.

Energy Storage-9

Charge controller:

- To understand the need for charge controller, let us re-visit the earlier section where we discussed about the capacity of the battery.
- This is an important measure of the battery. Based on the load requirement, we select the battery.
- Every battery has a depth of discharge (DOD) and depending the type of the battery, DOD may be shallow or deep.
- For most of our applications, we can assume the DOD to be about 40%.
- The watt-hour size of the battery is obtained by dividing watt-hour required by the DOD value.

Energy Storage-10

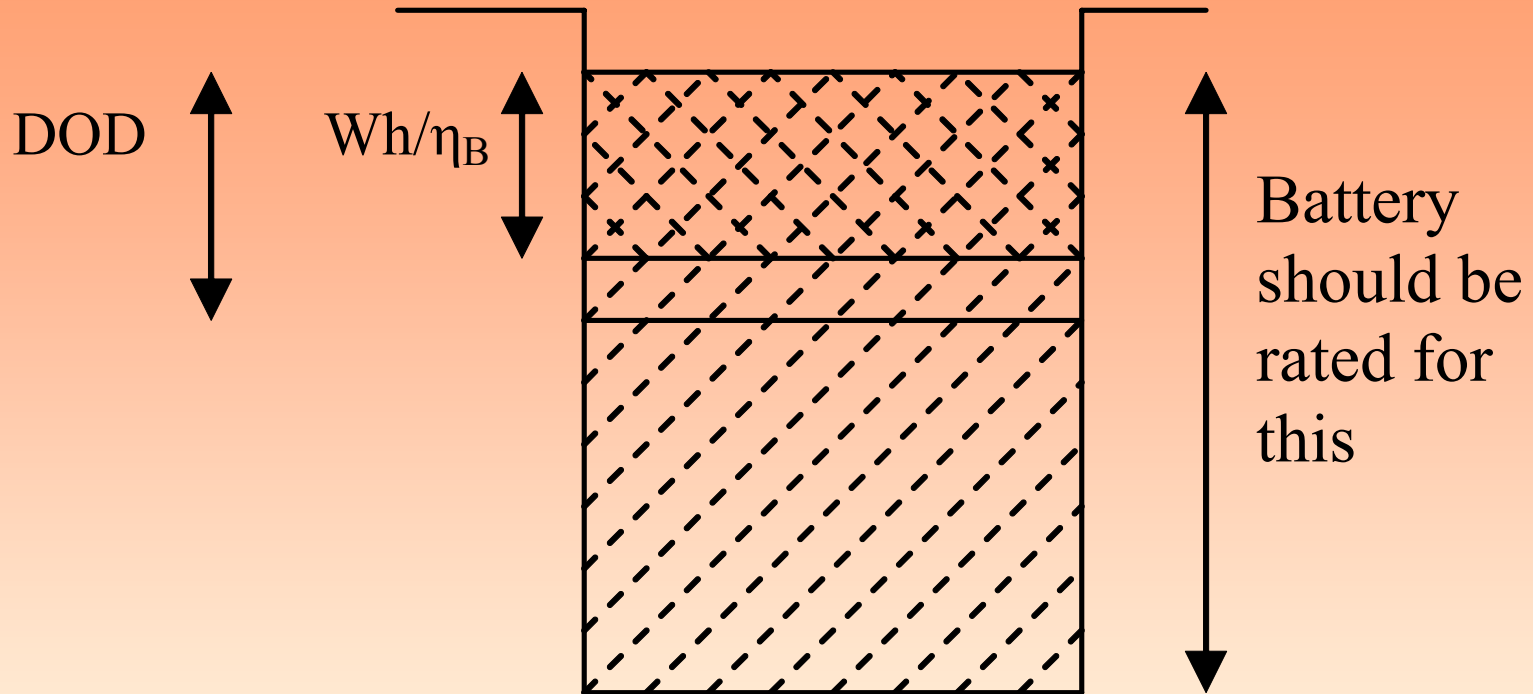

➤ As we have seen in the earlier section, commercially the capacity of the battery is given in Ahrs and it is equal to:

$$C = \frac{\left(\frac{Wh_{required}}{\eta_B} \right)}{DOD \cdot V_{Bno\ min\ al}} \quad \text{Ahrs}$$

Applications

PUMP:

- Let us consider the following application where a DC motor is connected to PV panel on one side and some load such as a pump on the other side as shown in the following figure:

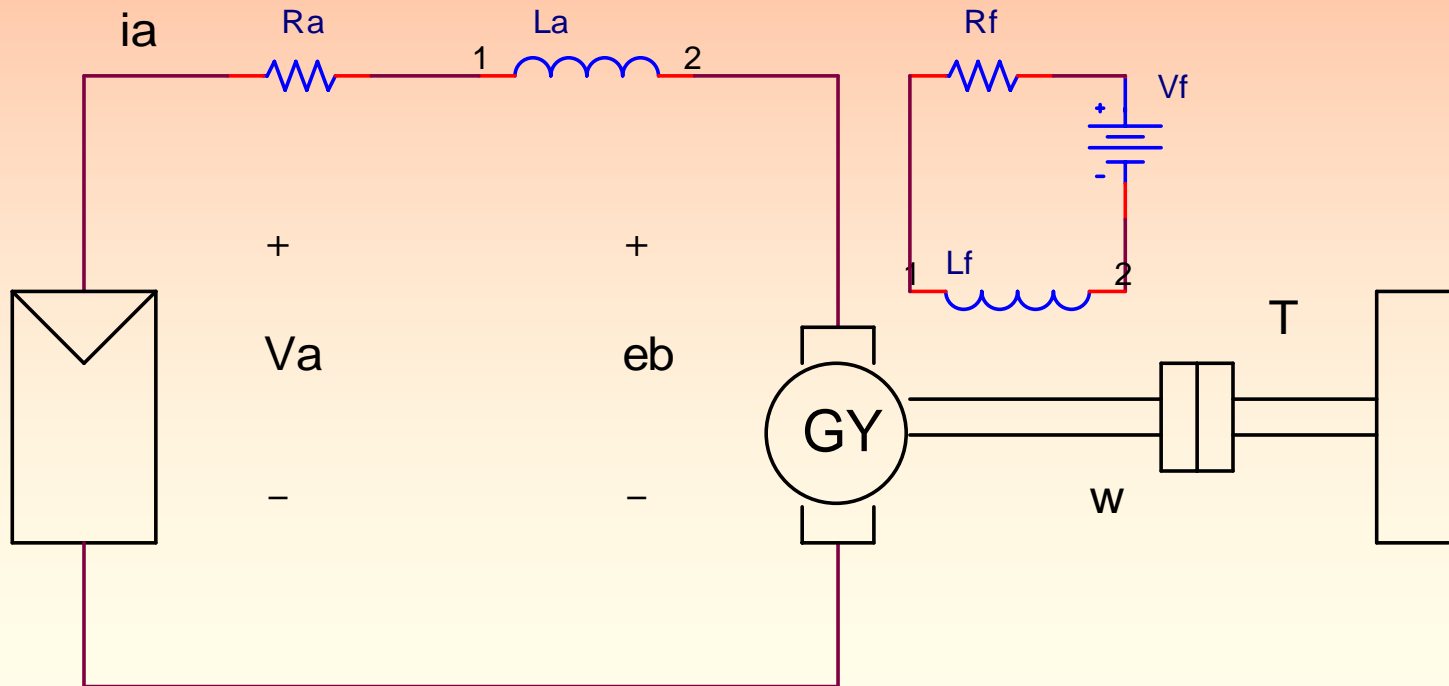

Applications-1

- R_a represents the armature resistance of the motor.
- L_a represents the armature inductance of the motor.
- e_b is the back emf developed across the motor.
- V_a is the voltage developed across the armature of the motor.
- L_f is the inductance of the field coil.
- R_f is the resistance of the field coil .
- V_f is the voltage source for the field coil.
- Field coil is used to excite the motor resulting in constant flux.
- T represents the torque developed by the motor and ω the angular velocity of the shaft connected to the pump.

Applications-2

- The DC motor works as a Gyrator.
- To understand the concept of gyrator first we need to understand the concept of a transformer.
- If we call voltage as an effort and current as flow, in a transformer, effort on the primary side is related to the effort on the secondary side as a multiple by a constant depending on the turns ratio of the transformer.
- Similarly, the flow on the primary side is related to the flow on the secondary side as a multiple by a constant again, depending on the turns ratio.
- If we call the primary side as input and the secondary side as the output then we see that input effort is related to the output effort and input flow is related to the output flow.

Applications-3

- This is the concept of a transformer. In a gyrator, the relationships are different.
- The effort on the input side is related to the flow on the output side and the effort on the output side is related to the flow on the input side.
- let us consider the DC motor. For a DC motor, e_b is the input effort, I_a is input flow, T is the output effort and ω is the output flow.
- let us look at some of the relationships for a DC motor. The first relation ship is given by:

$$T_d \propto \phi \cdot I_a$$

$$T_d = K \cdot I_a$$

where K is a constant proportional to constant flux.

Applications-4

- Here, T_d is the output effort and I_a is the input flow. We see a cross relationship. Let us see the second relationship given by:

$$\omega \propto \frac{e_b}{\phi} \quad \omega = \frac{e_b}{K}$$

where K is a constant proportional to constant flux.

- Here, e_b is the input effort and ω is the output flow. We again see a cross relationship. Hence, we can see that the DC motor is a gyrotor.
- For the above circuit, we can write the following relationship:

$$v_a = i_a \cdot R_a + e_b$$

Applications-5

- v_a is the voltage across the PV panel and i_a is the current from the panel. Substituting equations (2) and (4) in equation (5), we get the following expression:

$$v_a = \frac{T_d}{K} \cdot R_a + K \cdot \omega$$

- Here T_d is the load torque required at the motor shaft. From equation (2), this depends on the panel current.
- The corresponding panel voltage needed can be obtained from the V-I characteristics of the panel as shown in the following figure:

Applications-6

V-I characteristics

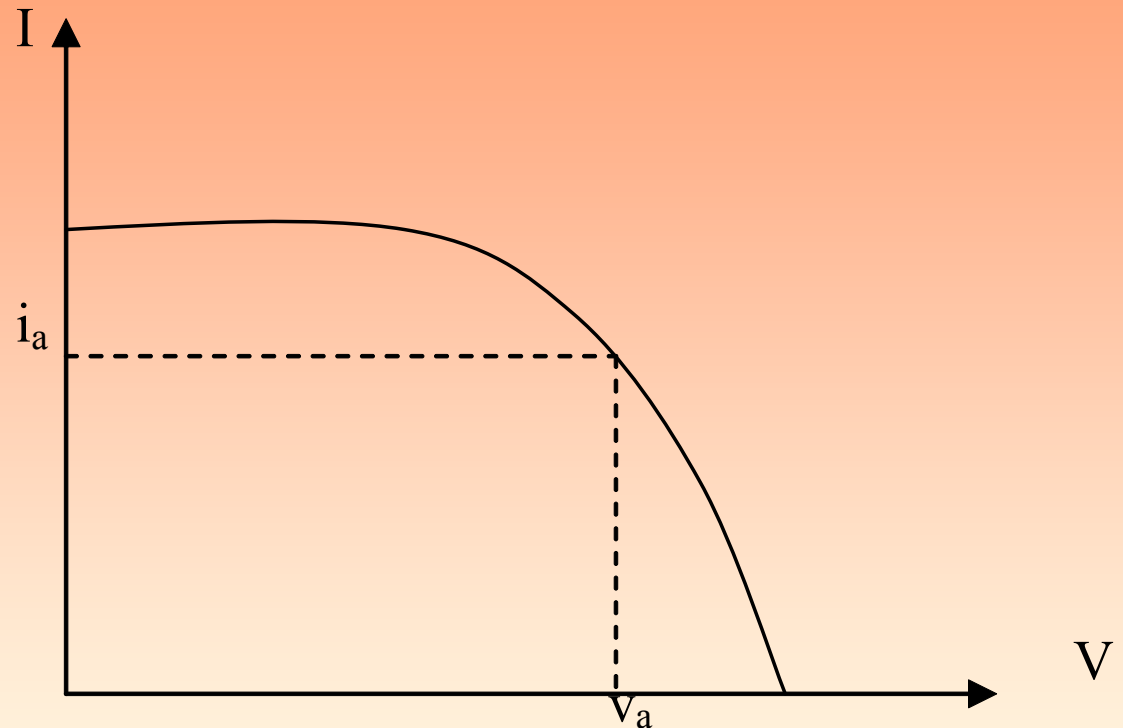

From equation (4), we have seen that the angular velocity of the shaft is related to the back emf, e_b developed at the motor.

Re-arranging equation (5), we can write the expression for e_b as:

$$e_b = v_a - i_a \cdot R_a$$

Applications-7

- Here, we can see the relationship between e_b and v_a . Equation (4) gives an important relationship between e_b and ω that specifies e_b required for the desired speed of the motor. From the equations (4) and (7), we would know v_a required for desired speed of the motor.
- It is clear from the above discussion that DC motor takes electrical input and delivers mechanical output.
- This output may be used for driving a load such as a pump.
- Hence, in a big picture, we need to match the characteristics of the PV panel providing the electrical input to the characteristics of the load that is being driven by the mechanical output.
- The parameters describing the characteristics of the panel are voltage and current.

Applications-8

- The parameters describing the characteristics of the load are torque and angular velocity or speed.
- The following figure explains how we match the characteristics of the source and load.

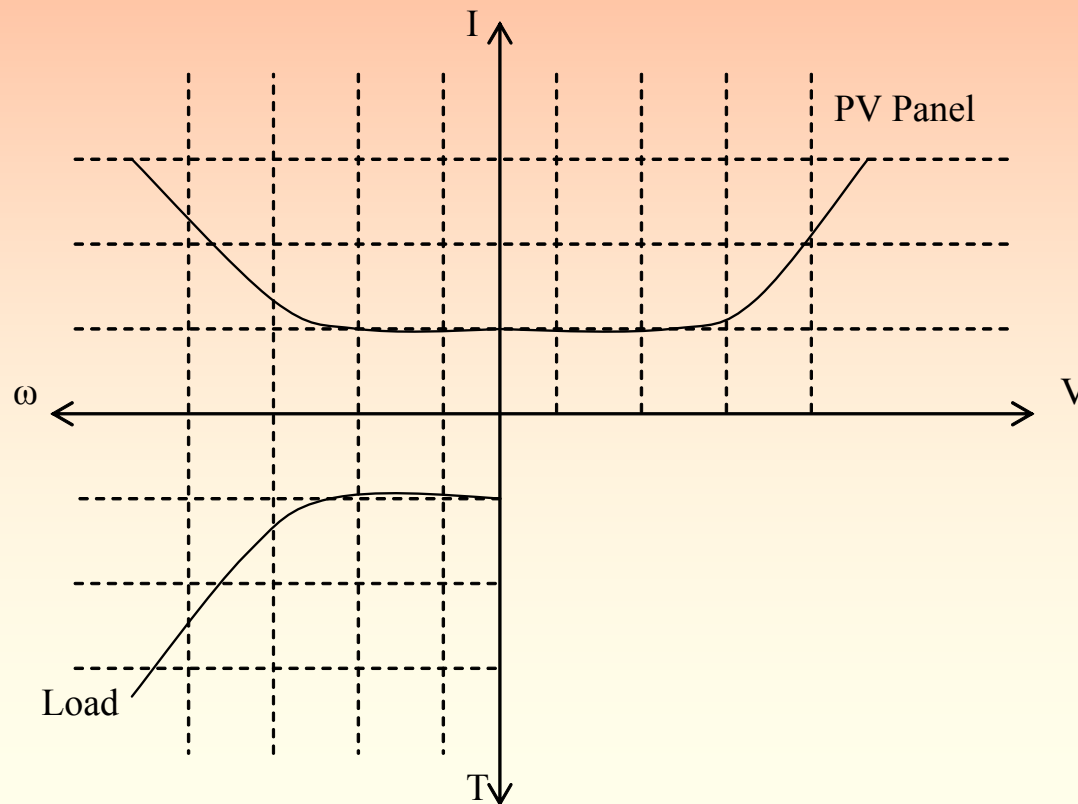

Applications-9

- We see the load characteristics in the third quadrant given as a function of torque (T) and the speed (ω).
- This characteristic is translated into second quadrant using equation (2) that relates torque to the current.
- This characteristic is superimposed on the characteristics of the PV panel to do the matching, as shown in the following figure:

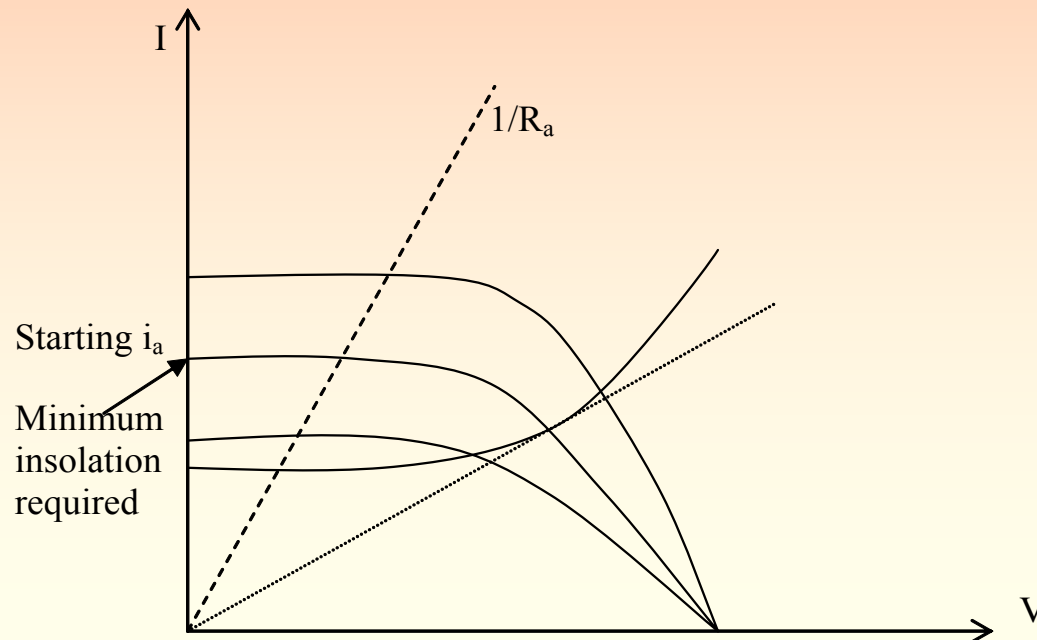

Applications-10

- When the motor is at rest, it does not have e_b . Hence the current required for starting the motor can be obtained from equation (5) by substituting $e_b = 0$.

$$i_a = \frac{V_a}{R_a}$$

- The point indicated by the arrow gives the minimum insolation required for producing the starting current.
- This was an example where the characteristics of the PV panel were matched to the mechanical (rotational) characteristics of the load.

Applications-11

- Following table gives the parameters describing characteristics of different types of loads:

Electrical	Mechanical (Linear)	Mechanical (Rotational)	Hydraulic
Voltage	Force	Torque	Pressure
Current	Linear velocity	Angular velocity	Rate of discharge

Pumps

- We had seen briefly how the characteristics of PV panel are matched to the characteristics of a load such as a pump.
- Let us know about the pump itself now. Pumps are of two types, reciprocating and centrifugal.
- Reciprocating pumps have positive displacement and the rate of discharge does not depend on the height to which the water has to be lifted.
- Centrifugal pumps have dynamic displacement. Its rate of discharge is a function of height to which the water has to be lifted. Let us take these pumps in little more detail:

Reciprocating Pump

- Following figure shows the working of the pump:

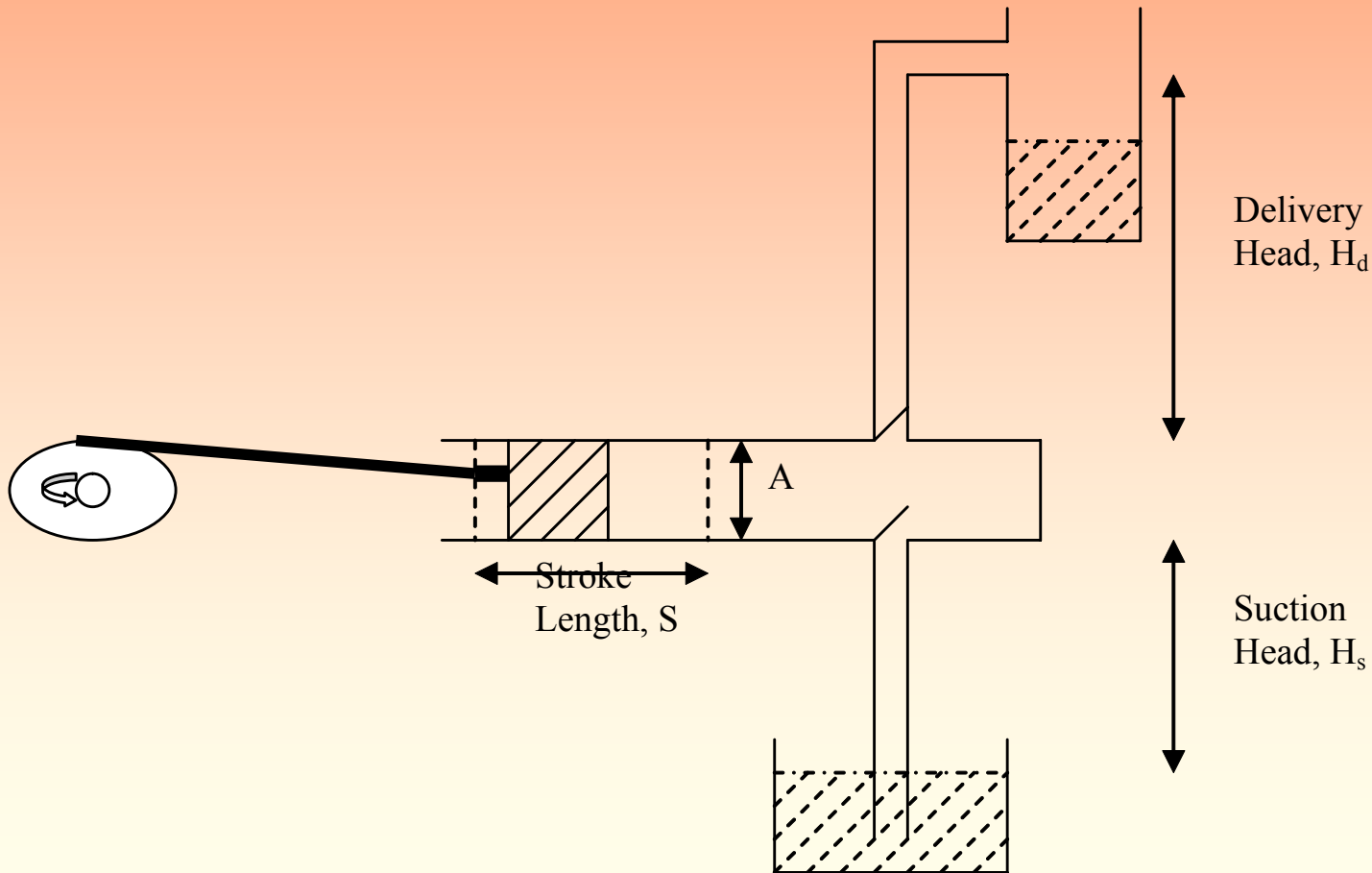

Reciprocating Pump-1

- In the figure, A is the cross sectional area and S is the stroke length. If ω is the angular velocity then the rate of discharge is given as:

$$\frac{dQ}{dt} \propto A \cdot S \cdot \omega$$

- Since area of the sectional area, and the stroke length are constants for a given piston, we can write:

$$\frac{dQ}{dt} \propto \omega$$

- We can see that the rate of discharge is independent of head.
- However, there is a theoretical limit of 10.33 meters and a practical limit of 6 meters on the suction head, H_s .
- The static head of the reciprocating pump is the sum of delivery head and suction head.

$$\text{Static Head} = H_s + H_d$$

Centrifugal Pump

- The rate of discharge of these pumps depends on the head. A simple centrifugal pump set up is shown in the following figure:

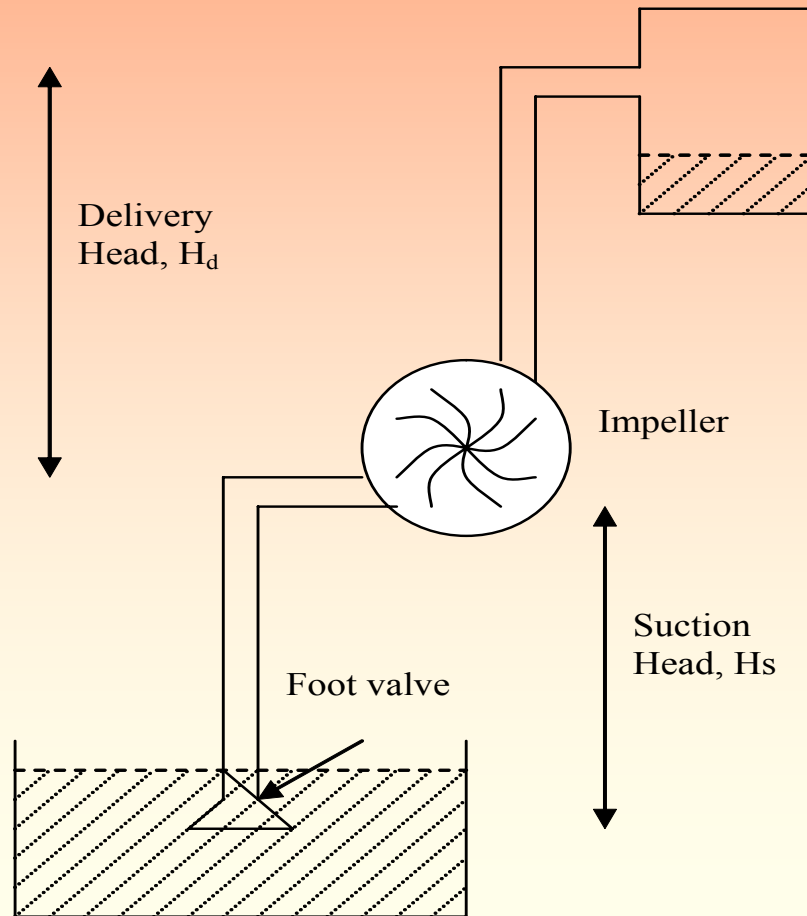

Centrifugal Pump-1

- The static head is equal to the sum of the delivery head and suction head.
- We need to know at this point the amount of energy required to pump the water overhead.
- Following block diagram gives the entire system, starting from the PV panel as source.

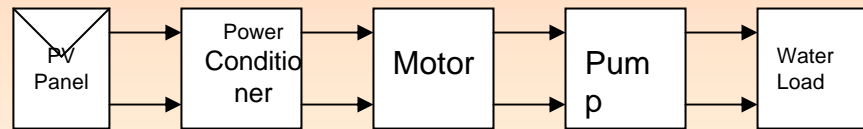

- Before we calculate the energy required, we need to know the following expressions:

$$\text{Energy} = m \cdot g \cdot h \quad \text{Joules, where}$$

$$m = \text{mass of water} = \text{Kg}$$

$$g = \text{acceleration due to gravity} = 9.81 \text{ m/s}^2$$

Centrifugal Pump-2

➤ h = height = meter

$Energy = \rho \cdot Q \cdot g \cdot h$ Joules, where

➤ ρ = density of water = Kg/m³

➤ Q = discharge = m³

➤ g = acceleration due to gravity = 9.81 m/s²

➤ h = height = meter

$Power = \rho \cdot \frac{dQ}{dt} \cdot g \cdot h$ watts, where

ρ = density of water = Kg/m³

dQ/dt = rate of discharge = m³/s

g = acceleration due to gravity = 9.81 m/s²

h = height = meter

1 Kilowatt-Hour = 1000 watts x 3600 seconds = 3.6e6 watt-second
= 3.6e6 Joules 1 m³ = 1000 liters

Peltier Cooling

- Peltier junction is normally used for applications like thermo Electric Coolers.
- The experiment aims to curve fit the characteristics of the peltier junction.
- The energy input to the peltier is the photovoltaic module of 220W.
- It is shown that a peltier junction characteristic behaves exponentially as compared to the linear fit.
- The Peltier device is a small solid-state electronic component.
- It consists of a large number of small n - and p -type semiconductor elements (generally made from bismuth telluride).

Peltier Cooling-1

- When a current is passed through the semiconductor elements, the motion of charge carriers through the material also transfers heat.
- The elements are arranged in series electrically, but are oriented so they all work together to transfer heat from the cold face of the device to the hot face.
- In addition, if a temperature difference is maintained between the two faces of the device, it will generate a voltage.
- Peltier devices can therefore be used to generate power in an external circuit if the temperature difference can be maintained.

Peltier Cooling-2

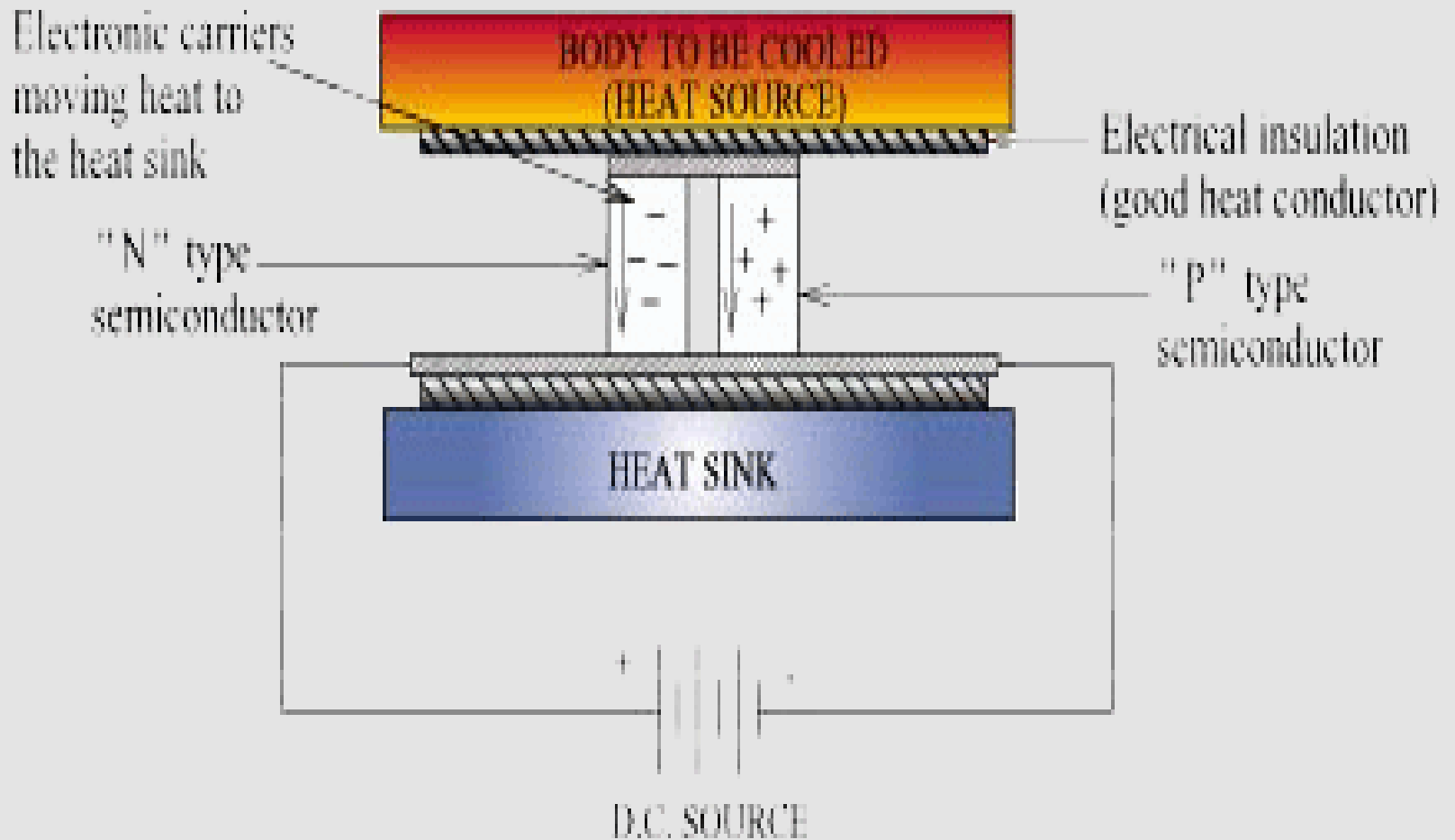

Peltier Cooling-3

Experimental Setup:

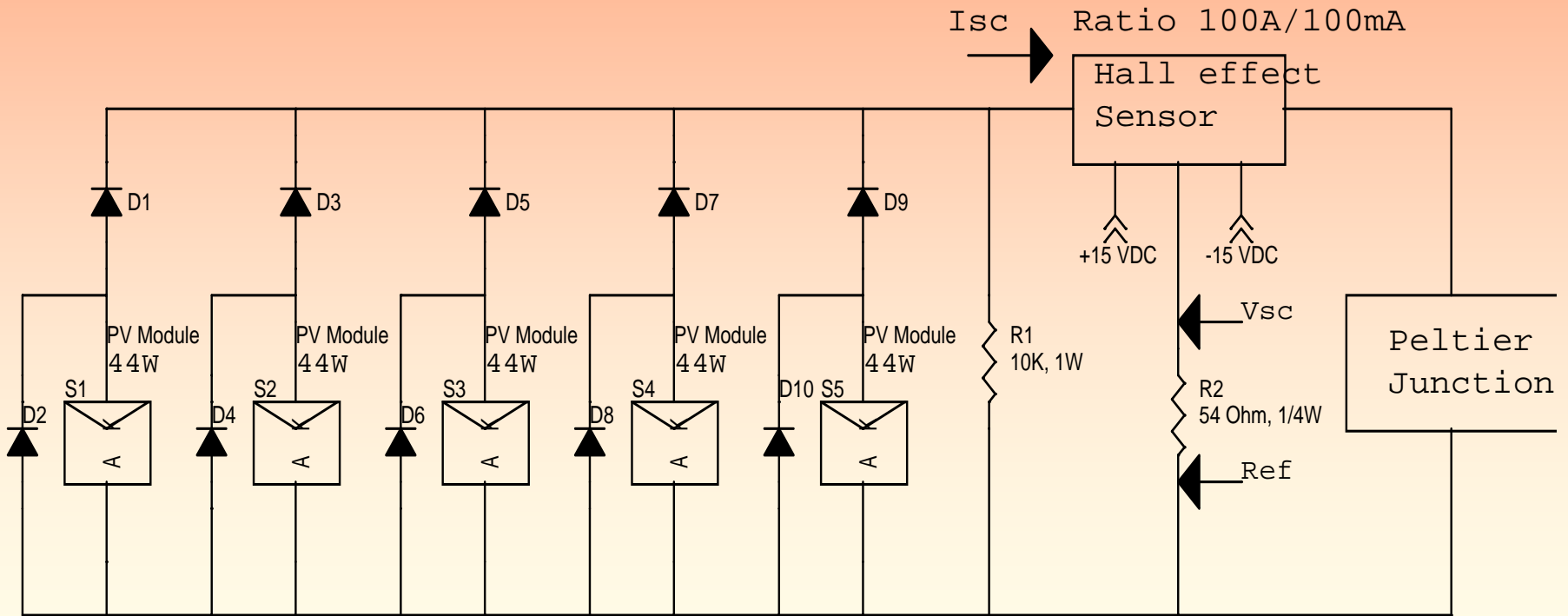

Data Analysis

- Curve fitting was done on the above data using two methods
- Linear regression &
- Exponential fit
- The scatter diagram plot along with curve fitting is shown below,

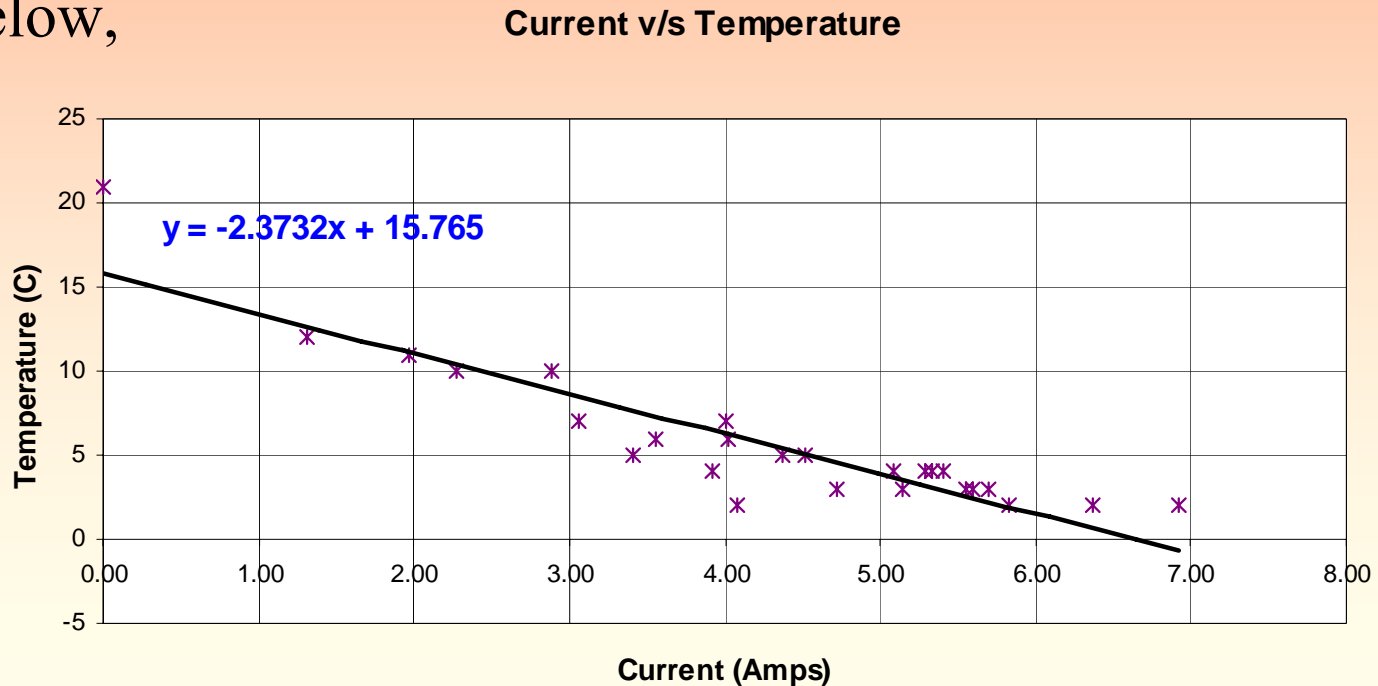

Data Analysis-1

- **Fig 1:** Plot of the data points along with the linear fit
- **Fig 2:** Plot of the data points along with the exponential fit

Current v/s Temperature

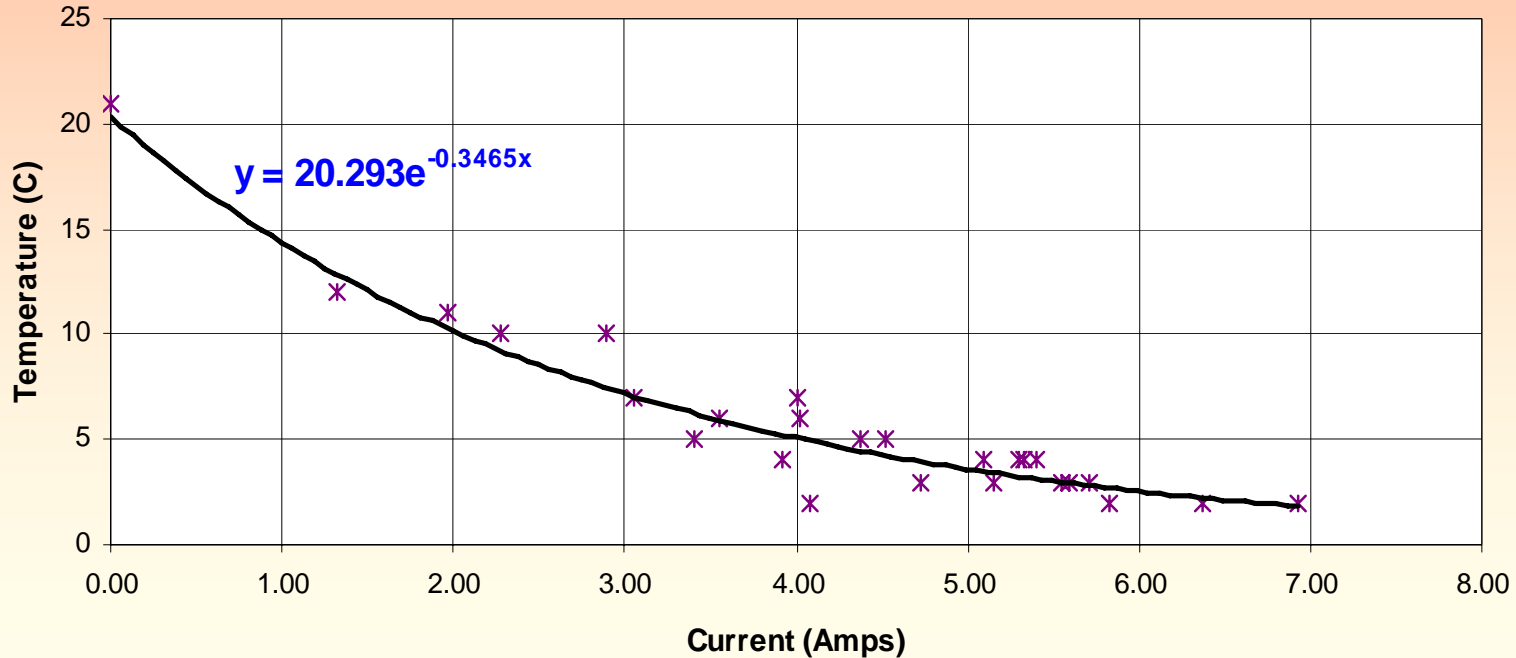

Conclusions

- The experimental data fits better with an exponential curve.
- The mean square error is less in case of the exponential fit.
- The mean square error for linear fit is 3.05 as compared to 1.15 with exponential fit.
- One of the applications of the peltier junction is TEC (Thermo Electric Coolers).
- The Cold and Hot side effect: The TEC is generally built by having Negative and Positive type semi-conductors made of bismuth-telluride, sandwiched between two ceramic plates.
- When current passes through the TEC, electrons jumping from the P type to the N type semi-conductors leap to an outer level of electrons, they absorb energy, thus "absorbing" heat.

Conclusions-1

Wattage:

- TECs measure their potential heat-dissipation in watts. Be careful though, a 156 Watt TEC will NOT dissipate 156 Watts of outside energy.
- To calculate outside heat dissipation implies complicated calculations having to deal with different Temperatures, Voltages, Amperages, insulation, etc, which is described in the advanced peltier study in article.
- Delta T (Temperature difference between hot and cold side)TECs work by pumping heat from the hot side to the cold side, but there IS a limit to this. Regular TECs have a Delta T (meaning the difference between hot and cold side) of about 68 to 70 degrees Celsius.

Lab Work

- In lab we tried to build a TEC and measure the cooling effect of the peltier junction for a given volume. The experiment was not successful due to the following reasons,
- The container enclosing the peltier junction was not air-tight.
- The container was made of metal which is a good conductor of heat.
- The proper design of the container (that is covering it with a insulating material such as thermocol, cotton wool, etc.; which is bad conductor of heat) with no air leakages can improve the efficiency of the TEC's.