

Hybrid Systems

1. Introduction

As convention fossil fuel energy sources diminish and the world's environmental concern about acid deposition and global warming increases, renewable energy sources (solar, wind, tidal, biomass and geothermal etc) are attracting more attention as alternative energy sources. These are all pollution free and one can say eco friendly. These are available at free of cost. In India, there is severe power shortage and associated power quality problems, the quality of the grid supply in some places is characterized by large voltage and frequency fluctuations, scheduled and un scheduled power cuts and load restrictions. Load shedding in many cities in India due to power shortage and faults is a major problem for which there is no immediate remedy in the near future since the gap between the power demand and supply is increasing every year. This led to rapid usage of stand-by petrol or diesel generator sets and conventional battery inverter sets in both urban and rural areas. Shopkeepers, house owners and offices commonly use 1-5 kW fuel generators in India when utility exercises load shedding.

In India wind and solar energy sources are available all over the year at free of cost whereas tidal and wave are costal area. Geothermal is available at specific location. To meet the demand and for the sake of continuity of power supply, storing of energy is necessary.

The term hybrid power system is used to describe any power system combine two or more energy conversion devices, or two or more fuels for the same device, that when integrated, overcome limitations inherent in either.

Usually one of the energy sources is a conventional one (which necessarily does not depend on renewable energy resource) powered by a diesel engine, while the other(s) would be renewable viz. solar photovoltaic, wind or hydro.

The design and structure of a hybrid energy system obviously take into account the types of renewable energy sources available locally, and the consumption the system supports. For example, the hybrid energy system presented here is a small-scale system and the consumption of power takes place during nights, so the wind energy component will make a more

significant contribution in the hybrid system than solar energy. Although the energy produced by wind during night can be used directly without storage, a battery is needed to store solar and wind energy produced during the day.

In addition to the technical considerations, cost benefit is a factor that has to be incorporated into the process of optimizing a hybrid energy system. In general, the use of wind energy is cheaper than that of solar energy. In areas where there is a limited wind source, a wind system has to be over-dimensioned in order to produce the required power, and this results in higher plant costs.

It has been demonstrated that hybrid energy systems (renewable coupled with conventional energy source) can significantly reduce the total life cycle cost of a stand alone power supplies in many off-grid situations, while at the same time providing a reliable supply of electricity using a combination of energy sources. Numerous hybrid systems have been installed across the world, and expanding renewable energy industry has now developed reliable and cost competitive systems using a variety of technologies. Research in the development of hybrid systems focused on the performance analysis of demonstration systems and development of efficient power converters, such as bi-directional inverters, battery management units (storage facilities), and optimization of different sources of energy Sources, etc.

2. Renewable Sources In India

India has a large potential for renewable energy (RE), an estimated aggregate of more than 100,000 MW. In addition, the scope for generating power and thermal applications using solar energy (since most parts of the country receive sunlight almost throughout the year) is huge. However, only a fraction of the aggregate potential in renewable, and particularly solar energy, has been utilized so far.

Table 1 Renewable energy potential & current status in India

Sources/Technologies	Units*	Potent ial	Installed capacity
Wind Power	Mwe	45 000	1 267
Small hydro (upto 25 MW)	Mwe	15 000	1 341
Biomass power	MW	19 500	308
<u>Biomass Gasifiers</u>		<u>16 000</u>	<u>35</u>
<u>Biomass</u>		<u>3</u>	<u>273</u>
<u>Cogeneration</u>		<u>500</u>	
Urban & Industrial Waste- based Power	Mwe	1 700	15.20
Solar photovoltaics	MW/sq km	20	47 MWp
Solar water heating	(million sq.m. collector area)	140	0.55
Biogas plants	Million	12	3.1
Improved cookstoves	Million	120	33

*MW - Mega Watt, sq km - square kilometer, sq m - square meter

Source: MNES Annual Report 2000-2001

3. Hybrid System

3.0 LOAD DISCRIPTION: here for the purpose of analysis a house of middle class family is taken as the load. This is around 2kW. All the hybrid system which are going to discuss is for a house or for the around 10 no of house (for big system).

3.1 Calculation For Power Output From Different Source:

3.1.0 power out put from PV array: For design of a PV system, we should know how much solar energy is received at the concern place. It is effected by sun position, could covering atmospheric affect, and the angle at which the collector is placed, called tilt angle 'β'. Normally this angle is equal to the latitude of the concern place. The related equation for estimation of the radiation is listed below [1]: -

$$1. \text{ Isolation } \quad 'i = I_0 \{ \cos \varphi \cos \delta \cos \omega + \sin \varphi \sin \delta \} \quad \text{kW/m}^2$$

$$2. I_o = I_{sc} [1 + 0.033 \cos (360N/365)] \quad \text{where } I_{sc} \text{ solar constant. } = \mathbf{1.37 \text{ kW/m}^2}$$

$$3. H_o = \int_{\omega_{sr}}^{\omega_{ss}} i \, dt \quad \omega_{sr} = \text{hour angle when sun rising}$$

$$\omega_{ss} = \text{hour angle when sun setting}$$

$$= (24/\pi) I_{sc} [1 + 0.033 \cos (360N/365)] \{ \cos \phi \cos \delta \cos \omega + \sin \phi \sin \delta \} \mathbf{kWh/m^2/day}$$

$$4. H_{oA} = \text{energy falling on the concern place considering atmospheric effect}$$

$$= K_T H_o \quad \mathbf{kWh/m^2/day} \quad \text{where } K_T \text{ dearness index}$$

$$5. K_T = A_1 + A_2 \sin (t) + A_3 \sin (2t) + A_4 \sin (3t) + A_5 \cos (t) + A_6 \cos (2t) + A_7 \cos (3t)$$

$$t = (2\pi/365) (N-80) \quad N= 1 \text{ for Jan } 1^{\text{st}}$$

$$6. A_i = a_{i1} + a_{i2} x + a_{i3} x^2 + a_{i4} w + a_{i5} w^2$$

$$\text{Where } x = (\phi - 35)$$

$$\phi = \text{Latitude in deg}$$

$$w = \text{total perceptible water vapor in atoms } \text{gm/cm}^2$$

$$7. H_t = \text{energy falling on the tilt surface at the concern place}$$

$$= R_D H_{oA} \quad \mathbf{kWh/m^2/day}$$

$$8. R_D = \text{tilted factor}$$

for the sizing the PV panel is given by[1]

$$W_{\text{peak}} = \{ 1/ h_{\text{peak}} \} [(\text{Wh}(\text{load}) * \text{No of no sun days} / (\eta_b * \text{no of discharging Days})) + \text{Wh}_{\text{load}}(\text{day}) + \text{Wh}_{\text{load}}(\text{night})/ \eta_b]$$

Where: η_b = battery efficiency

h_{peak} = no of hours for which peak insolation falls on the PV cell

3.1.1 Power Output From Wind Source:

The speed of wind is a random process; therefore it should be described in terms of statistical methods. The wind speed data were recorded near the ground surface. To upgrade wind speed data to a particular hub height, the following equation is commonly used [2]

$$v = v_i (H/H_i)^\alpha$$

Where: v -wind speed at projected height, H

v_i -wind speed at reference height, H_i

α - Power-law exponent (- 1/7 for open land).

Let

m = Mass (in kg) of the air in the hypothetical cylinder which radius is equal to the vane length

v = the velocity of air in m/s.

So kinetic energy

$$E = m u^2 / 2$$

$$\text{Power output } P_w = (v^2/2) \times dm/dt$$

$$= \rho \times (v^2/2) \times dQ/dt$$

$$= \rho \times (v^3/2) \times A$$

Where:

$Q = Au$ = volume of air

$\rho = 1.2$ (kg/m³) (at mean sea level)

$$P_w = 0.6 A u^3$$

$$p_a = P_w / A = 0.6u^3 = \text{power density (in W/m}^2\text{)} \quad [1]$$

P_w is the electrical power output of the turbine.

The available wind generator power output is a function of wind velocity v

$$P_w = \begin{cases} P_R (v^3 - v_{ci}^3) / (v_R^3 - v_{co}^3) & \text{for } v_R \geq v \geq v_{ci} \\ P_R & \text{for } v_{co} \geq v \geq v_R \\ 0 & \text{otherwise} \end{cases}$$

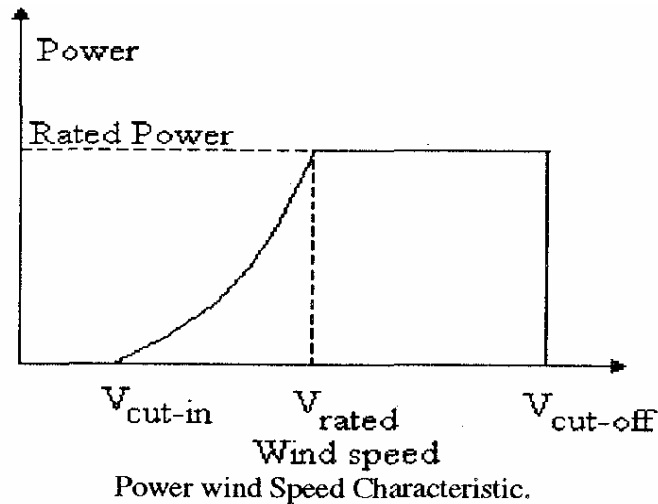

3.1.2 Calculation Of The Capacity Of The Battery Bank:

The energy generated by Hybrid system involving let say three source of energy like wind turbine and PV array for hour t ,

$E_G(t)$ can be expressed as follows:

$$E_G(t) = E_1(t) + E_2(t) + E_3(t)$$

Where: $E_i(t)$ - energy generated i^{th} source

Since it is assumed that the battery charge efficiency is set equal to the round-trip efficiency and the discharge efficiency is set equal to 1, we considered two cases in expressing current energy stored in the batteries for hour t .

If the supplied energy from all energy sources exceeds that of the load demand at a time instant, the batteries will be charged with the round-trip efficiency:

$$E_{B(t)} = E_{B(t-1)} + \{ E_{G(t)} - E_{L(t)} / \eta_{\text{charging controller}} \} \cdot \eta_{\text{Battery}}$$

Where :

$\eta_{\text{charging controller}}$ - efficiency of charging controller,

η_{Battery} - round-trip efficiency of the batteries,

$E_{B(t)}$ - energy stored in batteries in hour t ,

$E_{B(t-1)}$ - energy stored in batteries in previous hour,

$E_{L(t)}$ - load demand in hour t .

When the load demand is greater than the available energy generated, the batteries will be discharged by the amount that is needed to cover the deficit. It can be expressed as follows:

$$E_{B(t)} = E_{B(t-1)} - \{ E_{L(t)} / \eta_{\text{charging controller}} - E_{G(t)} \}$$

The energy stored in batteries at any hour t is subject to the following constraint:

$$E_{Bmax} \geq E_{B(t)} \geq E_{Bmin}$$

That means that batteries should not be over discharged or overcharged at any time. That protects batteries from being damaged.[2]

4. Feature Of Hybrid System

Hybrid systems can address limitations in terms of fuel flexibility, efficiency, reliability, emissions and / or economics.

Incorporating heat, power, and highly efficient devices (fuel cells, advanced materials, cooling systems, etc.) can increase overall efficiency and conserve energy for a hybrid system when compared with individual technologies.

Achieving higher reliability can be accomplished with redundant technologies and/or energy storage. Some hybrid systems typically include both, which can simultaneously improve the *quality* and *availability* of power.

Hybrid systems can be designed to maximize the use of renewable, resulting in a system with lower emissions than traditional fossil-fueled technologies.

Hybrid systems can be designed to achieve desired attributes at the lowest acceptable cost, which is the key to market acceptance.

5. Wind/PV Hybrid System

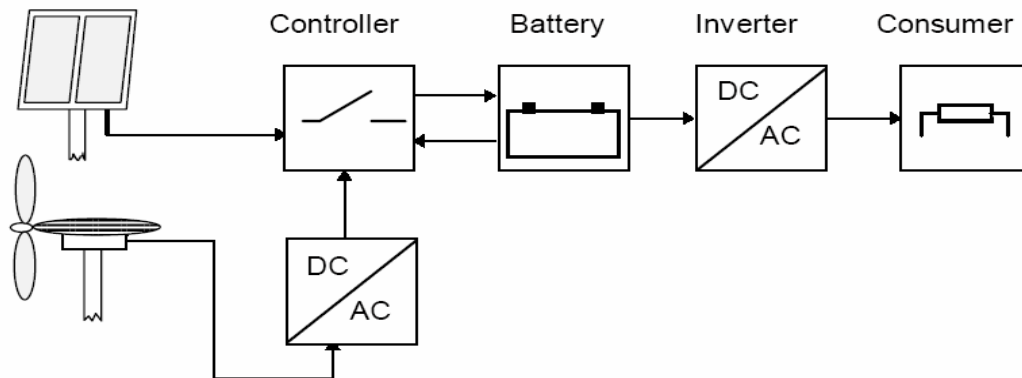

Schematic diagram of a typical hybrid energy system containing solar and wind sources.

A typical hybrid energy system consists of solar and wind energy sources. The principle of an open loop hybrid system of this type is shown in

Figure above. The power produced by the wind generators is an AC voltage but have variable amplitude and frequency that can then be transformed into DC to charge the battery. The controller protects the battery from overcharging or deep discharging. As high voltages can be used to reduce system losses, an inverter is normally introduced to transform the low DC voltage to an AC voltage of 230V of frequency 50 Hz.

The system, whose block diagram is shown in Fig, above, consists of 12 photovoltaic (PV) panels, which can provide a total power of 900 W, and a wind generator that can produce a maximum power of 2200 W. The hybrid PV-wind generator system has been designed to supply continuous power of 1.5 kW and should has the following capabilities:

- Maximizes the electric power produced by the PV panels or by the wind generator by detecting and tracking the point of maximum power.
- Stores the electric energy in lead-acid batteries for a stable repeater operation.
- Controls the charge and discharge processes of the batteries.
- Protects wind generator from over speeding by connecting a dummy load to its output.

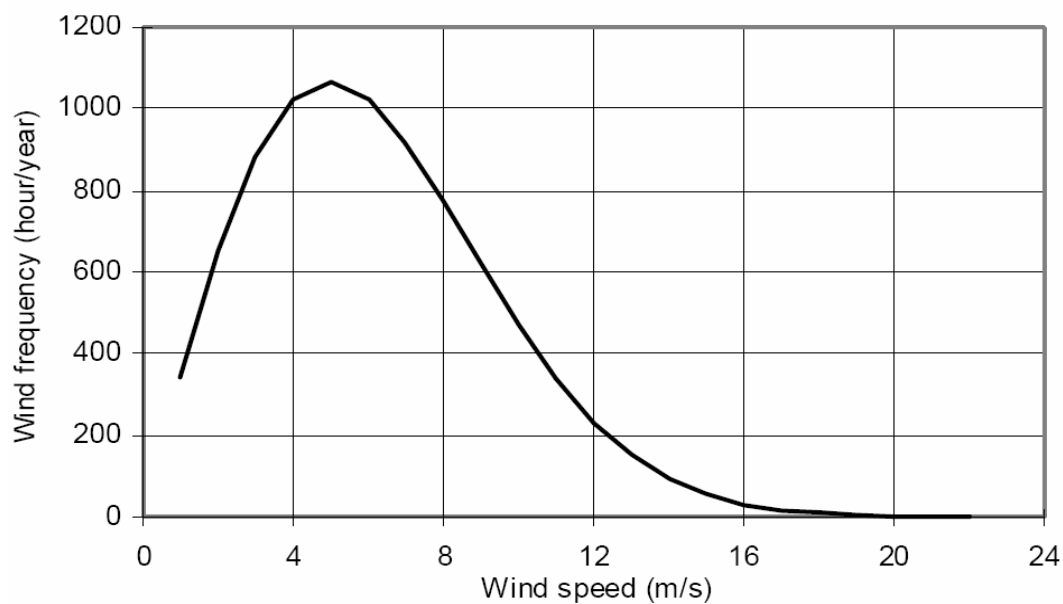

- Initiates the operation of a diesel generator or connects the system to the electric grid (if available), when the renewable energy sources fail to produce sufficient electric energy.

- Provides continuous and uninterruptible electric power (220 V, 50 Hz) to a 1.5-kW house load.[10]

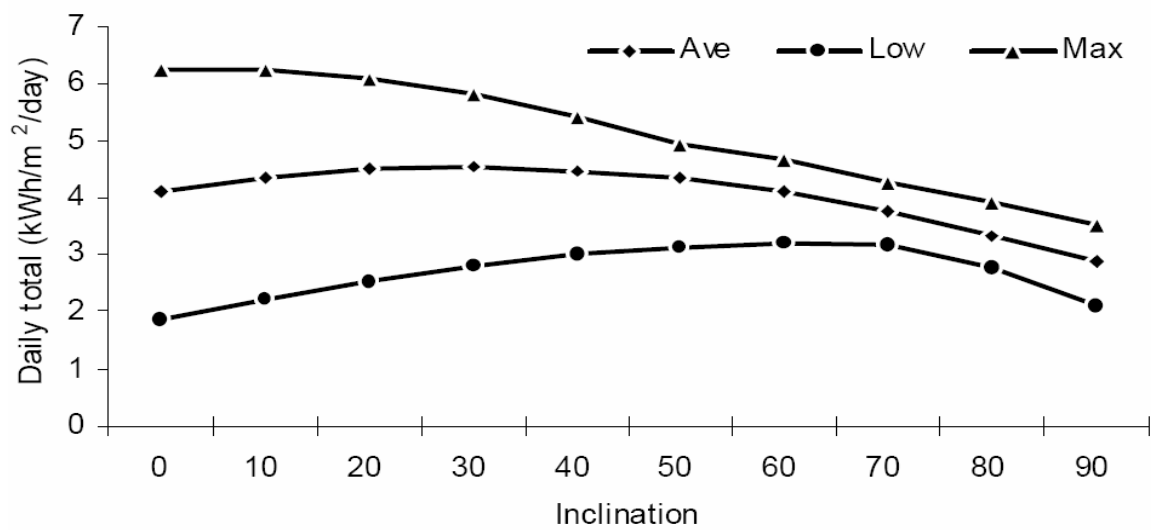

Local solar radiation information: high, low and average values of daily solar radiation calculated over one year

6. PV/Hydro Hybrid System

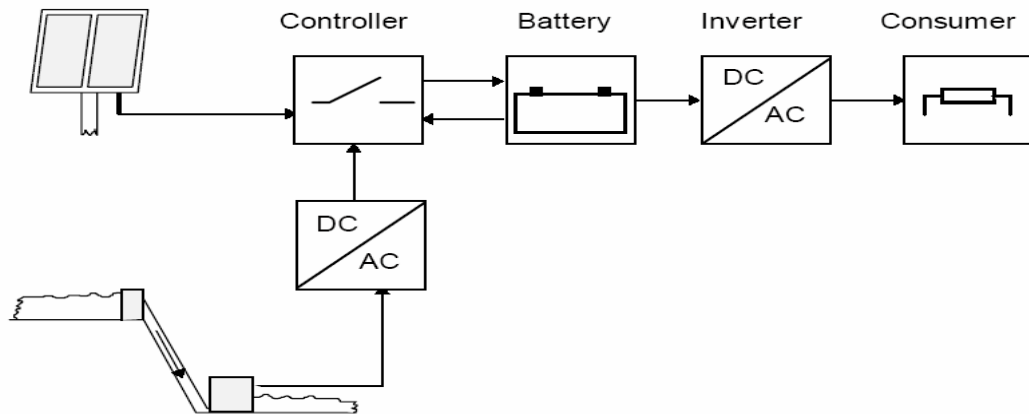

Schematic diagram of a typical hybrid energy system containing solar and hydro sources.

The block diagram of hybrid system, which combines PV with hydro system, is shown above. In this system there is a small reservoir to store the water. This type of hybrid system sometimes depends upon the geographical condition where the water at some height is available. System capacity is depends upon at the water quantity and solar radiation.

The power supplied by falling water is the rate at which it delivers energy, and this depends on the flow rate and water head. The local water flow and head are limited at this project site, and a relatively simple hydro energy component is used in the project. Hydropower available is may be of run off river type hence produces variable amplitude and frequency voltage. It can be use to charge the battery after converting it into DC.

7. Biomass-PV-Diesel Hybrid System

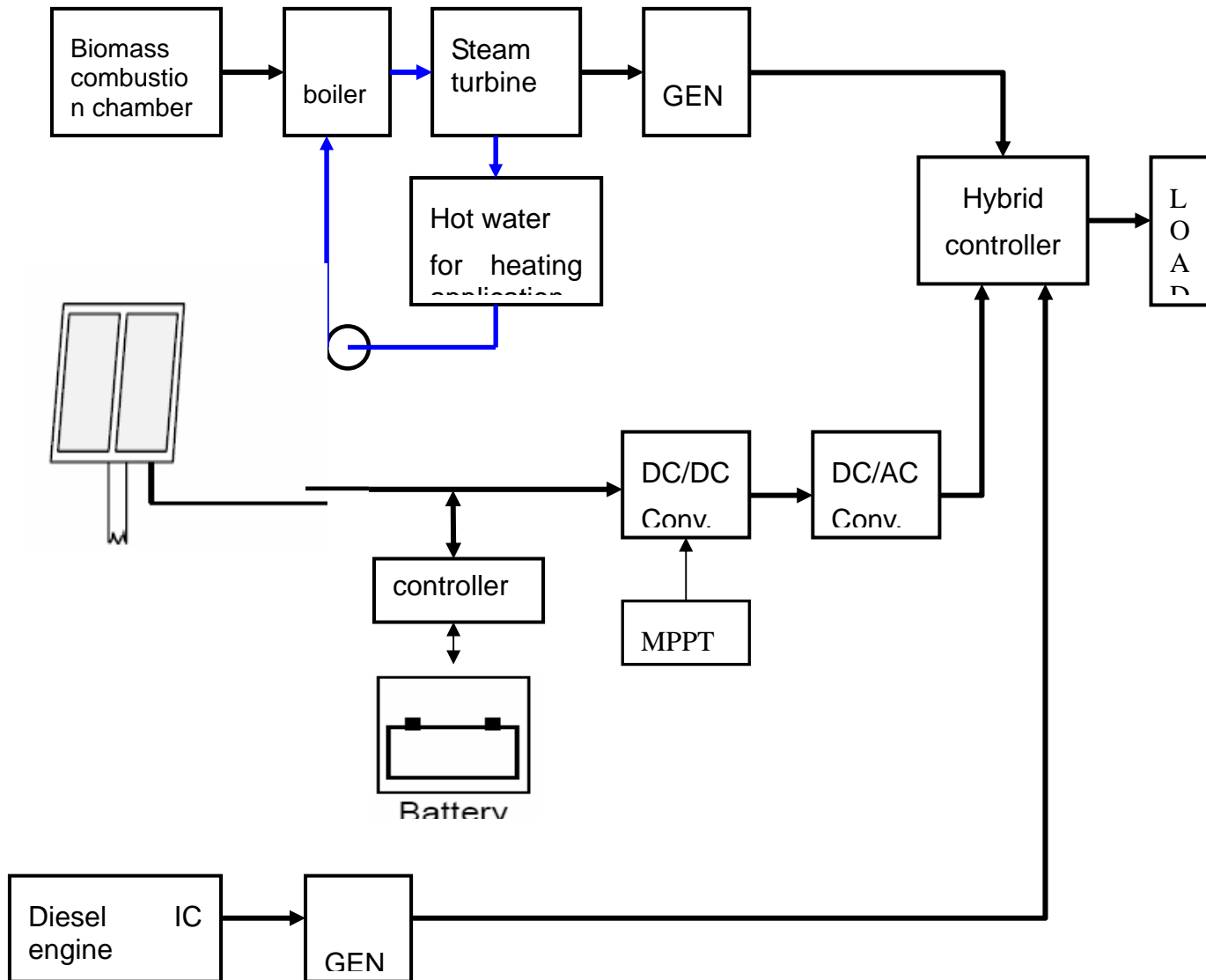

Block diagram of biomass-PV-Diesel Hybrid System

7.1 Biomass Energy:

Biomass is matter usually thought of as garbage. Some of it is just stuff lying around -- dead trees, tree branches, yard clippings, leftover crops, wood chips and bark and sawdust from lumber mills. It can even include used tires and livestock manure [5].

The waste wood, tree branches and other scraps are gathered together in big trucks. The trucks bring the waste from factories and from farms to a biomass power plant. Here the biomass is dumped into huge hoppers. This is then fed into a furnace where it is burned. The heat is used to boil water in the boiler, and the energy in the steam is used to turn turbines and generators. [5].

Other application of Biomass is that it can also be tapped right at the landfill with burning waste products. When garbage decomposes, it gives off methane gas. Pipelines are put into the landfills and the methane gas can be collected. It is then used in power plants to make electricity, or use it for street lighting. This type of biomass is called landfill gas[5].

A similar thing can be done at animal feed lots. In places where lots of animals are raised, the animals - like cattle, cows and even chickens - produce manure. When manure decomposes, it also gives off methane gas similar to garbage. This gas can be burned right at the farm to make energy to run the farm. [5]

7.2 Diesel Energy:

In hybrid system diesel energy is only work as a back up source. When the demand on its peak, so that the available sources are insufficient for that then the diesel back is required.

7.3 Hybrid Controller:

This is a controller, which maintain the energy balance during the load variation. It assigns the priority among the energy sources (means allow one source, which has highest priority, to feed the load if that source is capable and energy coming from other sources will be stored, otherwise allow multiple source to feed the load). It also maintains the synchronizing the voltage signal coming from the different sources. Suppose the instantaneous magnitude of voltage signal coming from PV sources is differ from that of coming from other source say biomass. Hence it causes the local circulating power flow. It can be avoid only by proper synchronizing of signal.

8. PV/Solar thermal/grid-connected hybrid System:

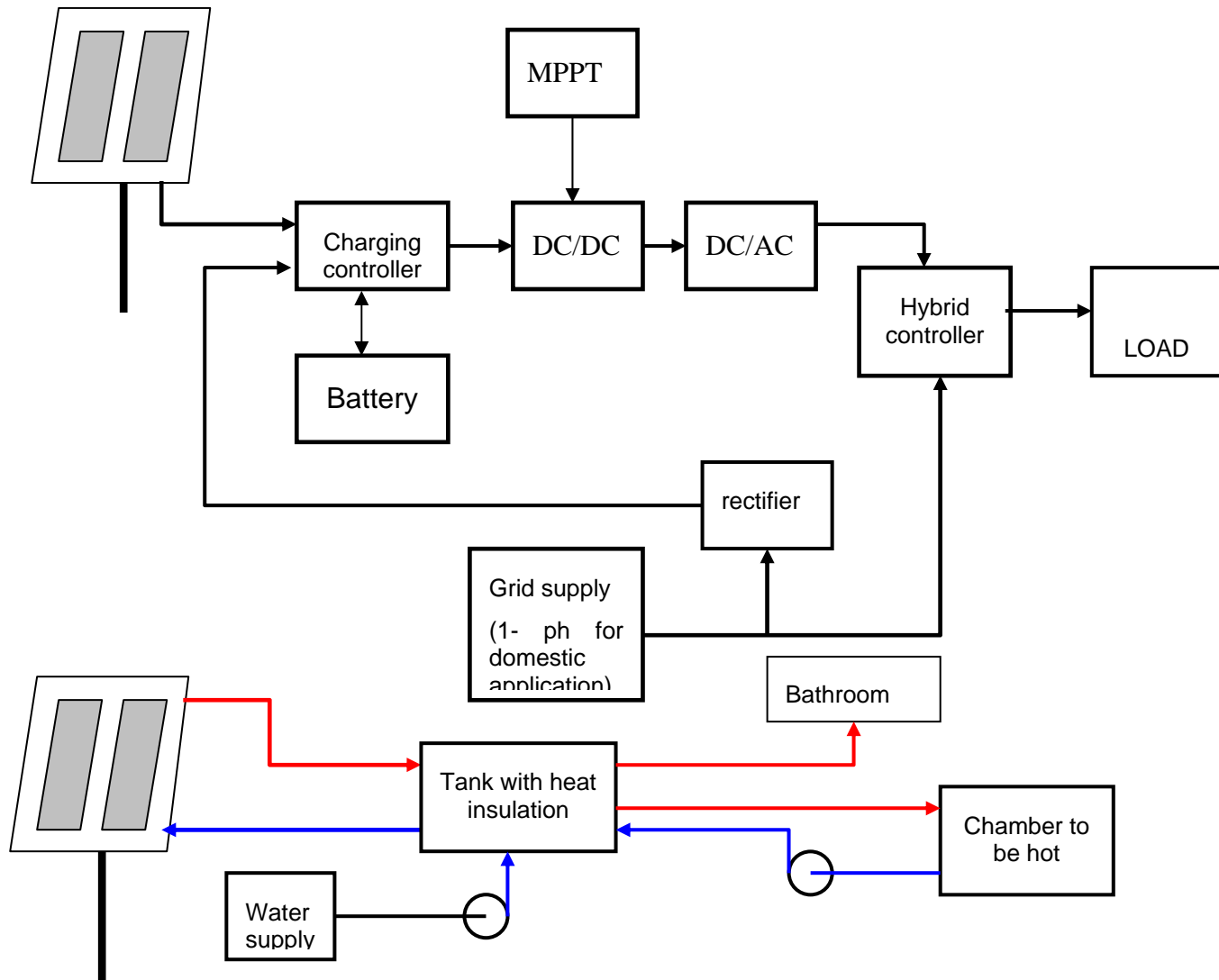

Block diagram of PV-grid connected-solar thermal Hybrid system

— Hot water
 — Cold water

8.1 About Solar Thermal application:

Solar heat is one of the cheapest and most practical forms of renewable energy. Here are few of the most common applications:

8.1.1 Solar Hot Water Heaters:

The sun’s light is an excellent source of hot water for home or commercial use, such as swimming pools, car washes and Laundromats. [9]

8.1.2 Cooking:

Simple solar ovens and cookers are used around the world in both commercial kitchens and in people's homes. Solar cookers can be made with everyday materials such as cardboard and tinfoil. [9]

8.1.3 Home Heating:

Many homes are designed to take advantage of the sun to provide at least part of the heat required over the course of a year. [9]

8.2 PV-Solar Thermal-Grid Hybrid System Description:

In the above hybrid system PV-electric power grid is used as the energy source, for the heating application like hot water for bathing or to heat a room or chamber, solar water heater is used. The hybrid controller is work for synchronizing of the different sources as discussed in sec 7.3 This system are suitable for the places where the solar radiation is available but other sources like wind, wave etc not have good potential and other fusil sources are not economic for generation hence this kind of hybrid system which involving power grid as back-up energy source is good choice.

9. Hybrid System Characteristics

Although hybrid energy systems are open, they can have the characteristics of a closed system if a subsystem with the function of "monitoring" is introduced as a feedback between output (consumer) and input (controller). As inputs of particular hybrid system cannot be changed. However, the load may be changed. With a backup system as another energy source (for example a diesel generator), the system can be designed as a partial closed-loop feedback system.

There are various possibly to make combination of different energy sources. Selection of energy source for hybrid system is mainly depends

upon availability at the place where it going to stabilized. In general in India solar energy is available almost all the places and infrastructure for power generation is rugged hence need low maintenance so it is smart to choose to have PV one of the energy sources in hybrid system. Wave and tidal energy available only at sea shore and need large capital investment and more maintenance, therefore not compatible for household hybrid system. But can be use in large power hybrid system. Corrosion because of seawater is a major drawback. Wind energy source is also a good choice but more preferable for open land hybrid system. And status of wind throughout the year is also important. India has monsoon climate hence has enough potential of wind energy. Biomass energy is good option but it needs regular feeding to continuously operate. Biomass with grid hybrid system is broadly used in sugar mill in India. In residential applications, biomass can be used for space heating or for cooking. Businesses and industry use biomass for several purposes including space heating, hot water heating, and electricity generation. Many industrial facilities, such as lumber mills, naturally produce organic waste. There are still many researches are going on over geothermal energy in India some of the research organization like IREDA working over it. For the system to be more reliable and have low cost, power grid should be involve in the hybrid system

All energy sources have an impact on the environment. Concerns about the greenhouse effect and global warming, air pollution, and energy security have led to increasing interest and more development in renewable energy sources such as solar, wind, geothermal, wave power and hydrogen.

References

1. Bogdan S. Borowy, Ziyad M. Salameh, "Methodology For Optimally Sizing The Combination Of A Battery Bank And PV Array In A Wind/ PV Hybrid System", IEEE transaction on Energy Conversion, Vol. 11, No. 2, June 1996
2. J J Ding, J S Buckeridge, "Design Considerations For A Sustainable Hybrid Energy System" IPENZ Transactions, 2000, Vol. 27, No. 1/EMCh
3. "Report On Utilization Of Hybrid Energy Services In Island And Rural Communities: Indian And European Scenario" prepared by Tata Energy Research Institute (TERI) India.
4. <http://www.energyquest.ca.gov/story/>
5. <http://www.eere.energy.gov/biomass>.
6. <http://solstice.crest.org/renewables/re-kiosk/biomass/applications/index.shtml>
7. http://www.re-energy.ca/t_biomassenergy.shtml
8. http://www.re-energy.ca/t_solarheat.shtml
9. E. Koutroulis, K. Kalaitzakis, N. C. Voulgaris, J. Kaliakatsos, S. Sideris "A Hybrid Pv-Wind Generator System Using A Maximum Power Point Tracking Technique"
10. Chemmangot V. Nayar, Mochamad Ashari, and W.W. Keerthipala, "A Grid-Interactive Photovoltaic Uninterruptible Power Supply System Using Battery Storage And A Back Up Diesel Generator" IEEE transaction on Energy Conversion, Vol. 15, No. 3, sep 2000
11. R. Chedid, Saifur Rahman, "A Decision Support Technique For The Design Of Hybrid Solar-Wind Power Systems" IEEE transaction on Energy Conversion, Vol. 13, No. 1, March 1997

-
12. francois Giraud, Ziyad M. Salameh, **"Steady-State Performance Of A Grid Connected Rooftop Hybrid Wind Photovoltaic Power System With Battery Storage"** IEEE transaction on Energy Conversion, Vol. 16, No. 1, Mar 2001