

2013

Advanced Foundation Engineering

Prof.T.G. Sitharam
Indian Institute of Science, Bangalore



CHAPTER 6: BRACED CUTS

- 6.1 GENERAL CONSIDERATIONS INTRODUCTION
- 6.2 LATERAL EARTH PRESSURE DISTRIBUTION ON BRACED CUTS
 - 6.2.1 Apparent Pressure Diagrams
 - 6.2.2 Deep Cuts in Sand
 - 6.2.3 Cuts in Saturated Clay
 - 6.2.4 Cuts in Stratified Soils
- 6.3 STABILITY OF BRACED CUTS IN SATURATED CLAY
 - 6.3.1 Heaving in Clay Soil
 - Case 1: Formation of Full Plastic Failure Zone Below the Bottom of Cut
 - Case 2: When the formation of Full Plastic Zone is restricted by the presence of hard layer
- 6.4 DESIGN OF VARIOUS COMPONENTS
 - 6.4.1 Struts
 - 6.4.2 Sheet piles
 - 6.4.3 Wales

Chapter 6

Braced Cuts

6.1 Introduction

Shallow excavations can be made without supporting the surrounding material if there is adequate space to establish slopes at which the material can stand. The steepest slopes that can be used in a given locality are best determined by experience. Many building sites extend to the edges of the property lines. Under these circumstances, the sides of the excavation have to be made vertical and must usually be supported by bracings. Common methods of bracing the sides when the depth of excavation does not exceed about 3 m are shown in Figs 6.1(a) and (b). The practice is to drive vertical timber planks known as sheeting along the sides of the excavation. Horizontal beams known as wales are used to keep the sheeting in place. These wales are commonly supported by horizontal struts extending from side to side of the excavation. The struts are usually of timber for widths not exceeding about 2 m. For greater widths metal pipes known as trench braces are commonly used.

When the excavation depth exceeds about 5 to 6 m, the use of vertical timber sheeting will become uneconomical. According to one procedure, steel sheet piles are used around the boundary of the excavation. As the soil is removed from the enclosure, wales and struts are inserted. The wales are commonly of steel and the struts may be of steel or wood. The process continues until the excavation is complete. In most types of soil, it may be possible to eliminate sheet piles and to replace them with a series of H piles spaced 1.5 to 2.5 m apart. The H piles, known as soldier piles or soldier beams, are driven with their flanges parallel to the sides of the excavation as shown in Fig. 6.1(b). As the soil next to the piles is removed horizontal boards known as lagging are introduced as shown in the figure and are wedged against the soil outside the cut. As the general depth of excavation advances from one level to another, wales and struts are inserted in the same manner as for steel sheeting. If the width of a deep excavation is too great to permit economical use of struts across the entire excavation, tiebacks are often used as an alternative to cross-bracings as shown in Fig. 6.1(c). Inclined holes are drilled into the soil outside the sheeting or H piles.

Tensile reinforcement is then inserted and concreted into the hole. Each tieback is usually prestressed before the depth of excavation is increased.

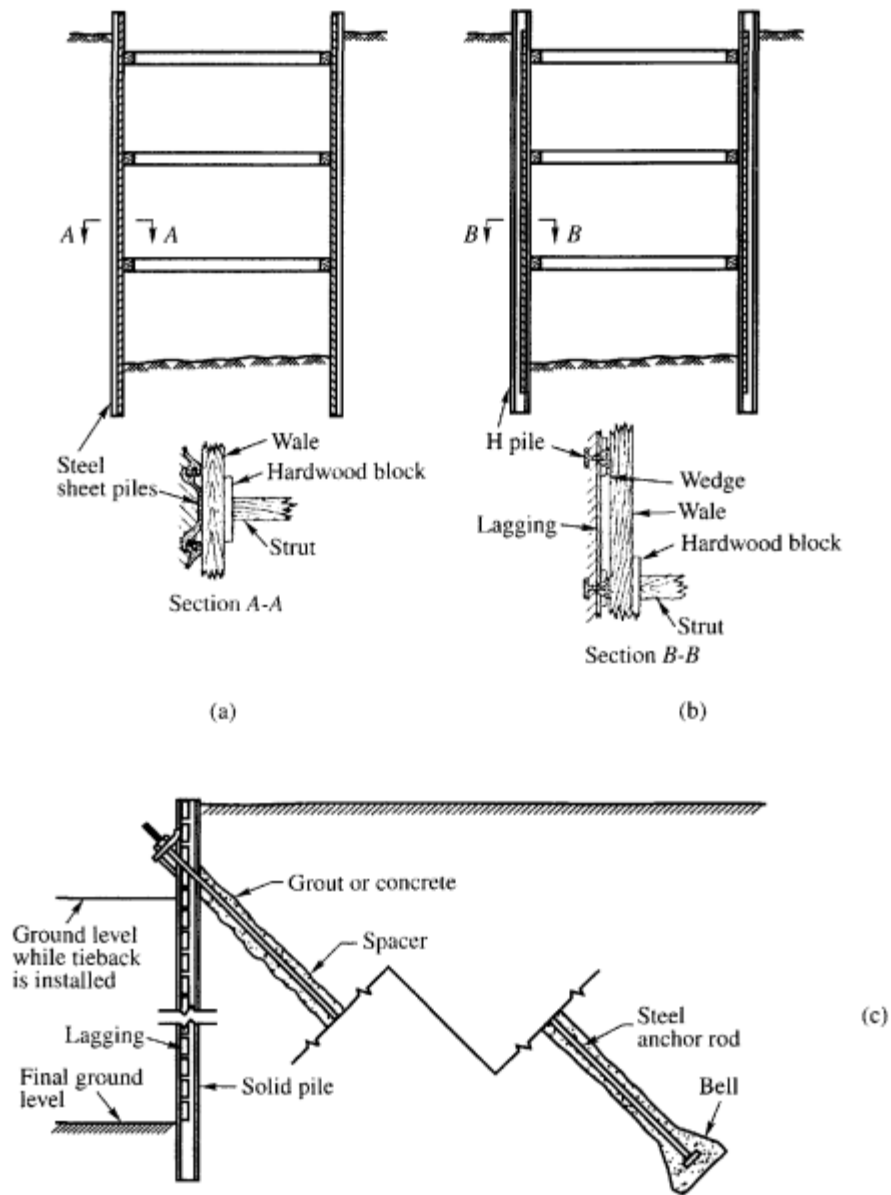

Fig. 6.1: Cross sections through typical bracing in deep excavation, (a) sides retained by steel sheet piles, (b) sides retained by H piles & lagging, (c) one of the several tieback systems for supporting vertical sides of open cut, several sets of anchors may be used at different elevations (Peck, 1969)

6.2 Lateral Earth Pressure Distribution on Braced-Cuts

Since most open cuts are excavated in stages within the boundaries of sheet pile walls or walls consisting of soldier piles and lagging, and since struts are inserted progressively as the excavation proceeds, the walls are likely to deform as shown in Fig. 6.2. Little inward movement can occur at the top of the cut after the first strut is inserted. The pattern of deformation differs so greatly from that required for Rankine's state that the distribution of earth pressure associated with retaining walls is not a satisfactory basis for design (Peck et al, 1974). The pressures against the upper portion of the walls are substantially greater than those indicated by the equation.

$$P_a = \frac{1 - \sin\phi}{1 + \sin\phi} P_v$$

for Rankine's condition

where, P_v = vertical pressure, ϕ = friction angle

6.2.1 Apparent Pressure Diagrams

Peck (1969) presented pressure distribution diagrams on braced cuts. These diagrams are based on a wealth of information collected by actual measurements in the field. Peck called these pressure diagrams apparent pressure envelopes which represent fictitious pressure distributions for estimating strut loads in a system of loading. Figure 6.3 gives the apparent pressure distribution diagrams as proposed by Peck.

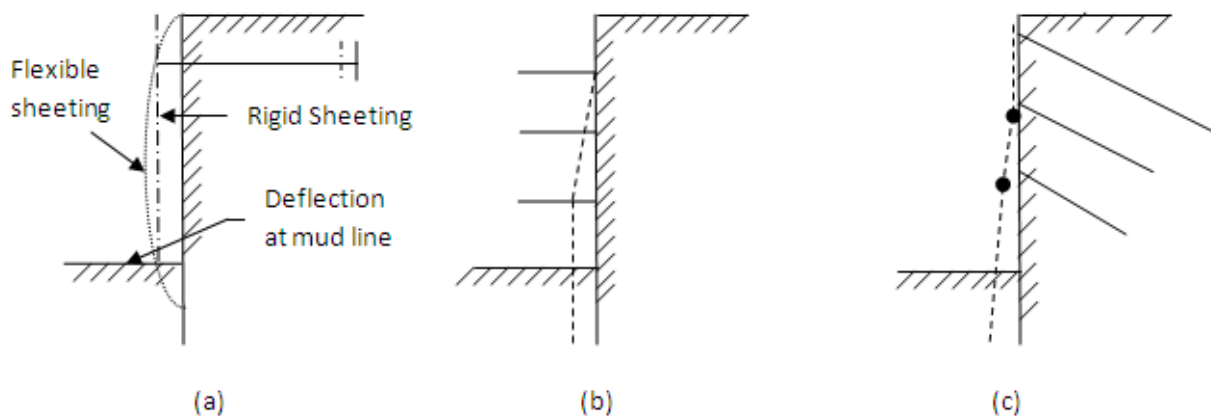

Fig. 6.2: Typical pattern of deformation of vertical walls (a) anchored bulkhead, (b) braced cut, (c) tieback cut (Peck et al., 1974)

6.2.2 Deep Cuts in Sand

The apparent pressure diagram for sand given in Fig. 6.3 was developed by Peck (1969) after a great deal of study of actual pressure measurements on braced cuts used for subways. The pressure diagram given in Fig. 6.3 (b) is applicable to both loose and dense sands. The struts are to be designed based on this apparent pressure distribution. The most probable value of any individual strut load is about 25 percent lower than the maximum (Peck, 1969). It may be noted here that this apparent pressure distribution diagram is based on the assumption that the water table is below the bottom of the cut.

The pressure p_a is uniform with respect to depth. The expression for p_a is

$$p_a = 0.65\gamma HK_A$$

where, $K_A = \tan^2 (45 - \phi/2)$ and $\gamma =$ unit weight of sand

6.2.3 Cuts in Saturated Clay

Peck (1969) developed two apparent pressure diagrams, one for soft to medium clay and the other for stiff fissured clay. He classified these clays on the basis of non-dimensional factors

Stiff Fissured clay

$$N_s = \frac{\gamma H}{c} \leq 4$$

Soft to Medium clay

$$N_s = \frac{\gamma H}{c} > 4$$

where, $\gamma =$ unit weight of clay, $c =$ undrained cohesion ($\phi = 0$)

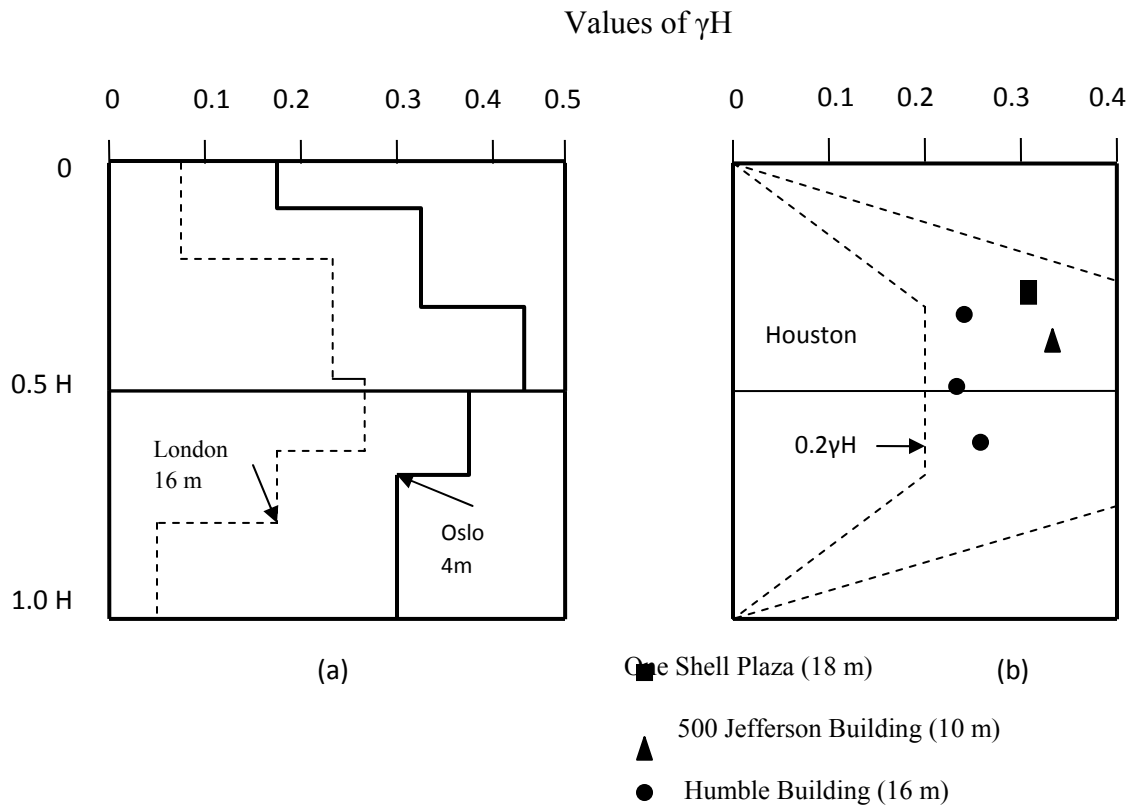

Fig. 6.4: Maximum apparent pressures for cuts in stiff clays: (a) fissured clays in London & Oslo, (b) stiff slicken sided clays in Houston (Peck, 1969)

6.2.4 Cuts in Stratified Soils

It is very rare to find uniform deposits of sand or clay to a great depth. Many times layers of sand and clays overlying one another are found in nature. Even the simplest of these conditions does not lend itself to rigorous calculations of lateral earth pressures by any of the methods available. Based on field experience, empirical or semi-empirical procedures for estimating apparent pressure diagrams may be justified. Peck (1969) proposed the following unit pressure for excavations in layered soils (sand and clay) with sand overlying as shown in Fig. 6.5.

When layers of sand and soft clay are encountered, the pressure distribution shown in Fig. 6.3(d) may be used if the unconfined compressive strength ' q ' is substituted by the average \bar{q}_u and the unit weight of soil γ by the average $\bar{\gamma}$ (Peck, 1969). The expressions for \bar{q}_u and $\bar{\gamma}$ are;

$$\bar{q}_u = \frac{1}{H}(\gamma_1 K_s h_1^2 \tan \phi + h_2 \eta q_u) \quad (\text{Eq.6.1})$$

$$\bar{\gamma} = \frac{1}{H}(\gamma_1 h_1 + \gamma_2 h_2) \quad (\text{Eq.6.2})$$

where, H= total depth of excavation

γ_1, γ_2 = Unit weights of sand and clay respectively

h_1, h_2 = thickness of sand and clay layers respectively

K_s = hydrostatic pressure ratio for the sand layer, may be taken as equal to 1.0 for design purposes

ϕ = angle of friction of sand

η = coefficient of progressive failure which varies from 0.5 to 1.0 depending upon the creep characteristics of clay. For Chicago clay it varies from 0.75 to 1.0, q_u = unconfined compressive strength of clay.

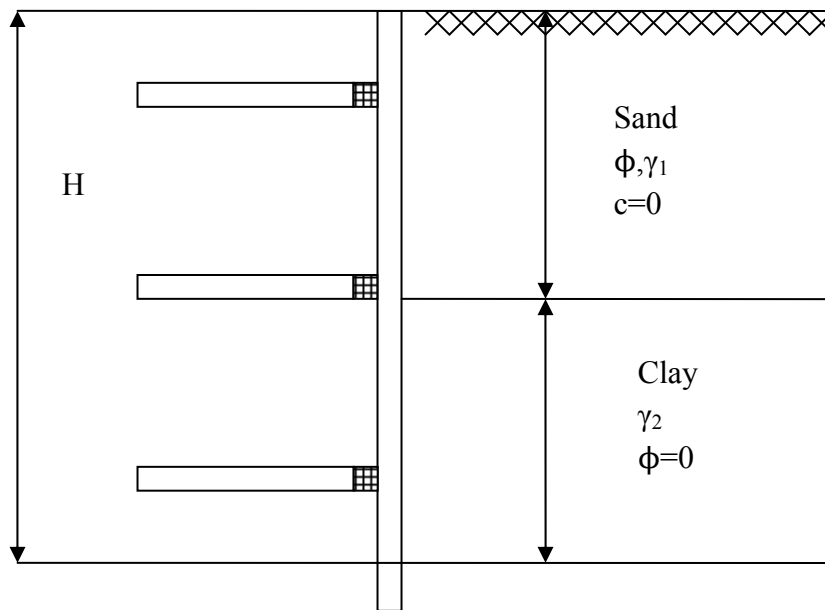

Fig. 6.5: Cuts in stratified soil

6.3 Stability of Braced Cuts in Saturated Clay

A braced-cut may fail as a unit due to unbalanced external forces or heaving at the bottom of the excavation. If the external forces acting on opposite sides of the braced cut are unequal, the stability of the entire system has to be analyzed. If soil on one side of a braced cut is removed due to some unnatural forces the stability of the system will be impaired. However, we are concerned here about the stability of the bottom of the cut. The two cases that may arise are;

1. Heaving in clay soil
2. Heaving in cohesionless soil

6.3.1 Heaving in Clay Soil

The danger of heaving is greater if the bottom of the cut is soft clay. Even in a soft clay bottom, two types of failure are possible. They are;

Case 1: When the clay below the cut is homogeneous at least up to a depth equal $0.7 B$ where B is the width of the cut.

Case 2: When a hard stratum is met within a depth equal to $0.7 B$.

In the first case a full plastic failure zone will be formed and in the second case this is restricted as shown in Fig. 6.6. A factor of safety of 1.5 is recommended for determining the resistance here. Sheet piling is to be driven deeper to increase the factor of safety. The stability analysis of the bottom of the cut as developed by Terzaghi (1943) is as follows.

Case 1) Formation of Full Plastic Failure Zone Below the Bottom of Cut

Figure 6.6 (a) is a vertical section through a long cut of width B and depth H in saturated cohesive soil ($\phi=0$). The soil below the bottom of the cut is uniform up to a considerable depth for the formation of a full plastic failure zone. The undrained cohesive strength of soil is c . The weight of the blocks of clay on either side of the cut tends to displace the underlying clay toward the excavation. If the underlying clay experiences a bearing capacity failure, the bottom of the excavation heaves and the earth pressure against the bracing increases considerably. The anchorage load block of soil $a b c d$ in Fig. 6.6 (a) of width \bar{B} (assumed) at the level of the bottom of the cut per unit length may be expressed as;

$$Q = \gamma H \bar{B} - cH = \bar{B}H \left(\gamma - \frac{c}{\bar{B}} \right) \quad (\text{Eq.6.3})$$

The vertical pressure q per unit length of a horizontal, 'ba', is

$$q = \frac{Q}{\bar{B}} = H \left(\gamma - \frac{c}{\bar{B}} \right) \quad (\text{Eq.6.4})$$

The bearing capacity q_u per unit area at level ab is

$$q_u = N_c * c = 5.7c, \text{ where } N_c = 5.7$$

The factor of safety against heaving is

$$F_s = \frac{q_u}{q} = \frac{5.7c}{H \left(\gamma - \frac{c}{\bar{B}} \right)} \quad (\text{Eq.6.5})$$

Because of the geometrical condition, it has been found out that the width \bar{B} cannot exceed $0.7B$. Substituting the value for \bar{B} ,

$$F_s = \frac{5.7c}{H \left(\gamma - \frac{c}{0.7B} \right)} \quad (\text{Eq.6.6})$$

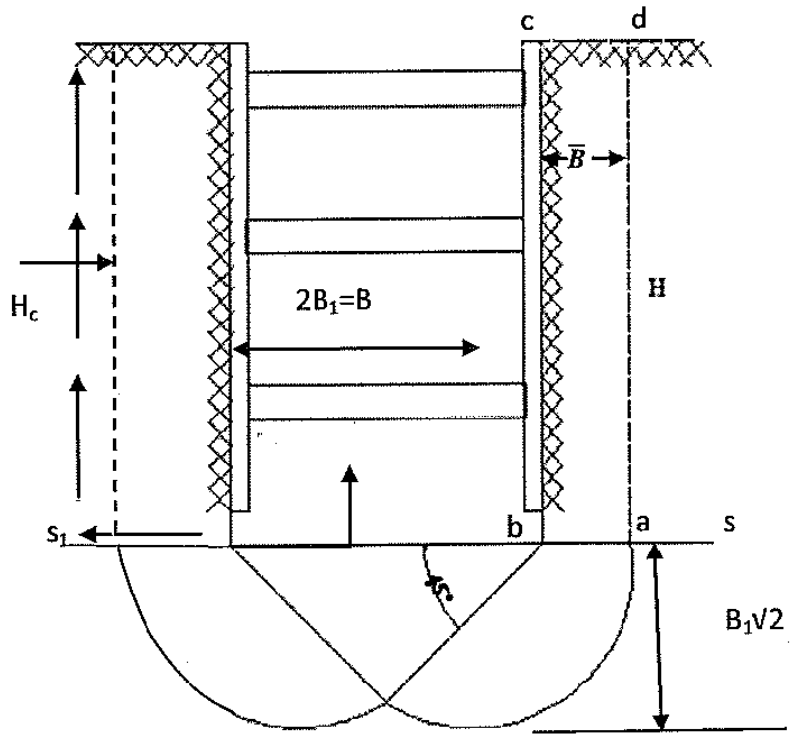

(a)

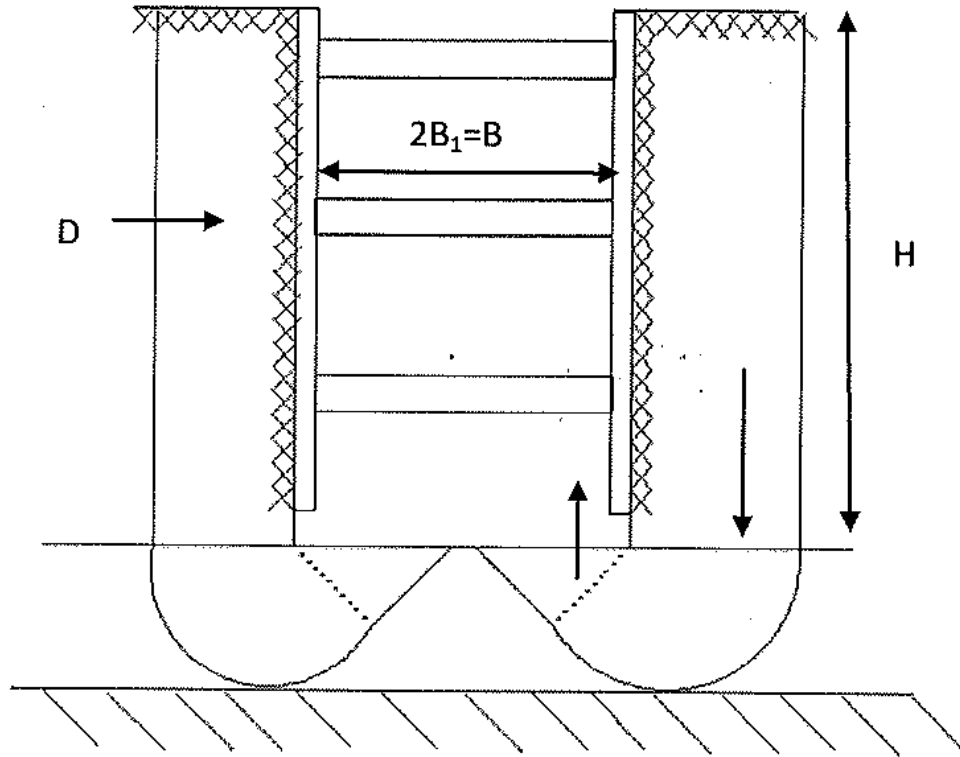

(b) Hard Stratum

Fig. 6.6: Stability of braced cut: (a) heave of bottom of timbered cut in soft clay if no hard stratum interferes with flow of clay, (b) As before, if clay rests at shallow depth below bottom of cut on hard stratum (after Terzaghi, 1943)

Case 2) When the formation of Full Plastic Zone is restricted by the presence of hard layer

If a hard layer is located at a depth D below the bottom of the cut (which is less than $0.7B$), the failure of the bottom occurs as shown in Fig. 6.6(b). The width of the strip which can sink is also equal to D . Replacing $0.7B$ by D in Eq.6.5 the factor of safety is represented by;

$$F_s = \frac{5.7c_u}{H\left(\gamma - \frac{c}{D}\right)} \quad (\text{Eq.6.7})$$

For a cut in soft clay with a constant value C_u below the bottom of the cut, 'D' in the above equation becomes large, and F_s approach the value;

$$F_s = 5.7c_u / \gamma H = 5.7/N_s$$

where, $N_s = \gamma H / c_u$

N_s is termed the stability number. The stability number is a useful indicator of potential soil movements. The soil movement is smaller for smaller values of N_s . The analysis discussed so far is for long cuts. For short cuts, square, circular or rectangular, the factor of safety against heave can be found in the same way as for footings.

6.4 Design of Various Components

6.4.1 Struts

In construction work, struts should have a minimum vertical spacing of about 2.75 m (9 ft) or more. Struts are horizontal columns subject to bending. The load-carrying capacity of columns depends on their slenderness ratio, which can be reduced by providing vertical and horizontal supports at intermediate points. For local width splicing the struts may be necessary. For braced cuts in clayey soils, the depth of the first strut below the ground surface should be less than the depth of tensile crack Z_c , obtained from Eq.6.8.

$$\sigma_a' = \gamma Z K_A - 2c' \sqrt{K_A} \quad (\text{Eq.6.8})$$

where, K_A = Rankine's coefficient of active earth pressure.

To find Z_c , we equate $\sigma_a' = 0$,

$$\text{So, } \gamma Z_c K_A = 2c' \sqrt{K_A}$$

$$Z_c = \frac{2c'}{\gamma \sqrt{K_A}}$$

$$\text{With } \phi=0, K_A=1, Z_c = \frac{2c}{\gamma}$$

A simplified conservative procedure may be used to determine the strut loads. Although this procedure will vary, depending on the engineers involved in the project, the following is a step-by-step outline of the general methodology (see Figure 6.7):

Step 1:-Draw the pressure envelope for the braced cut. Also, show the proposed strut levels. Figure 6.7a shows a pressure envelope for a sandy soil: however, it could also be for clay. The strut levels are marked A, B, C and D. The sheet piles (or soldier beams) are assumed to be hinged at the strut levels, except for the top and bottom ones. In Figure 6.7a the hinges are at the level of struts Band C'. (Many designers also assume the sheet piles or soldier beams to be hinged at all strut-levels except for the top.)

Step 2:-Determine the reactions for the two simple cantilever beams (top and bottom) and all the beams in-between. In Figure 6.7b, these reactions are A, B₁, B₂, C₁, C₂and D.

Step 3:-The strut loads in the figure may be calculated via the formula

$$P_A = (A) (s)$$

$$P_B = (B_1+B_2) (s)$$

$$P_C = (C_1+C_2) (s)$$

$$P_D = (D) (s)$$

where

P_A, P_B, P_C& P_D= loads to be taken by the individual struts at levels A, B, C, and D, respectively

A, B₁, B₂, C₁, C₂, D= reactions calculated in Step 2 (note the unit force/unit length of the braced cut)

s = horizontal spacing of the struts (see plan in Figure 6.7a)

Step 4:- Knowing the strut loads at each level and the intermediate bracing conditions allows selection or the proper sections from the steel construction manual

6.4.2Sheet piles

The following steps are involved in designing the sheet piles:

Step I:-For each of the sections shown in Figure 6.7b, determine the max bending moment.

Step II:-Select the maximum value of the maximum bending moments (M_{\max}) obtained in Step 1. Note that the unit of this moment will be, for example, kN-m/m length of the wall.

Step III:-Calculate the required section modulus of the sheet piles, namely,

$$S = \frac{M_{\max}}{\sigma_{all}} \quad (\text{Eq.6.9})$$

where, σ_{all} = allowable flexural stress of the sheet pile material.

Step IV:- Choose a sheet pile having a section modulus greater than or equal to the required section modulus (Types of steel sections vary with different countries. Commonly used sections in some Asian countries are H, I, U, Z and Line sections. Various types of sections with properties are given in steel codes of respective countries).

6.4.3Wales

Wales may be treated as continuous horizontal members if they are spliced properly. Conservatively, they may also be treated as though they are pinned at the struts. For the section shown in figure 6.7a, the maximum moments for the wales (assuming that they are pinned at the struts) are,

$$\text{At level A, } M_{\max} = \frac{As^2}{8}$$

$$\text{At level B, } M_{\max} = \frac{(B_1 + B_2)s^2}{8}$$

$$\text{At level C, } M_{\max} = \frac{(C_1 + C_2)s^2}{8}$$

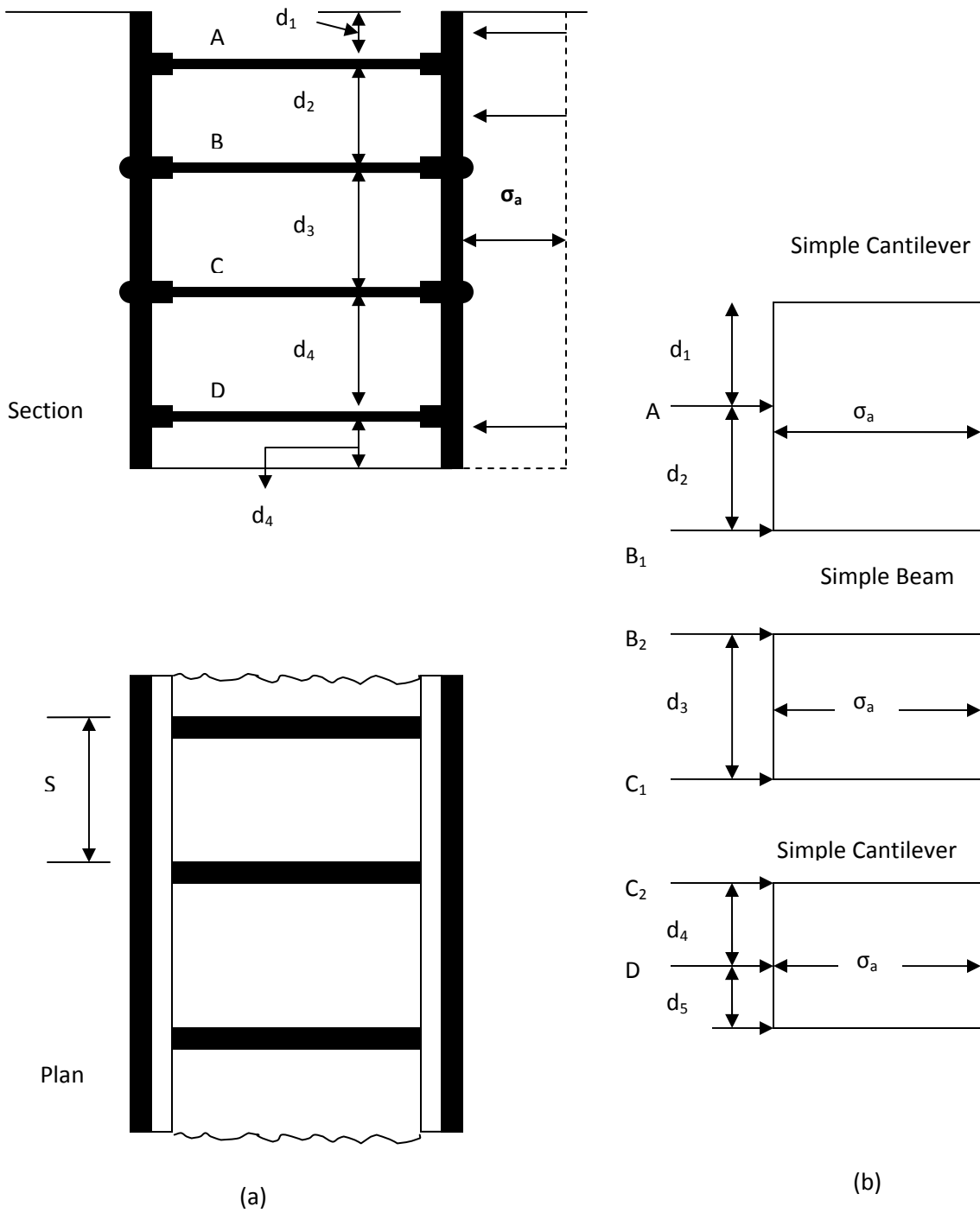

Fig.6.7 Determination of strut loads: a) section & plan of the cut, b) method for determining strut loads

$$\text{At level D, } M_{\max} = \frac{Ds^2}{8}$$

where A, B₁, B₂, C₁, C₂ and D are the reactions under the struts per unit length of pile (see Step 2 of strut design).

Now determine the section modulus of the wales:

$$S = \frac{M_{\max}}{\sigma_{all}}$$

The wales are sometimes fastened to the sheet piles at points that satisfy the lateral pressure requirements.